

** MILLING TO BE PAID FOR AS INCIDENTAL MILLING

PAVEMENT TIE-IN DETAIL

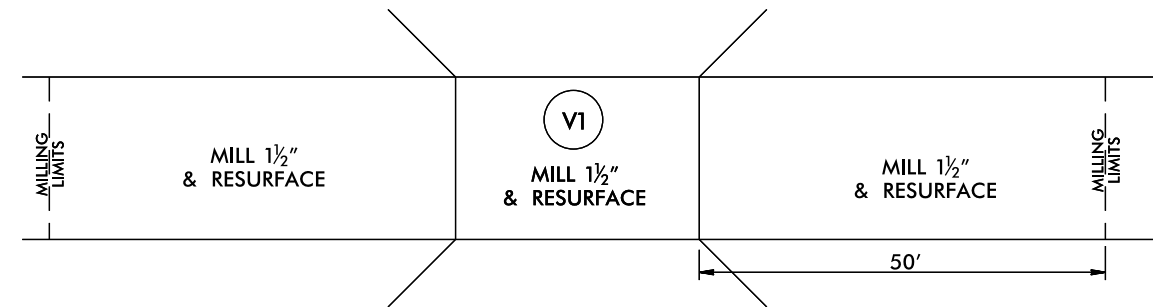

BRIDGE DRAWING FOR MAP NO 1 US 74 BUS BRIDGE #1

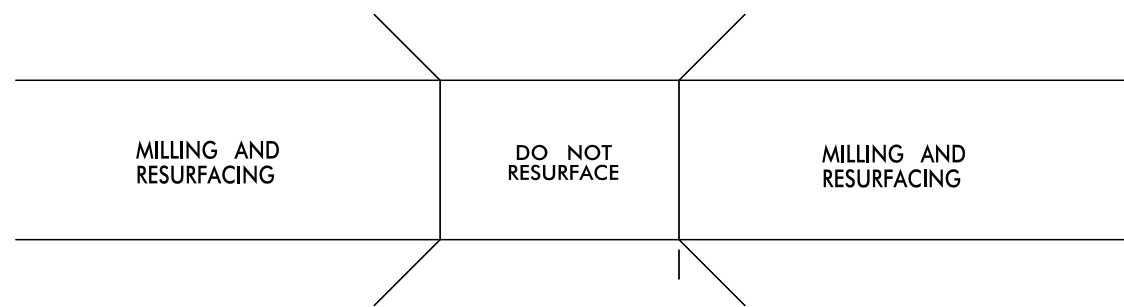

BRIDGE DRAWING FOR MAP NO 3 US 1 BRIDGE #29

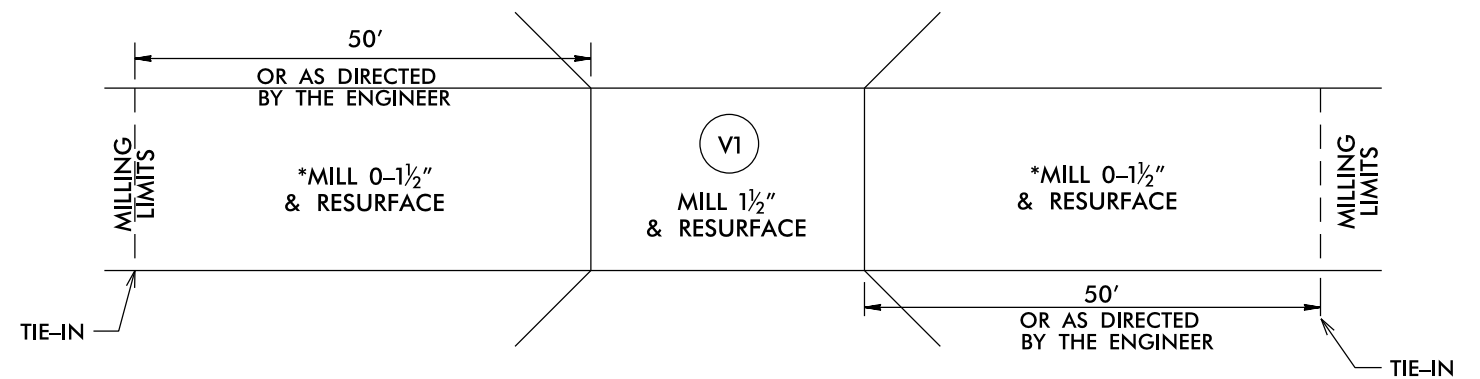

BRIDGE DRAWING FOR MAP NO 16 SR 1150 GREEN RD BRIDGE #105

* MILLING FOR APPROACHES SHALL BE PAID FOR UNDER INCIDENTAL MILLING