

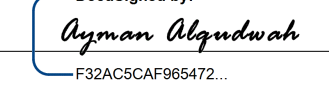

TIP NO. U-5606	SHEET NO. PMP-1
APPROVED:  <small>—PROF. 028387—</small>	
DATE: Nov 30, 2021	
SEAL 	
DOCUMENT NOT CONSIDERED FINAL UNLESS ALL SIGNATURES COMPLETED	

**STATE OF NORTH CAROLINA
DEPARTMENT OF TRANSPORTATION**

**PAVEMENT MARKING PLAN
PITT COUNTY**

**LOCATION: SR 1598 /1620 (DICKINSON AVE) – FROM NC-11 (MEMORIAL DR)
TO SR 1610 (READE CIRCLE)**

- UPDATED PAVEMENT MARKING SCHEDULE
11/29/21
D. BEARD

T.I.P.: U-5606

CONTRACT: C204070

**U-5606 PAVEMENT
MARKING SCHEDULE**

SYMBOL	DESCRIPTION
<u>(FINAL PAVEMENT MARKINGS)</u>	
	<u>THERMOPLASTIC (16", 90 MILS)</u>
T1	WHITE LINE RR X
	<u>THERMOPLASTIC (24", 90 MILS)</u>
T2	WHITE STOPBAR
T3	WHITE CROSSWALK LINE
	<u>THERMOPLASTIC (4", 90 MILS)</u>
T8	2 FT.-6 FT./SP WHITE MINISKIP
TC	10 FT. WHITE SKIP
TB	YELLOW EDGELINE
TD	3 FT.-9 FT./SP WHITE MINISKIP
TE	WHITE SOLID LANE LINE
TF	10 FT. YELLOW SKIP
TI	YELLOW DOUBLE CENTER
TH	YELLOW SINGLE CENTER
	<u>THERMOPLASTIC (8", 90 MILS)</u>
TO	WHITE DIAGONAL
TN	WHITE GORE LINE
TQ	WHITE CROSSWALK LINE
	<u>THERMOPLASTIC (12", 90 MILS)</u>
TT	WHITE CROSSWALK LINE
	<u>THERMOPLASTIC PAVEMENT MARKING SYMBOLS (90 MILS)</u>
UA	LEFT TURN ARROW
UB	RIGHT TURN ARROW
UC	STRAIGHT ARROW
UE	COMBO STRAIGHT / RIGHT ARROW
UI	ALPHANUMERIC CHARACTER
UN	24" YIELD LINE TRIANGLE

GENERAL NOTES

- THE FOLLOWING GENERAL NOTES APPLY AT ALL TIMES FOR THE DURATION OF THE CONSTRUCTION PROJECT, EXCEPT WHEN OTHERWISE NOTED IN THE PLAN, OR DIRECTED BY THE ENGINEER.
- A) INSTALL PAVEMENT MARKINGS AND PAVEMENT MARKERS ON THE FINAL SURFACE AS FOLLOWS:

ROAD NAME	MARKING	MARKER
DICKINSON AVE.	THERMOPLASTIC	NONE
ALL -Y- LINES	THERMOPLASTIC	NONE
 - B) TIE PROPOSED PAVEMENT MARKING LINES TO EXISTING PAVEMENT MARKING LINES.
 - C) REMOVE/REPLACE ANY CONFLICTING/DAMAGED PAVEMENT MARKINGS AND MARKERS.
 - D) PASSING ZONES WILL BE DETERMINED IN THE FIELD AND MUST BE APPROVED BY THE ENGINEER.
 - E) STOP BAR LOCATION AT NON-SIGNALIZED INTERSECTIONS MAY BE ADJUSTED AS DIRECTED BY THE ENGINEER.
 - F) UNLESS OTHERWISE SPECIFIED, HEATED-IN-PLACE THERMOPLASTIC MAY BE USED IN LIEU OF EXTRUDED THERMOPLASTIC FOR STOP BARS, SYMBOLS, CHARACTERS AND DIAGONALS. IF HEATED-IN-PLACE IS USED, IT SHALL BE PAID FOR USING THE EXTRUDED THERMOPLASTIC PAY ITEM.
 - G) DUE TO THE COMPLEX NATURE OF THE SIDEWALKS AND STREETScape PLANS, THE CURB RAMPS ARE SHOWN AS A GUIDE. REFER TO THE STREETScape AND ALTERNATE CURB RAMP DESIGNS IN THE PLANS.

ROADWAY STANDARD DRAWING

THE FOLLOWING ROADWAY STANDARDS AS APPEAR IN "ROADWAY STANDARD DRAWINGS" - PROJECT SERVICES UNIT - N.C. DEPARTMENT OF TRANSPORTATION - RALEIGH, N.C., DATED JANUARY 2018 ARE APPLICABLE TO THIS PROJECT AND BY REFERENCE HEREBY ARE CONSIDERED A PART OF THESE PLANS:

STD. NO.	TITLE
1205.01	PAVEMENT MARKINGS - LINE TYPES AND OFFSETS
1205.02	PAVEMENT MARKINGS - TWO-LANE AND MULTILANE ROADWAYS
1205.04	PAVEMENT MARKINGS - INTERSECTIONS
1205.05	PAVEMENT MARKINGS - TURN LANES
1205.07	PAVEMENT MARKINGS - PEDESTRIAN CROSSWALKS
1205.08	PAVEMENT MARKINGS - SYMBOLS AND WORD MESSAGES
1205.09	PAVEMENT MARKINGS - PAINTED ISLANDS
1205.11	PAVEMENT MARKINGS - RAILROAD CROSSINGS

PLAN PREPARED BY: N.C.D.O.T. SIGNING AND DELINEATION UNIT	
<u>AYMAN ALQUDWAH, PE, CPM</u>	SIGNING & DELINEATION REGIONAL ENGINEER
<u>ERIC WARD</u>	SIGNING & DELINEATION PROJECT DESIGN ENGINEER

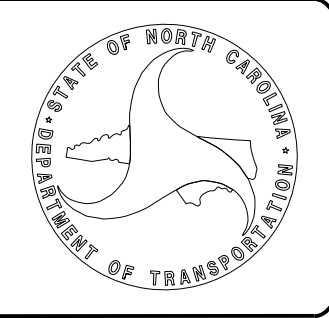

INDEX

SHEET NO.	DESCRIPTION
PMP-1	PAVEMENT MARKING PLAN TITLE, STANDARDS, NOTES AND SCHEDULE SHEET
PMP-2-10	PAVEMENT MARKING DETAIL

I:\30\21\TIP\Projects-U\U5606\Traffic\Signing\CADD\PM\U-5606-PMP-1-22-29-21-REV.dgn
 User: dbeard

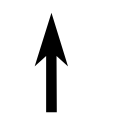
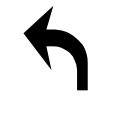
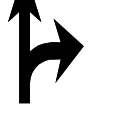
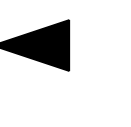
SYMBOL LEGEND	
	UC STRAIGHT ARROW
	UA LEFT ARROW
	UE COMBO RIGHT/ STRAIGHT ARROW
	UN 24" YIELD LINE TRIANGLE

** DUE TO THE COMPLEX NATURE OF THE SIDEWALKS AND STREETSCAPE PLANS,
THE CURB RAMP ARE SHOWN AS A GUIDE. REFER TO THE STREETSCAPE
AND ALTERNATE CURB RAMP DESIGNS IN THE PLANS.

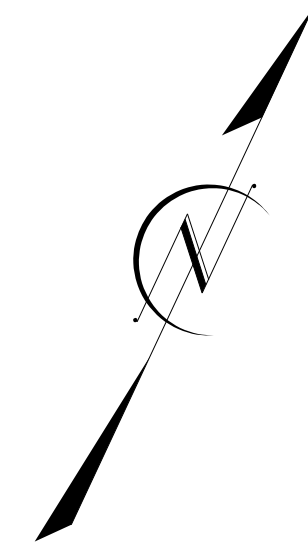



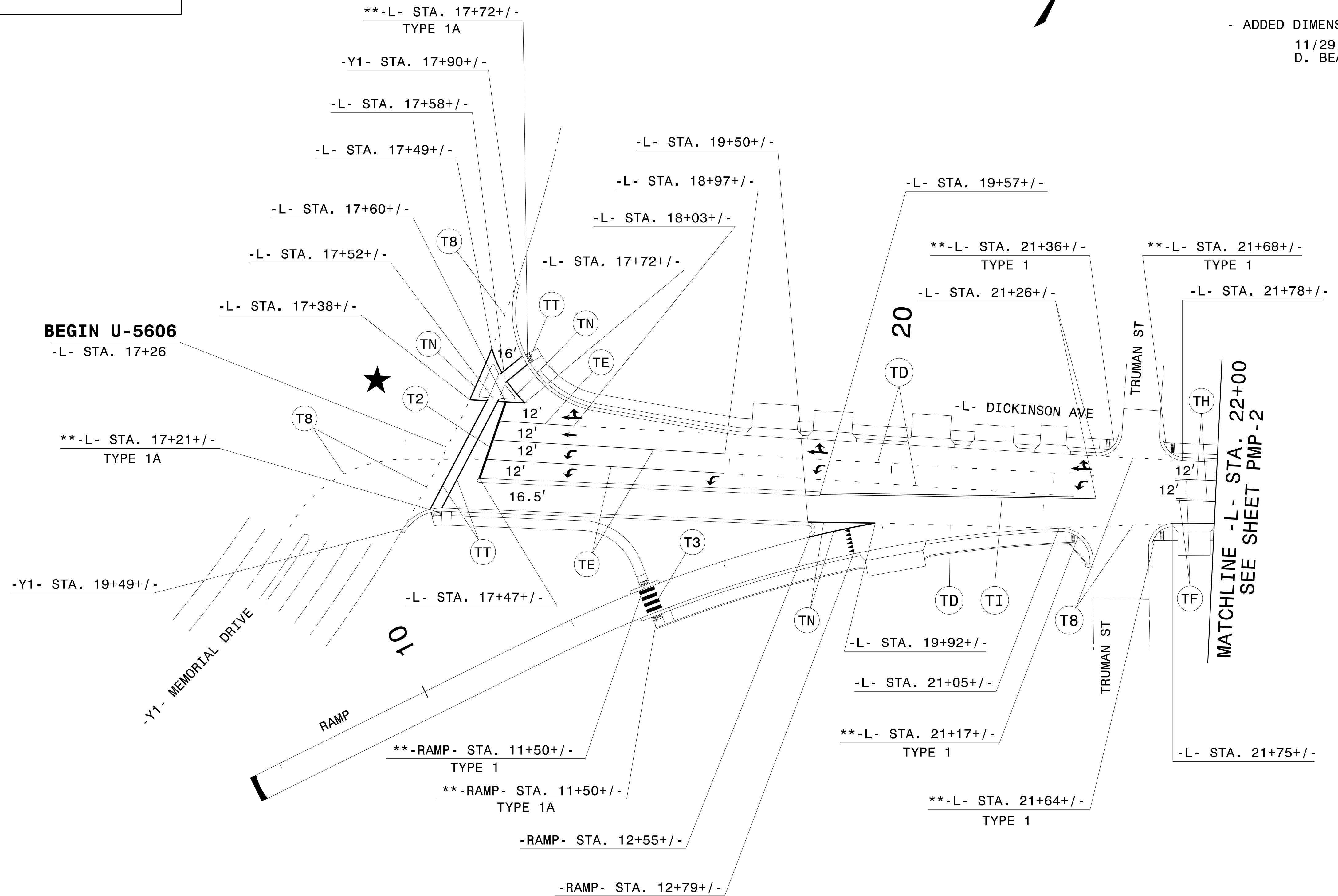

- ADDED DIMENSIONS AT INTERSECTION OF -Y1- AND -L-
11/29/21
D. BEARD



11/30/21
 P:\TIP\Projects-U\U5606\Traffic\Signing\VCADD\PM\U-5606-PMP-2_11-29-21 REV.dgn
 User:dhbeard

PAVEMENT MARKING DETAIL

SYMBOL LEGEND	
	UC STRAIGHT ARROW
	UA LEFT ARROW
	UB RIGHT ARROW
	UE COMBO RIGHT/ STRAIGHT ARROW
	UI ALPHANUMERIC CHARACTER

** DUE TO THE COMPLEX NATURE OF THE SIDEWALKS AND STREETScape PLANS,
THE CURB RAMPS ARE SHOWN AS A GUIDE. REFER TO THE STREETScape
AND ALTERNATE CURB RAMP DESIGNS IN THE PLANS.

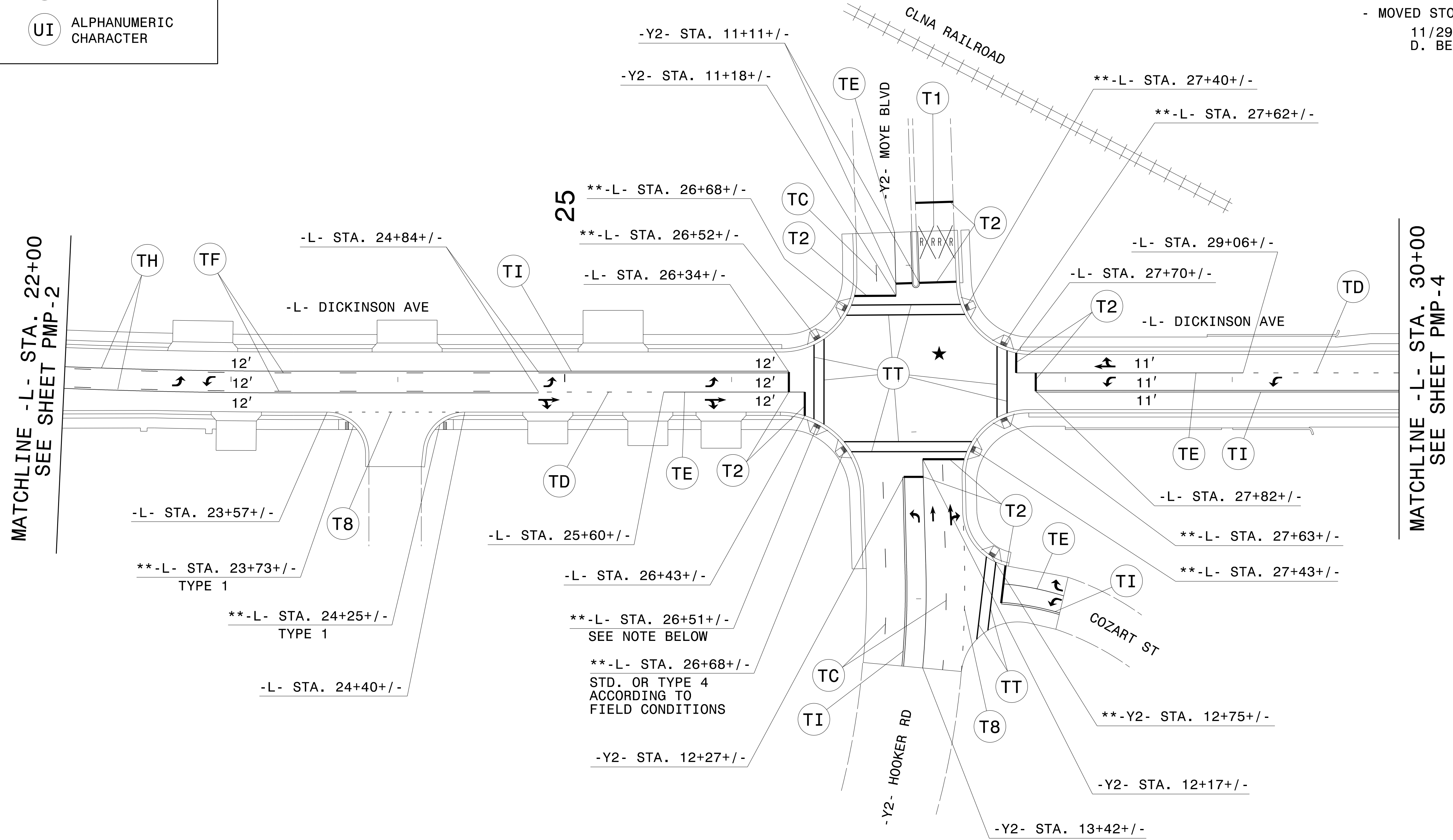
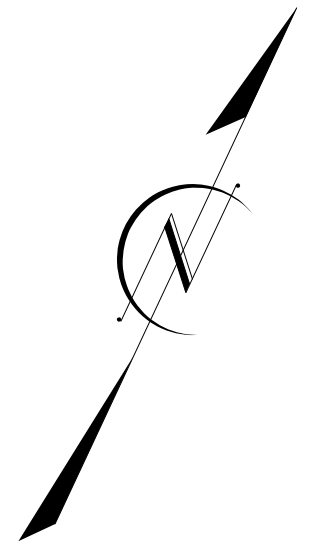

11/30/21
P:\TIP\Projects-U\U5606\Traffic\Signing\VCADD\VCADD\VCADD\U-5606-PMP-3 11-29-21 REV.dgn
User:dhbeard

PAVEMENT MARKING DETAIL

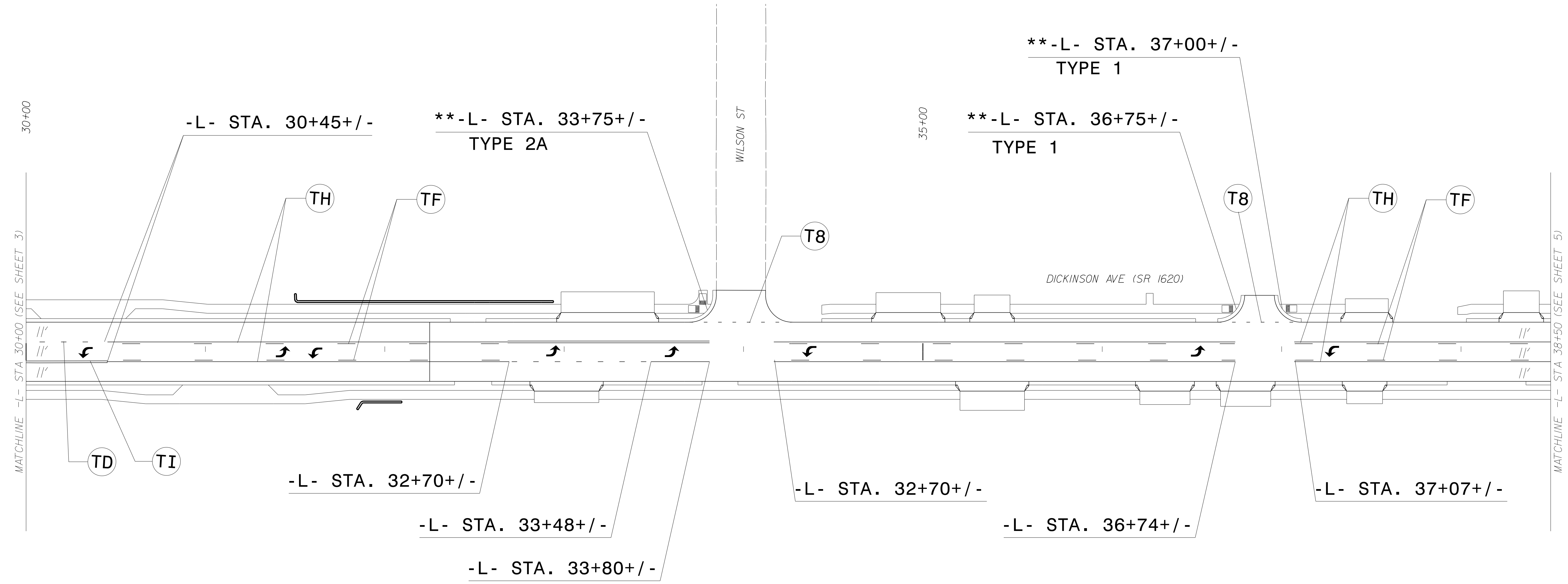
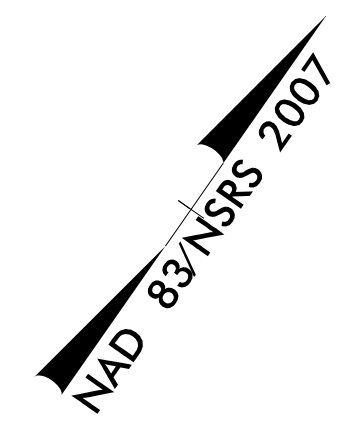

SYMBOL LEGEND	
	UC STRAIGHT ARROW
	UA LEFT ARROW
	UB RIGHT ARROW
	UE COMBO. RIGHT/ STRAIGHT ARROW

** DUE TO THE COMPLEX NATURE OF THE SIDEWALKS AND STREETSCAPE PLANS, THE CURB RAMPS ARE SHOWN AS A GUIDE. REFER TO THE STREETSCAPE AND ALTERNATE CURB RAMP DESIGNS IN THE PLANS.

PAVEMENT MARKING DETAIL

03/20/18
 P:\TIP\Projects-U\U5606\Traffic\Signmg\CADD\PMU\U5606_pmp_psh_s04.dgn
 User:rtward

APPROVED: *Ayman Alqudwah*
Professional Engineer
 F32ACSCAF965472
 DATE: 3/21/2018

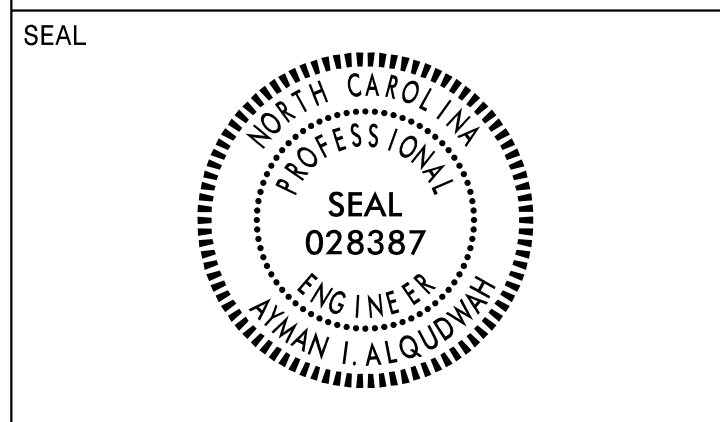

**DOCUMENT NOT CONSIDERED FINAL
 UNLESS ALL SIGNATURES COMPLETED**

SYMBOL LEGEND	
	UC STRAIGHT ARROW
	UA LEFT ARROW
	UB RIGHT ARROW
	UE COMBO. RIGHT/ STRAIGHT ARROW

**** DUE TO THE COMPLEX NATURE OF THE SIDEWALKS AND STREETScape PLANS.
 THE CURB RAMPS ARE SHOWN AS A GUIDE. REFER TO THE STREETScape
 AND ALTERNATE CURB RAMP DESIGNS IN THE PLANS.**

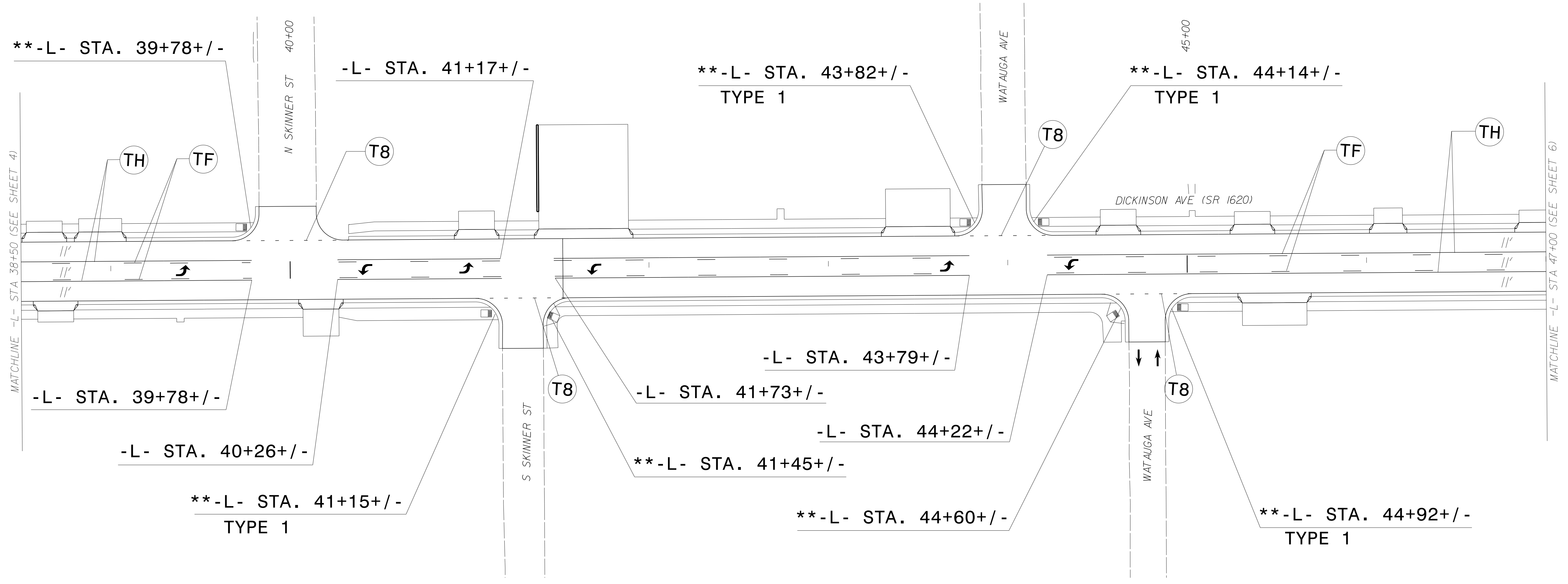
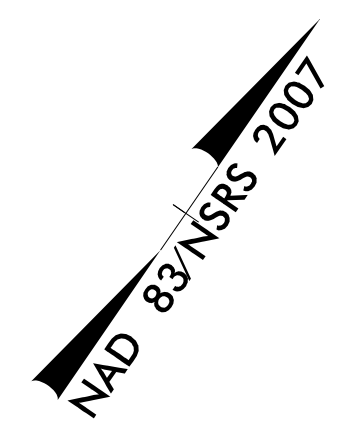

03/20/18
 P:\TIP-Projects\U5606\Traffic\Signing\CAOD\pmp\U5606_pmp_psh_s05.dgn
 User:rtward

PAVEMENT MARKING DETAIL

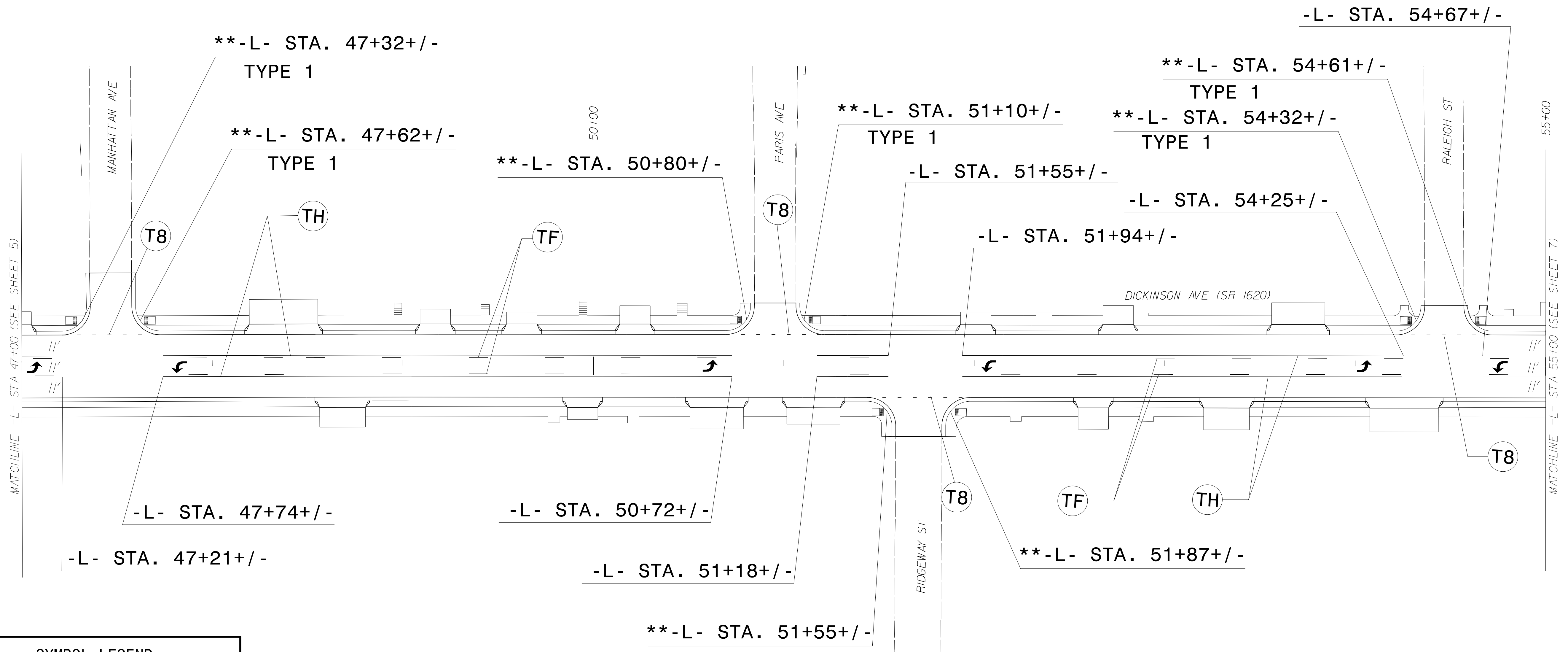
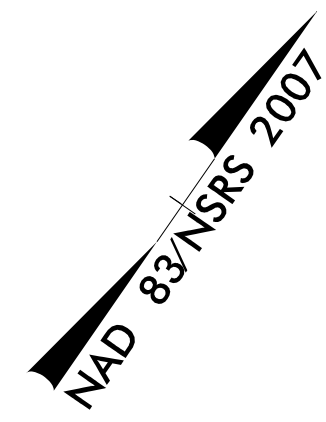



SYMBOL LEGEND	
	UC STRAIGHT ARROW
	UA LEFT ARROW
	UB RIGHT ARROW
	UE COMBO. RIGHT/ STRAIGHT ARROW

** DUE TO THE COMPLEX NATURE OF THE SIDEWALKS AND STREETScape PLANS. THE CURB RAMPS ARE SHOWN AS A GUIDE. REFER TO THE STREETScape AND ALTERNATE CURB RAMP DESIGNS IN THE PLANS.

PAVEMENT MARKING DETAIL

03/20/18
 P:\TIP\Projects\U5606\Traffic\Signmg\CADD\PMU\U5606.pmp_psh_s06.dgn
 User:rtward

SYMBOL LEGEND	
	UC STRAIGHT ARROW
	UA LEFT ARROW
	UE COMBO RIGHT/ STRAIGHT ARROW

** DUE TO THE COMPLEX NATURE OF THE SIDEWALKS AND STREETSCAPE PLANS,
THE CURB RAMP ARE SHOWN AS A GUIDE. REFER TO THE STREETSCAPE
AND ALTERNATE CURB RAMP DESIGNS IN THE PLANS.

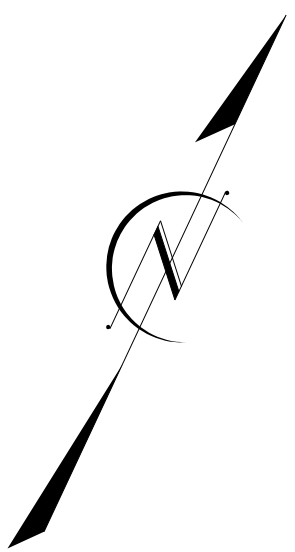

- UPDATED MARKINGS AT INTERSECTION
11/29/21
D. BEARD

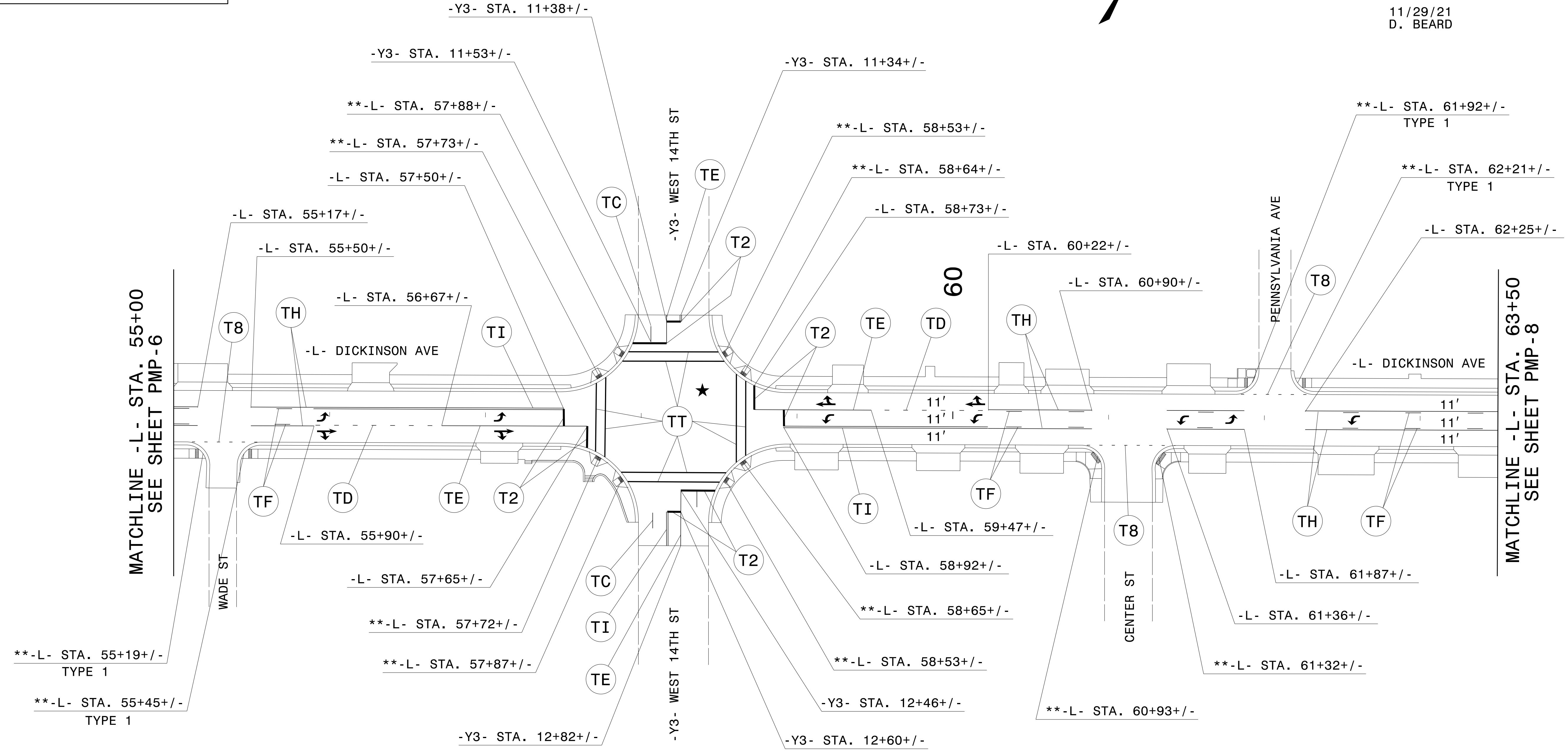

11/30/21
P:\TIP\Projects-U\U5606\Traffic\Signing\VCADD\MP\U-5606-PMP-7 11-29-21 REV.dgn
User:dhbeard

PAVEMENT MARKING DETAIL

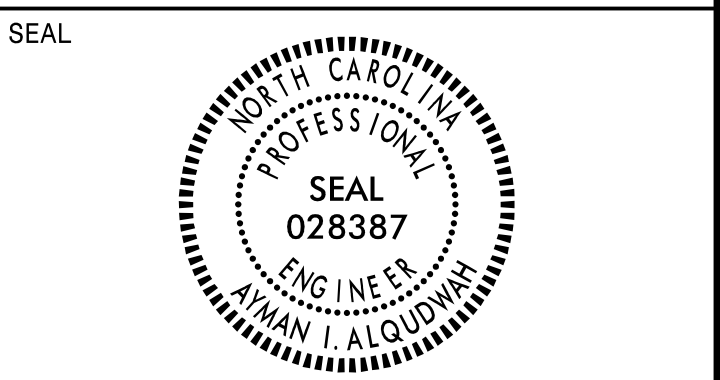

DOCUMENT NOT CONSIDERED FINAL
 UNLESS ALL SIGNATURES COMPLETED

SYMBOL LEGEND	
	UC STRAIGHT ARROW
	UA LEFT ARROW
	UB RIGHT ARROW
	UE COMBO RIGHT/ STRAIGHT ARROW
	UI ALPHANUMERIC CHARACTER

** DUE TO THE COMPLEX NATURE OF THE SIDEWALKS AND STREETScape PLANS,
 THE CURB RAMPS ARE SHOWN AS A GUIDE. REFER TO THE STREETScape
 AND ALTERNATE CURB RAMP DESIGNS IN THE PLANS.

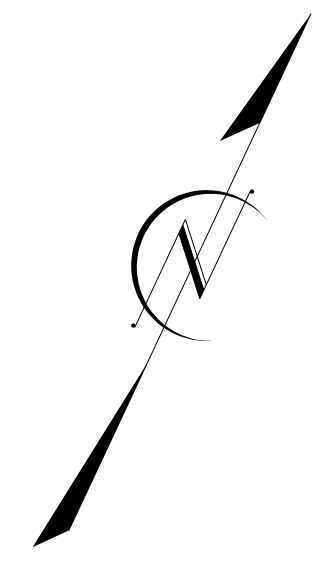

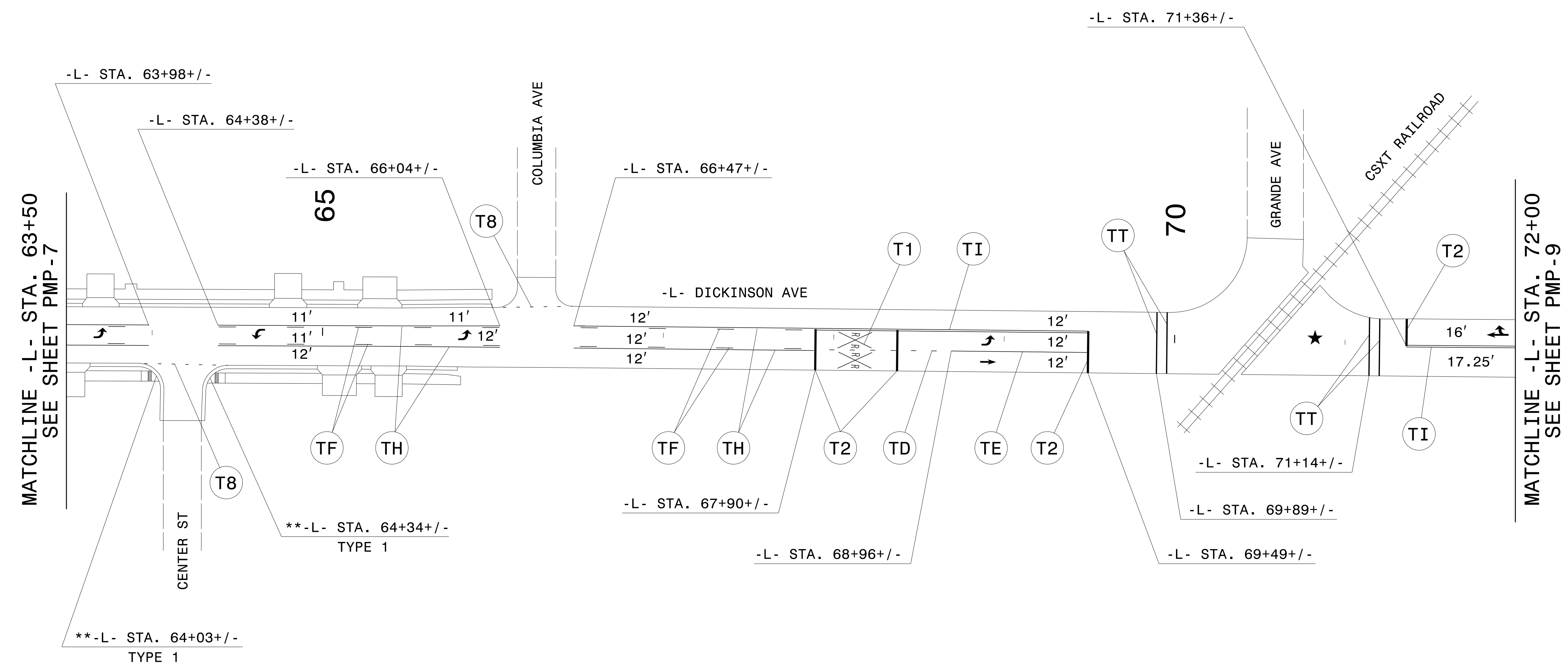

- ADDED MARKINGS TO DICKINSON AVE FROM
 COLUMBIA AVE TO -L- STA 72+00
 11/29/21
 D. BEARD

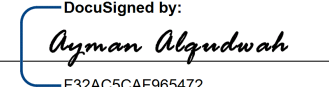

11/30/21
 P:\TIP\Projects-U\U5606\Traffic\Signing\CADD\PM\U-5606-PMP-8 11-29-21 REV.dgn
 User:dhbeard

PAVEMENT MARKING DETAIL

TIP NO.	SHEET NO.
U-5606	PMP-9
APPROVED: 	
DATE: NOV 30, 2021	
	
DOCUMENT NOT CONSIDERED FINAL UNLESS ALL SIGNATURES COMPLETED	

SYMBOL LEGEND	
R	ALPHANUMERIC CHARACTER
UI	

** DUE TO THE COMPLEX NATURE OF THE SIDEWALKS AND STREETScape PLANS, THE CURB RAMPS ARE SHOWN AS A GUIDE. REFER TO THE STREETScape AND ALTERNATE CURB RAMP DESIGNS IN THE PLANS.

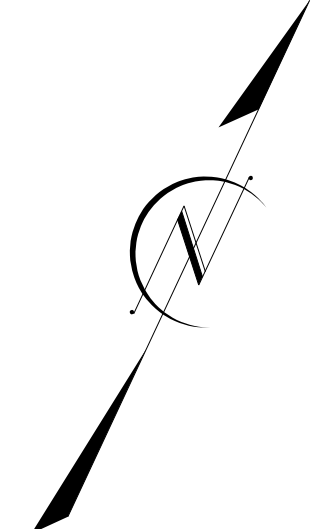

- ADDED DIMENSIONS FROM -L- STA. 72 TO -L- STA. 74.
- ADJUSTED CURB RAMPS AT W. 9TH ST.
11/29/21
D. BEARD

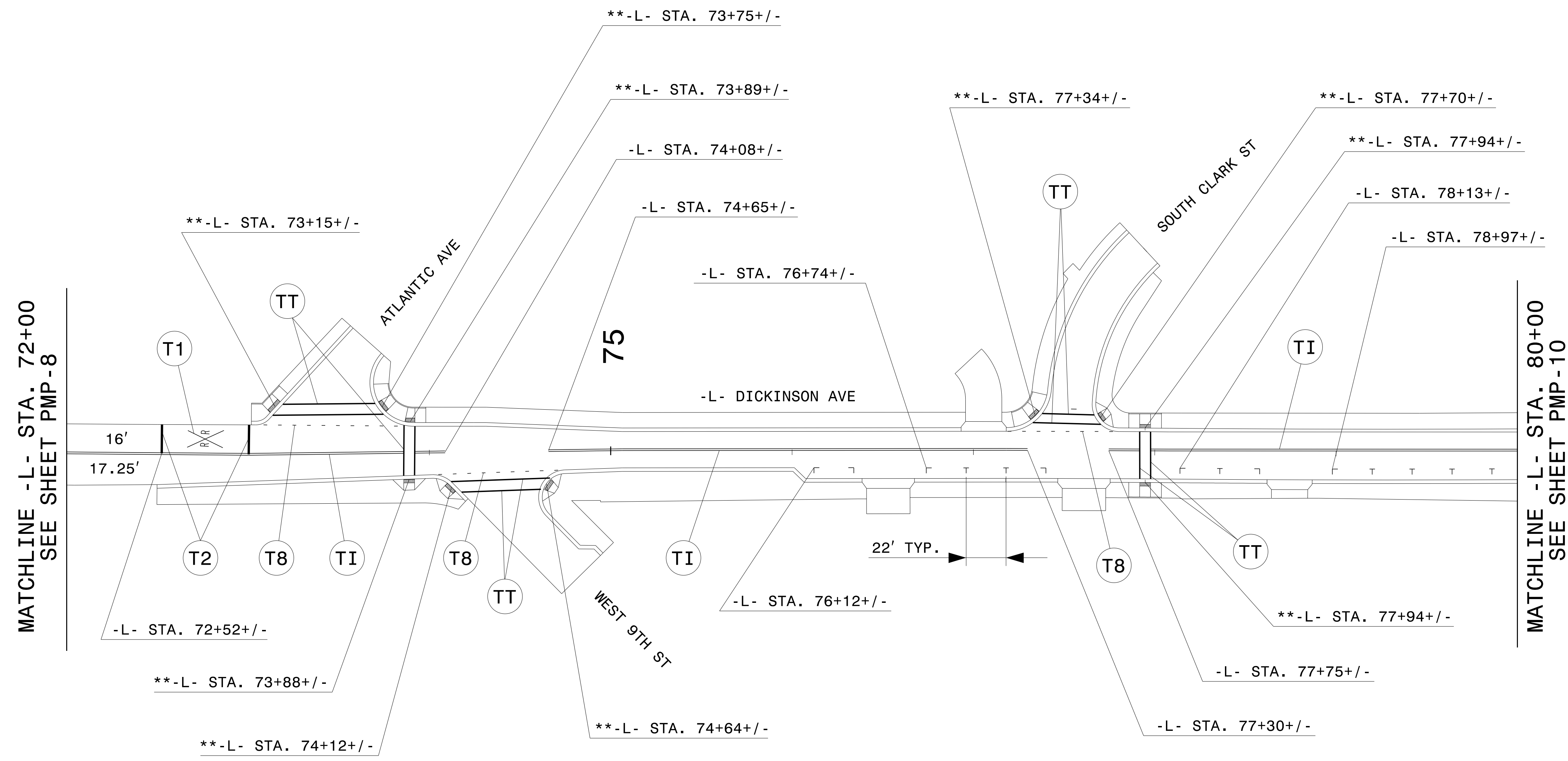



MATCHLINE -L- STA. 72+00
SEE SHEET PMP-8

MATCHLINE -L- STA. 80+00
SEE SHEET PMP-10

11/30/21
P:\TIP\Projects-U\U5606\Traffic\Signing\CADD\MP\U-5606-PMP-9 11-29-21 REV.dgn
User:dhbeard

PAVEMENT MARKING DETAIL

SYMBOL LEGEND	
	UC STRAIGHT ARROW
	UA LEFT ARROW
	UE COMBO RIGHT/ STRAIGHT ARROW

** DUE TO THE COMPLEX NATURE OF THE SIDEWALKS AND STREETScape PLANS, THE CURB RAMPS ARE SHOWN AS A GUIDE. REFER TO THE STREETScape AND ALTERNATE CURB RAMP DESIGNS IN THE PLANS.

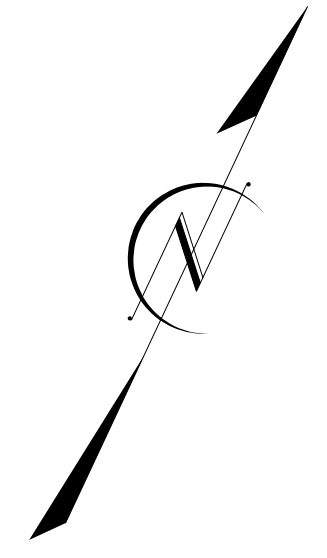

- MOVED STOPBARS AT DICKINSON AVE / READE CR INTERSECTION
 - ADJUSTED CURB RAMP LOCATIONS ON S. PITT ST.
 11/29/21
 D. BEARD

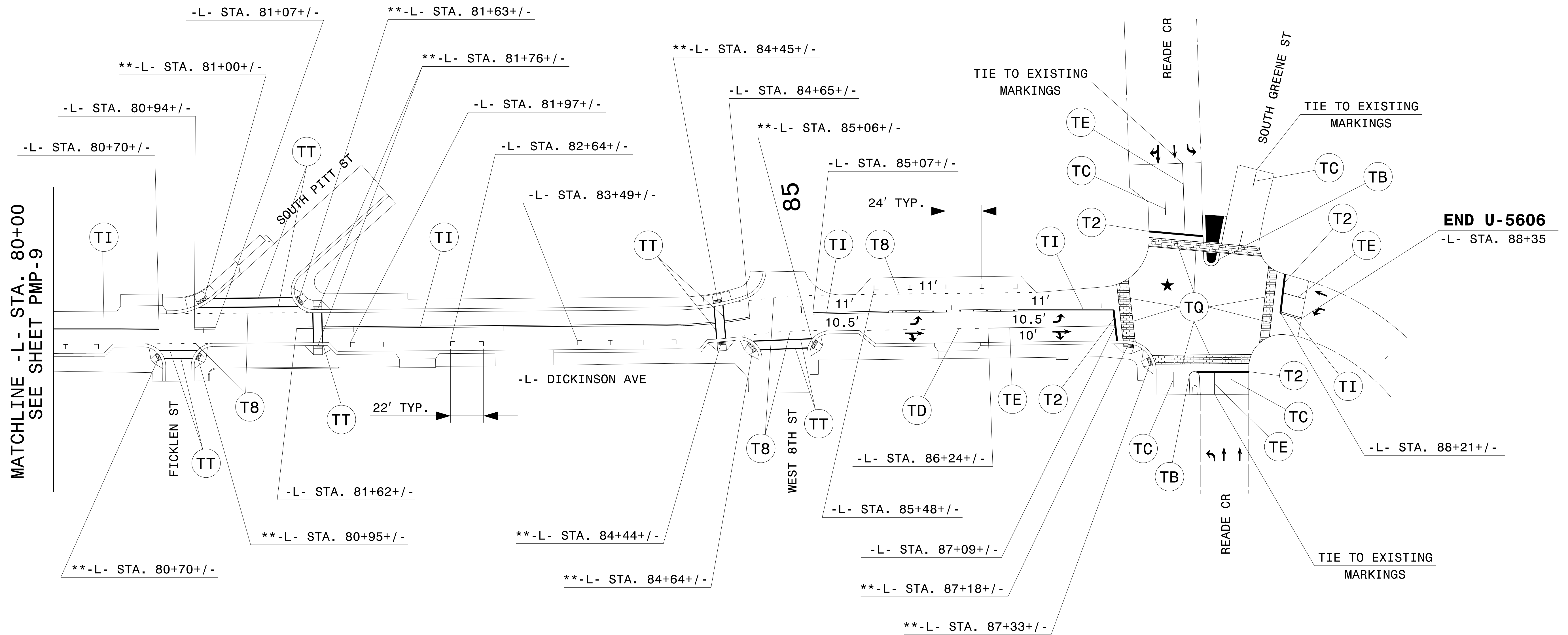

MATCHLINE -L- STA. 80+00
SEE SHEET PMP-9

END U-5606
-L- STA. 88+35

11/30/21
P:\TIP\Projects-U\U5606\Trat\fic\Signing\CADD\MP\U-5606-PMP-10_11-29-21REV.dgn
User:dhbeard

PAVEMENT MARKING DETAIL