

5/14/99

2016 ADT
2036 ADT

-Y2- MOYE BOULEVARD (SR 1139)

DH/V = 10%
DIR = 65%
TTST = 1%
DUAL = 2%

10500 600 1400 13000
11700 900 1800 14600

DICKINSON AVENUE (SR 1598)

1100 2800 3500
1500 14000

-Y2- HOOKER ROAD

DH/V = 9%
DIR = 55%
TTST = 1%
DUAL = 2%

-L-
PI Sta 22+35.26
D = 3' 21' 08.7" (LT)
D = 1' 38' 13.3"
L = 204.79'
T = 102.42'
R = 3,500.00'
SE = SEE PLANS
RO = SEE PLANS

-Y2-
PI Sta 13+76.05
D = 22' 00' 37.0" (RT)
D = 1' 27' 53.0"
L = 192.08'
T = 97.24'
R = 500.00'
SE = EXISTING
RO = EXISTING

PREPARED IN THE OFFICE OF:

THE WOOTEN COMPANY
120 North Roper Avenue Raleigh, NC 27603-1423
919.876.0311 Fax 919.876.0309
License Number: F-0115

PROJECT REFERENCE NO. **U-5606** SHEET NO. **UC-5**

DESIGNED BY: JRG
DRAWN BY: TK & CB
CHECKED BY: DGM
APPROVED BY: DGM

REVISED:

NORTH CAROLINA DEPARTMENT OF TRANSPORTATION

UTILITIES ENGINEERING SEC.
PHONE: (919) 707-6690
FAX: (919) 250-4151

Document Not Considered Final
Unless All Signatures Completed
UTILITY CONSTRUCTION PLANS ONLY

VERTICAL SCALE
0 5' 10'

HORIZONTAL SCALE
15' 0 15' 30'

WATER LINE AND SEWER LINE CONSTRUCTION SHOWN ON THIS SHEET

PHASING SECTION 1
(-L-, STA. 17+26 TO STA. 27+50)

PHASING SECTION 2
(-L-, STA. 27+50 TO STA. 32+25)

UTILITY CONSTRUCTION

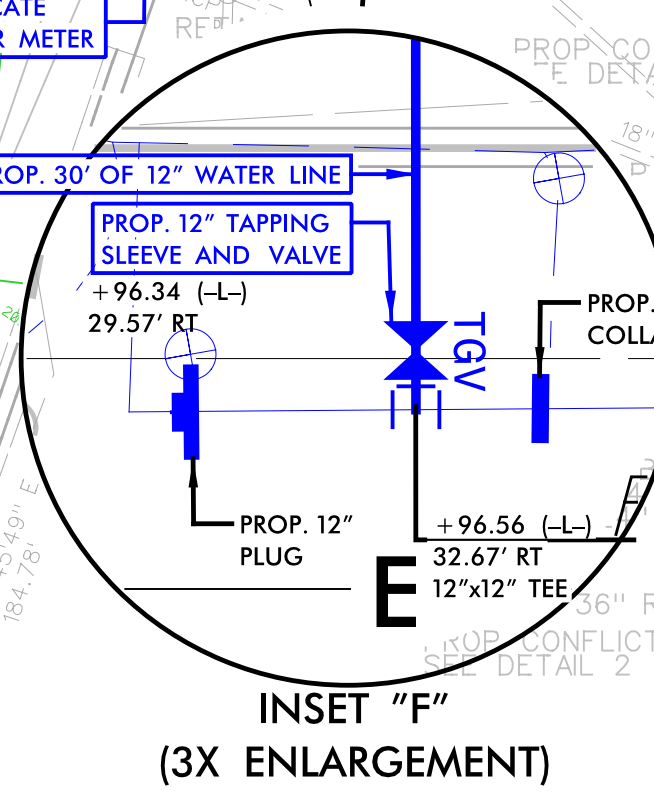
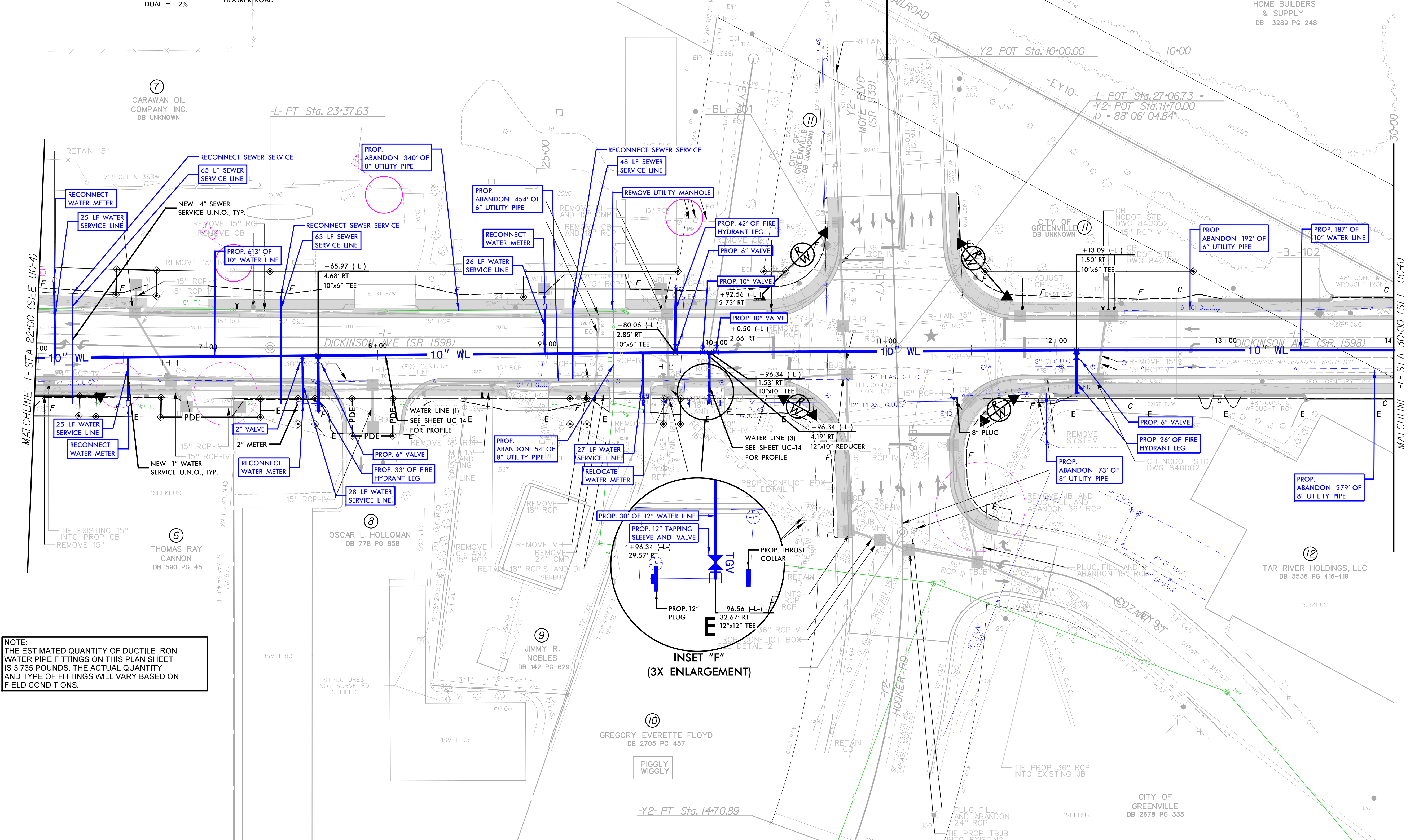

NOTE:
THE ESTIMATED QUANTITY OF DUCTILE IRON WATER PIPE FITTINGS ON THIS PLAN SHEET IS 3,735 POUNDS. THE ACTUAL QUANTITY AND TYPE OF FITTINGS WILL VARY BASED ON FIELD CONDITIONS.

SEE SHEET 13 FOR -L- PROFILE