

ECONOLITE ASC/3-2070 RAILROAD PREEMPT PROGRAMMING DETAIL

(program controller as shown)

- From Main Menu select **4. PREEMPTOR/TSP**
- From PREEMPTOR/TSP/SCP Submenu select **1. PREEMPT PLAN 1-10**

Place cursor in [] next to Preempt Plan and press 1. Then press the right cursor arrow and toggle the controller to YES. Next cursor down. This will select Railroad Preempt #1.

PREEMPT PLAN [1]	ENABLE....YES
VEH/PED 1 2 3 4 5 6 7 8 9 0 1 2 3 4 5 6	
OVERLAP A B C D E F G H I J K L M N O P	
TRKCLR V . . . X . . . X	
TRKCLR O . . . F1	
ENA TRL	
DWEL VEH	
DWEL PED	
DWEL OLP	
CYC VEH . X X . . X	
CYC PED . X . . . X	
CYC OLP F1F1	
EXIT PH . . X . . . X	
EXIT CAL	
SP FUNC	

ENABLE... YES	IPMT	OVERRIDE	X	INTERLOCK	NO
DET LOCK... X	DELAY..	O	INHIBIT... 0		
OVERIDE FL. .	DURATION	O	ICLR-GRN... NO		
TERM OLP. NO	IPC>YEL	YES	TERM PH NO		
PED DARK.. NO	ITC RESRV	YES	DWELL FL OFF		
LINK PMT...O	X FLCOLR	RED	EXIT OPT. OFF		
X TMG PLN...O	IRE-SERV..	O	FLT TYPE.HARD		
FREE DUR PMT	IR1 NOIR2	NOIR3	NOIR4 NO		
--TIMING----	WALKIPED	CLIMN	GRI YELI RED		
ENTRANCE TM.	11 31	1125.5	125.5		
-----MIN	GRIEXT	GRIMX	GRI YELI RED		
TRACK CLEAR	241 0.01	0125.5	125.5		
-----MIN	DLIPMTEXT	IMX TMI	YELI RED		
DWL/CYC-EXIT	71 0.01	0125.5	125.5		
PMT ACTIVE OUT..	ON	PMT ACT	DWELL...NO		
OTHER - PRI	PMT.OFF	NON-PRI	PMT....OFF		
INH EXT TIME... 0.0	PED PR	RETURN...OFF			
PRIORITY RETURN.OFF	QUEUE	DELAY.... OFF			
COND DELAY.....OFF					
PHASES	1 2 3 4 5 6 7 8				
PR RTN%	0 0 0 0 0 0 0 0				
PHASES	9 10 11 12 13 14 15 16				
PR RTN%	0 0 0 0 0 0 0 0				

RAILROAD PREEMPTION WIRING DETAIL

(wire as shown below)

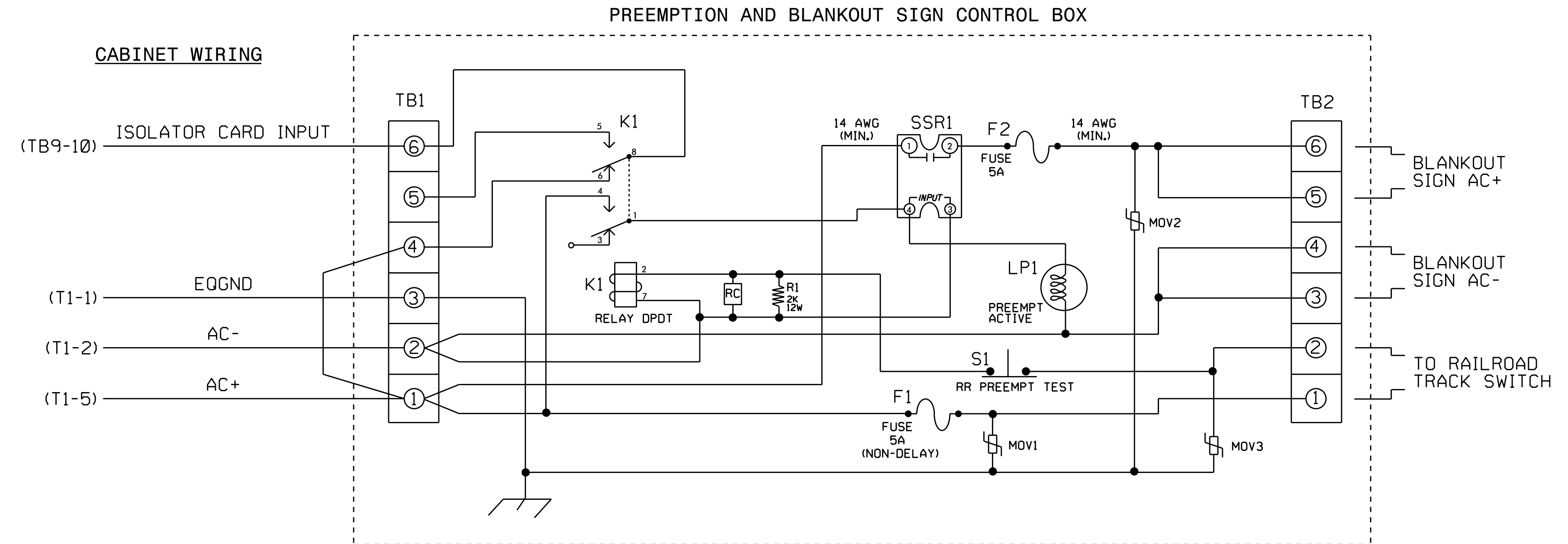

NOTES

- Relay K1 is shown in the energized (Preempt not active) normal operation state.
- Relay K1 is a DPDT with 120VAC coil with octal base.
- Relay SSR1 is a SPST (normally open) Solid State Relay with AC input and AC (25 amp) output.
- AC Isolator Card shall activate preemption upon removal of AC+ from the input (as shown above). To accomplish this set invert dip switch on AC Isolator Card as shown on the detail on this sheet.
- IMPORTANT!!** A jumper must be added between input file terminals J14-E and J14-K if not already present. Also, terminal TB9-12 (on input panel) shall be connected to AC neutral (jumper may have to be added).

FRONT VIEW

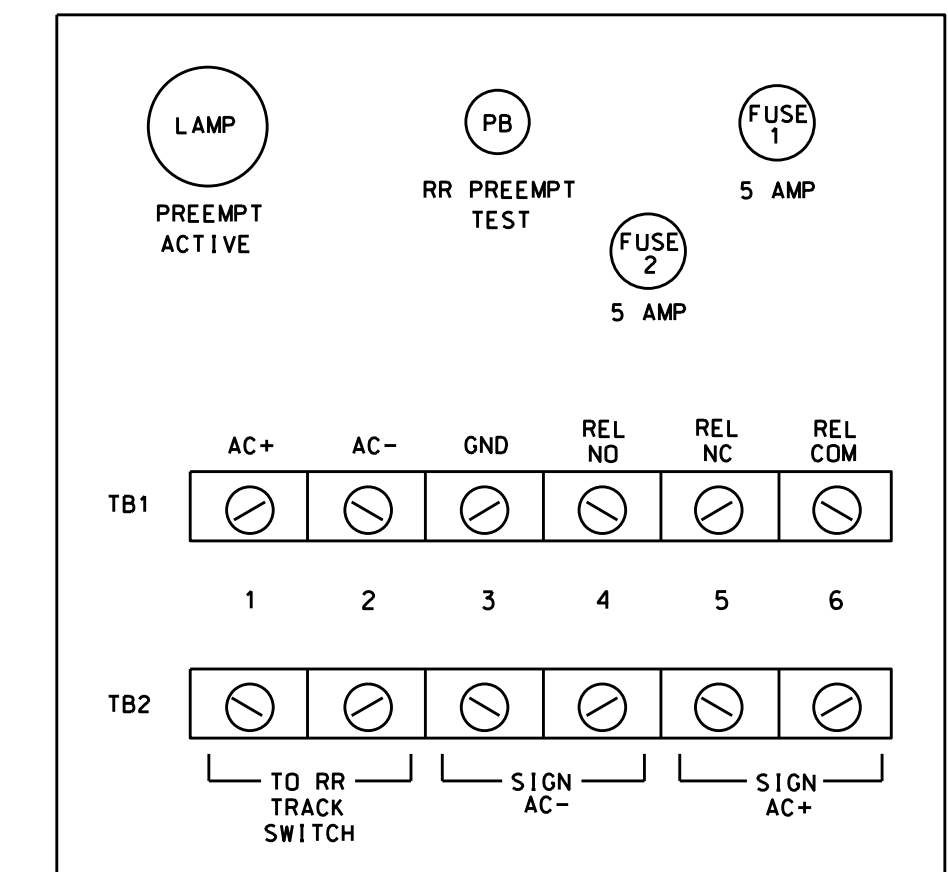

PREEMPT 1 AC ISOLATOR (MODEL 252) OUTPUT PROGRAMMING DETAIL

(set DIP switches as shown below)

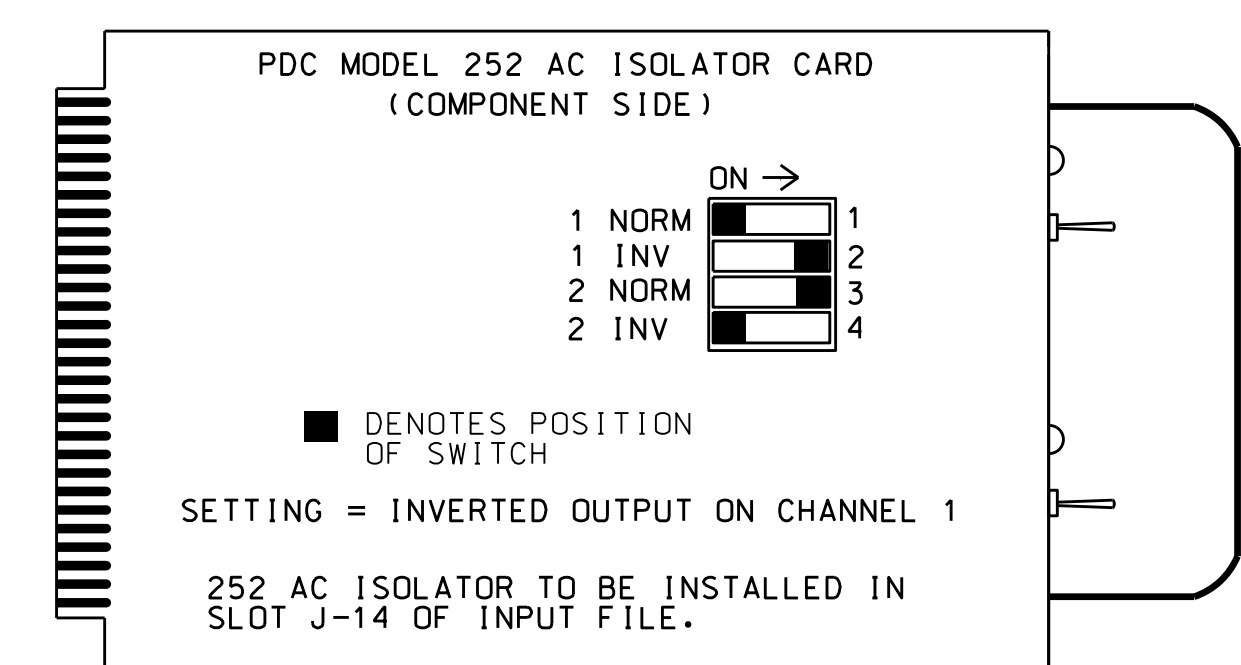

NOTE: IF ANOTHER MANUFACTURER TYPE OF AC ISOLATOR IS USED, OUTPUT PROGRAMMING IS LIKELY NOT TO EQUATE TO THAT SHOWN ABOVE.

THIS ELECTRICAL DETAIL IS FOR THE SIGNAL DESIGN: 02-0004
 DESIGNED: November 2021
 SEALED: 11/16/2021
 REVISED: N/A

Electrical Detail - Sheet 3 of 3

ELCTRICIAL AND PROGRAMMING DETAILS FOR: SR 1598 (Dickinson Avenue) at SR 1701 (Hooker Rd)/ SR 1709 (Moye Boulevard)

Division 2 Pitt County Greenville

PLAN DATE: February 2018 REVIEWED BY:

PREPARED BY: S. Armstrong REVIEWED BY:

REVISIONS: No electrical changes. (WSA)

DATE: 11/17/21

750 N. Greenfield Pkwy, Garner, NC 27529

DOCUMENT NOT CONSIDERED FINAL UNLESS ALL SIGNATURES COMPLETED

REVISION SEAL

SEAL 036833

RYAN W. HOUGH ENGINEER

11/17/2021 DATE

Not a certified document as to the Original Document but only as to the Revisions - This document originally issued and sealed by Keith M. Mims, #036880, on 2/26/2018. This document is only certified as to the revisions.

SIG. INVENTORY NO. 02-0004

17-0004-2021 12:00
 4/20/2024 Lemuel et al. v. WNC dgm
 5078171.dwg