

PROJECT REFERENCE NO.	SHEET NO.
U-5606	EC-16/CONST.8
RDW SHEET NO.	HYDRAULICS ENGINEER
ROADWAY DESIGN ENGINEER	

UTILIZE FABRIC INLET PROTECTION IN LIEU OF TYPE C INLET PROTECTION WHERE WATER MAY POND ON ROADWAY USED BY PUBLIC TRAFFIC

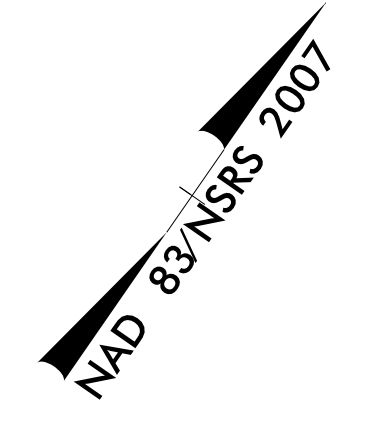

- NOTES:
- TIE TO EXIST CURB AND GUTTER AT EXIST CONCRETE JOINT TRANSITION 2'-6" C&G TO MATCH EXIST GUTTER WIDTH AS NECESSARY
 - TIE TO EXISTING CONCRETE SIDEWALK LIMITS OF PAVEMENT REMOVAL AND REPLACEMENT
 - ADJUSTMENT OF MANHOLE
 - ADJUSTMENT OF METER OR VALVE BOX
 - REMOVE AND STOCKPILE EXISTING GRANITE CURB
 - RETAIN EXISTING MAST ARM
 - TAPER CURB TO TIE TO EXIST GRANITE CURB

-L-
 PI Sta 48+77.02
 $\Delta = 0'12"40.6" (RT)$
 $D = 55.31'$
 $L = 27.65'$
 $R = 15,000.00'$
 SE = NC
 RO = NONE

REVISIONS

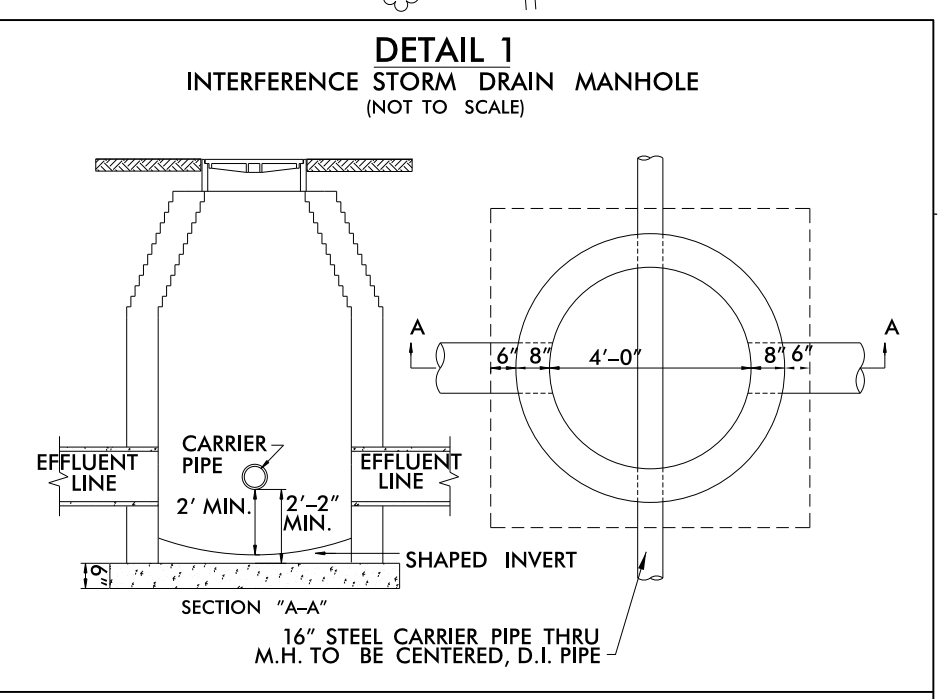
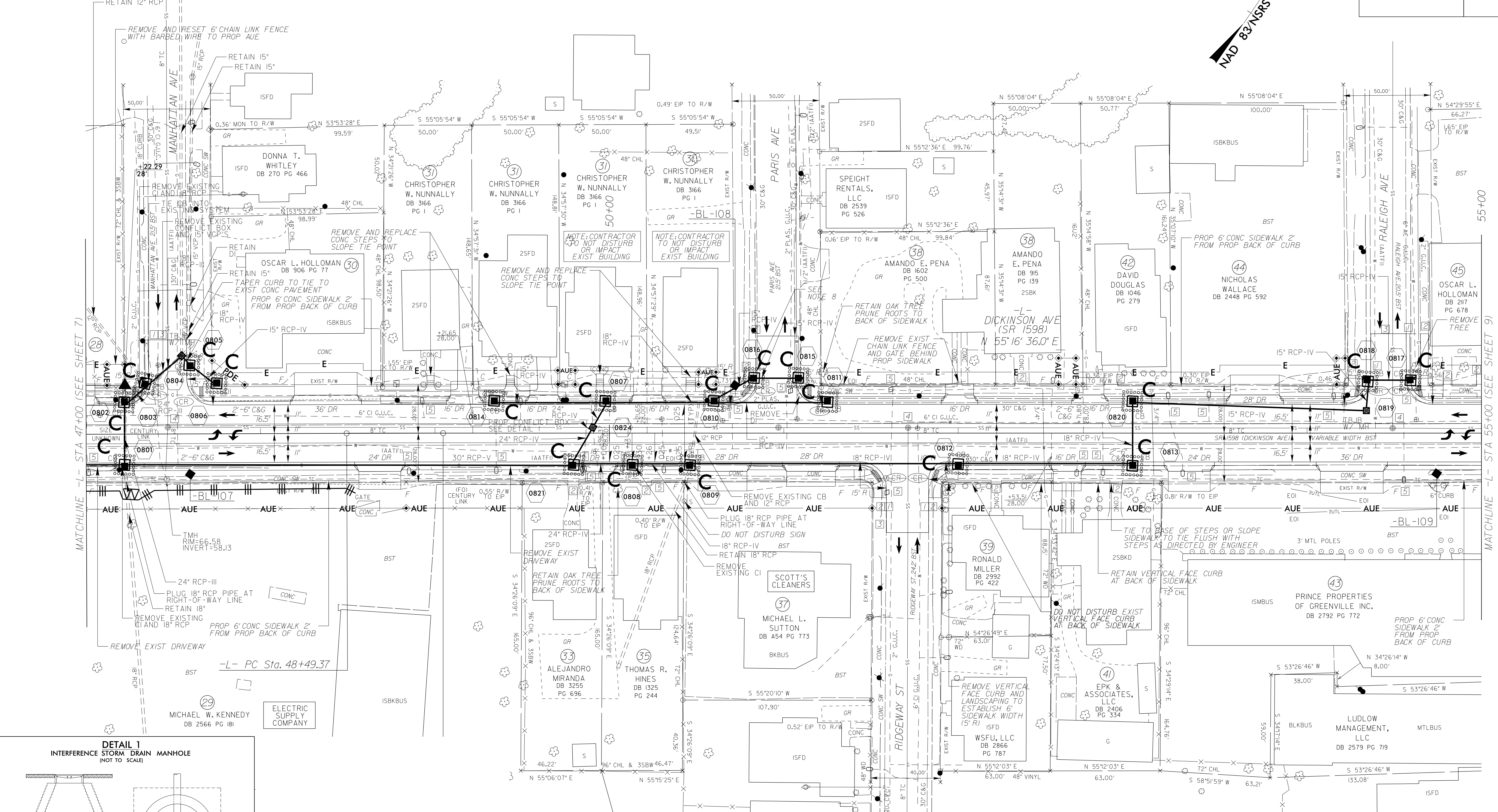

STA. 49+90 -L- (LT)
 REFER TO NCDOT ROADWAY STANDARD DRAWING 840.51 FOR MANHOLE DETAIL

SEE SHEET 15 FOR -L- PROFILE