

APPROVED: *Ayman Alqudwah*
Professional Engineer
 F32ACSCAF965472
 DATE: 3/21/2018

SEAL

**DOCUMENT NOT CONSIDERED FINAL
UNLESS ALL SIGNATURES COMPLETED**

SYMBOL LEGEND	
	UC STRAIGHT ARROW
	UA LEFT ARROW
	UB RIGHT ARROW
	UE COMBO. RIGHT/ STRAIGHT ARROW

**** DUE TO THE COMPLEX NATURE OF THE SIDEWALKS AND STREETScape PLANS.
THE CURB RAMPS ARE SHOWN AS A GUIDE. REFER TO THE STREETScape
AND ALTERNATE CURB RAMP DESIGNS IN THE PLANS.**

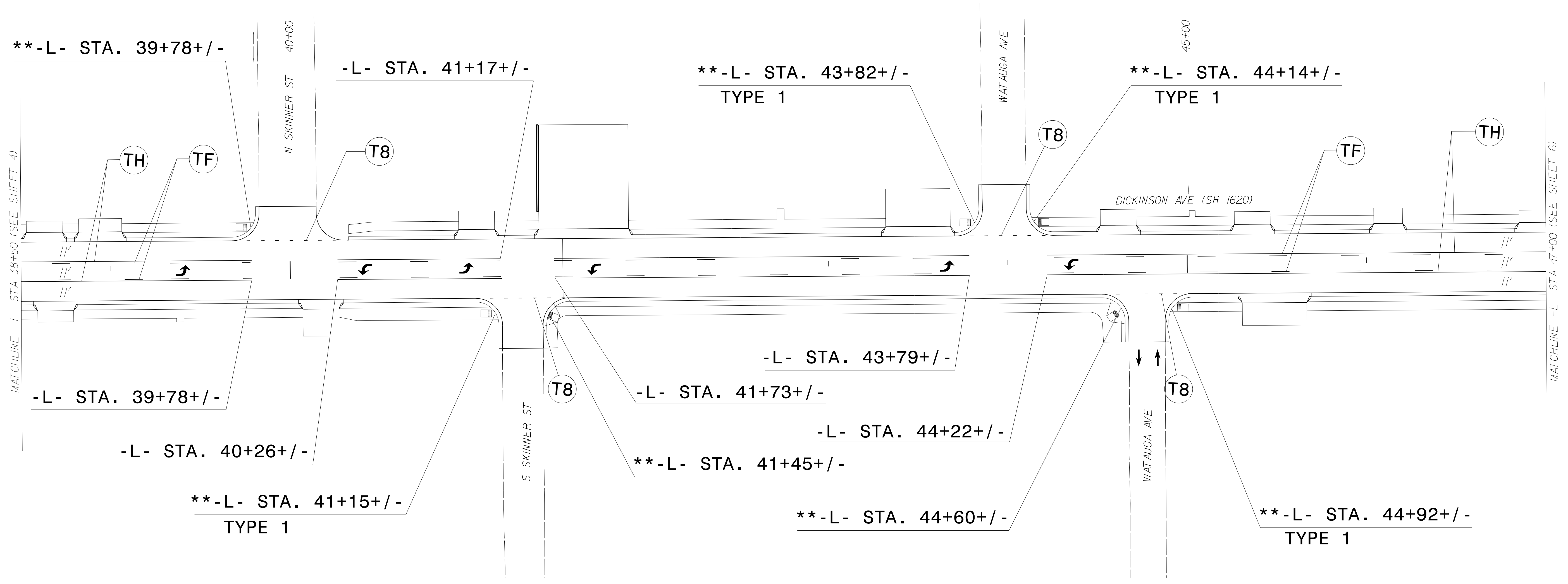
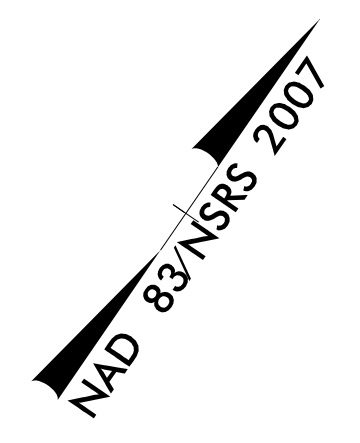

03/20/18
 P:\TIP-Projects\U5606\Traffic\Signing\CAOD\pmp\U5606_pmp_psh_s05.dgn
 User:rtward

PAVEMENT MARKING DETAIL