

LIMIT OF SILANE BARRIER RAIL APPLICATION.

NOTES:

REPAIR LOCATIONS AND ESTIMATED QUANTITIES ARE GIVEN WITH THE BEST INFORMATION AVAILABLE. IF ADDITIONAL REPAIRS NOT SHOWN ON THE DRAWINGS ARE DEEMED NECESSARY BY THE ENGINEER, THE ENGINEER WILL NOTE ON THE DRAWINGS THE APPROXIMATE LOCATIONS AND DESCRIPTION OF THE REPAIRS AND ADJUST QUANTITIES ENTERED INTO AS-BUILT REPAIR QUANTITY TABLE.

QUANTITY FOR SILANE DECK TREATMENT INCLUDES SIDEWALK.

QUANTITY FOR SILANE DECK TREATMENT FOR APPROACH SLAB INCLUDES SIDEWALK AND CURB.

FOR SILANE DECK TREATMENT, SEE SPECIAL PROVISIONS.

FOR SILANE BARRIER RAIL TREATMENT, SEE SPECIAL PROVISIONS.

APPROACH SLAB QUANTITIES

	ESTIMATE	ACTUAL
SHOTBLASTING APPROACH SLAB	84.7 SQ.YD.	
SILANE DECK TREATMENT	84.7 SQ.YD.	

BRIDGE DECK QUANTITIES

	ESTIMATE	ACTUAL
SHOTBLASTING BRIDGE DECK	704.2 SQ.YD.	
SILANE DECK TREATMENT	704.2 SQ.YD.	
SURFACE PREPARATION FOR CONCRETE BARRIER	405.0 SQ.FT.	
SILANE BARRIER RAIL TREATMENT	405.0 SQ.FT.	

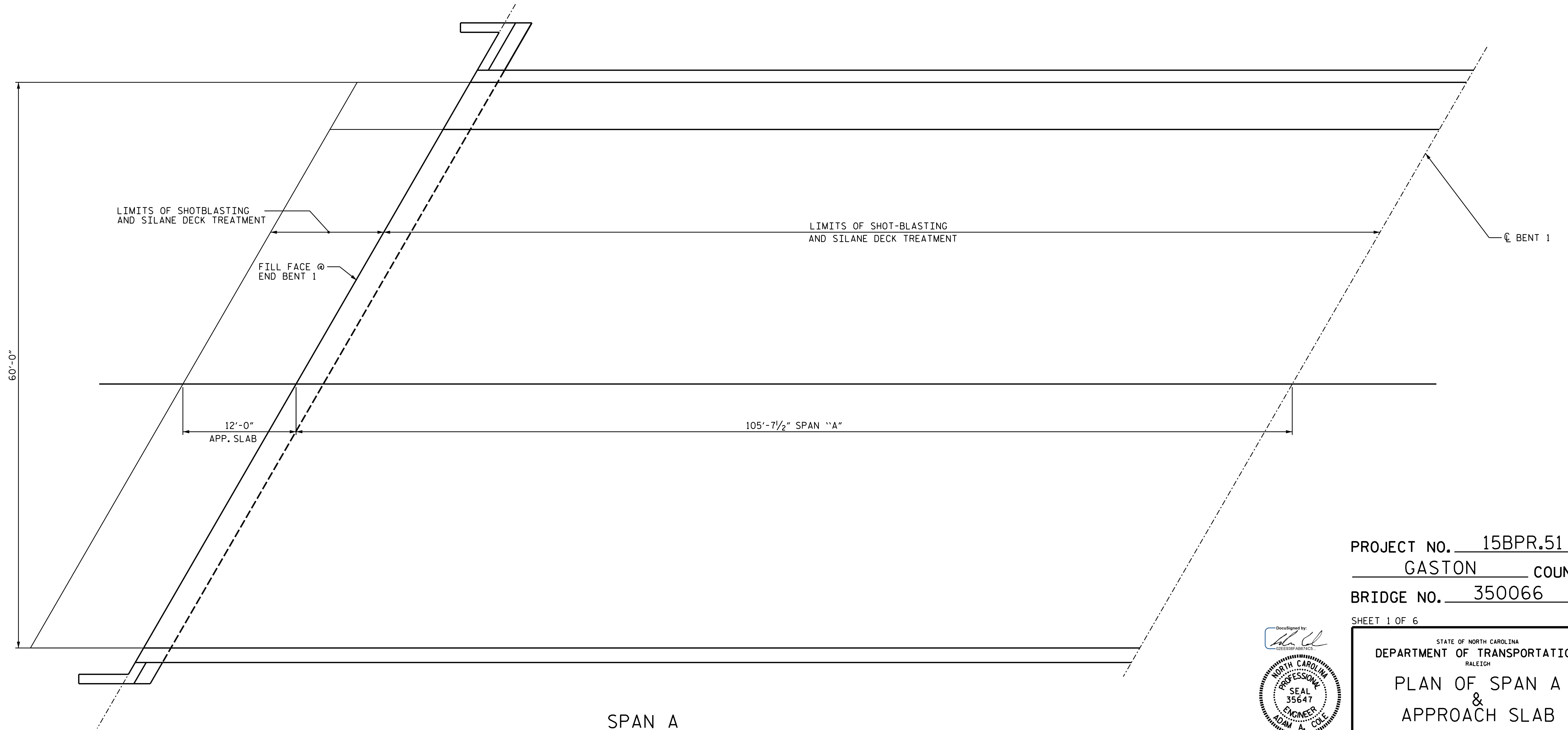

SPAN A

PROJECT NO. 15BPR.51
GASTON COUNTY
 BRIDGE NO. 350066

SHEET 1 OF 6

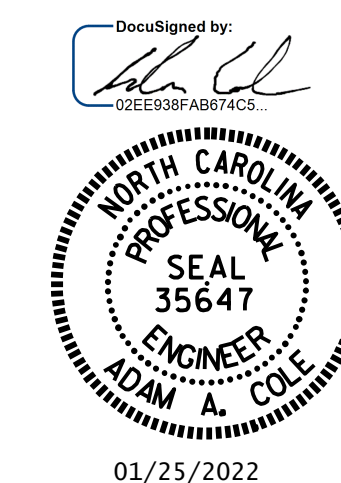

STATE OF NORTH CAROLINA
 DEPARTMENT OF TRANSPORTATION
 RALEIGH

PLAN OF SPAN A
 &
 APPROACH SLAB

DRAWN BY : GHOLAMREZA KOUCHEKI DATE : 10/2021
 CHECKED BY : H.A. LOCKLEAR DATE : 12/2021

DOCUMENT NOT CONSIDERED
 FINAL UNLESS ALL
 SIGNATURES COMPLETED

REVISIONS						SHEET NO.
NO.	BY:	DATE:	NO.	BY:	DATE:	
1			3			S4-05
2			4			TOTAL SHEETS 67