

EXISTING JOINT

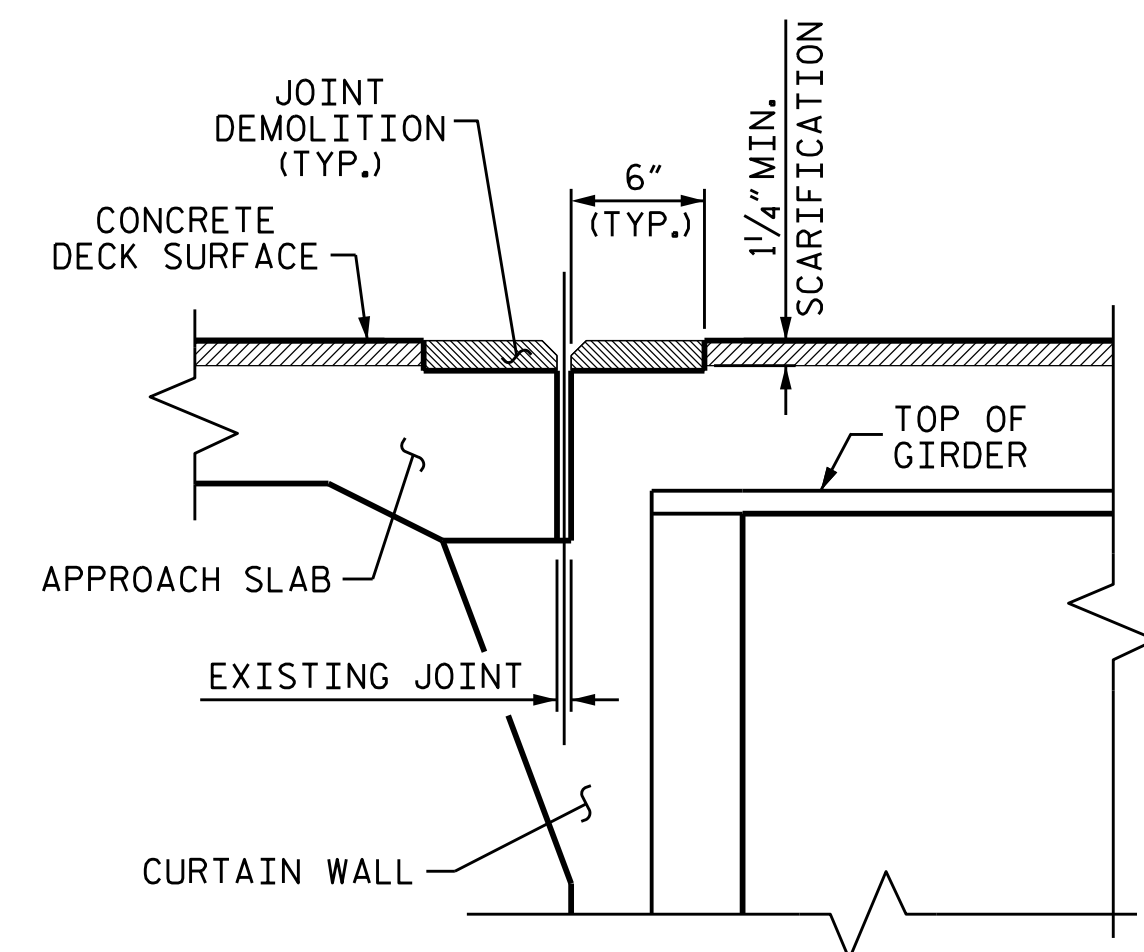

MINIMUM EXISTING JOINT DEMOLITION & SCARIFICATION

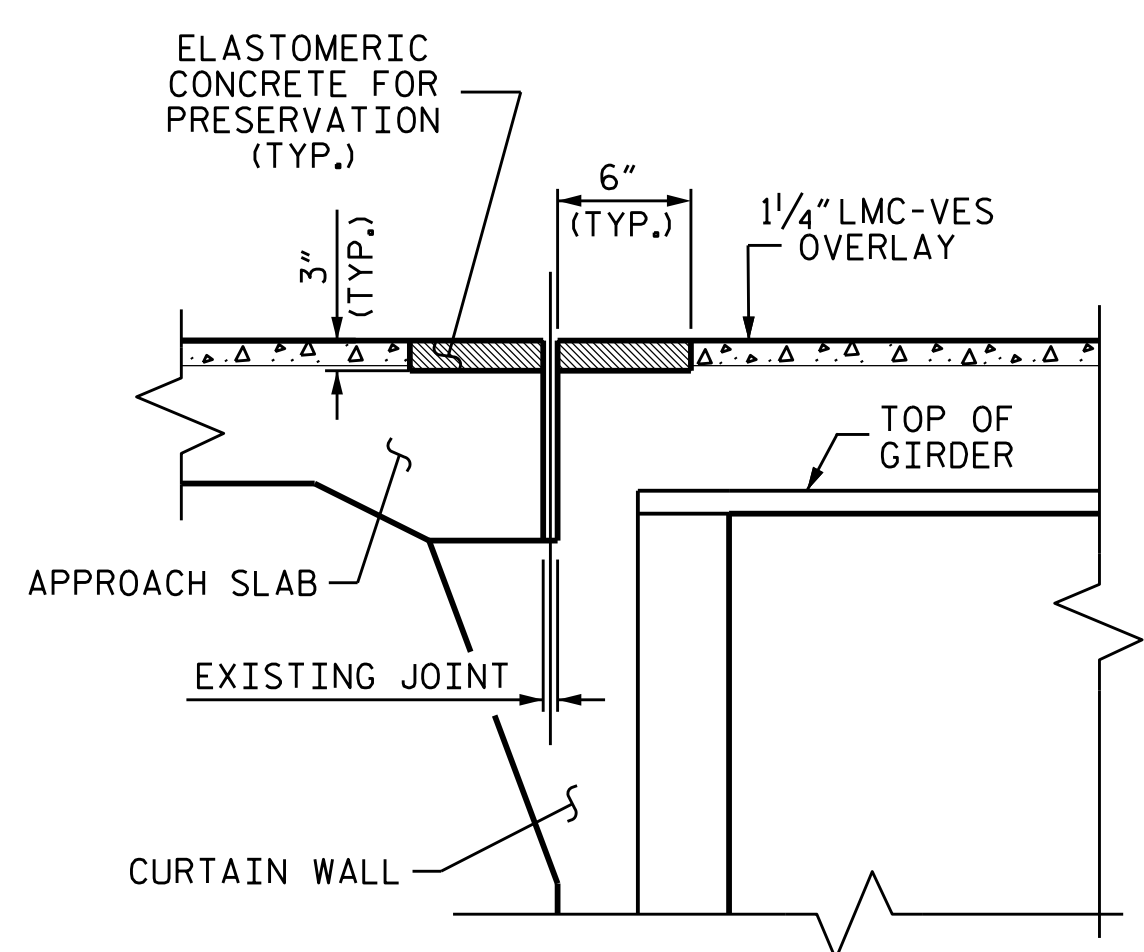

PROPOSED JOINT WITH PRE-SAWED DIMENSION

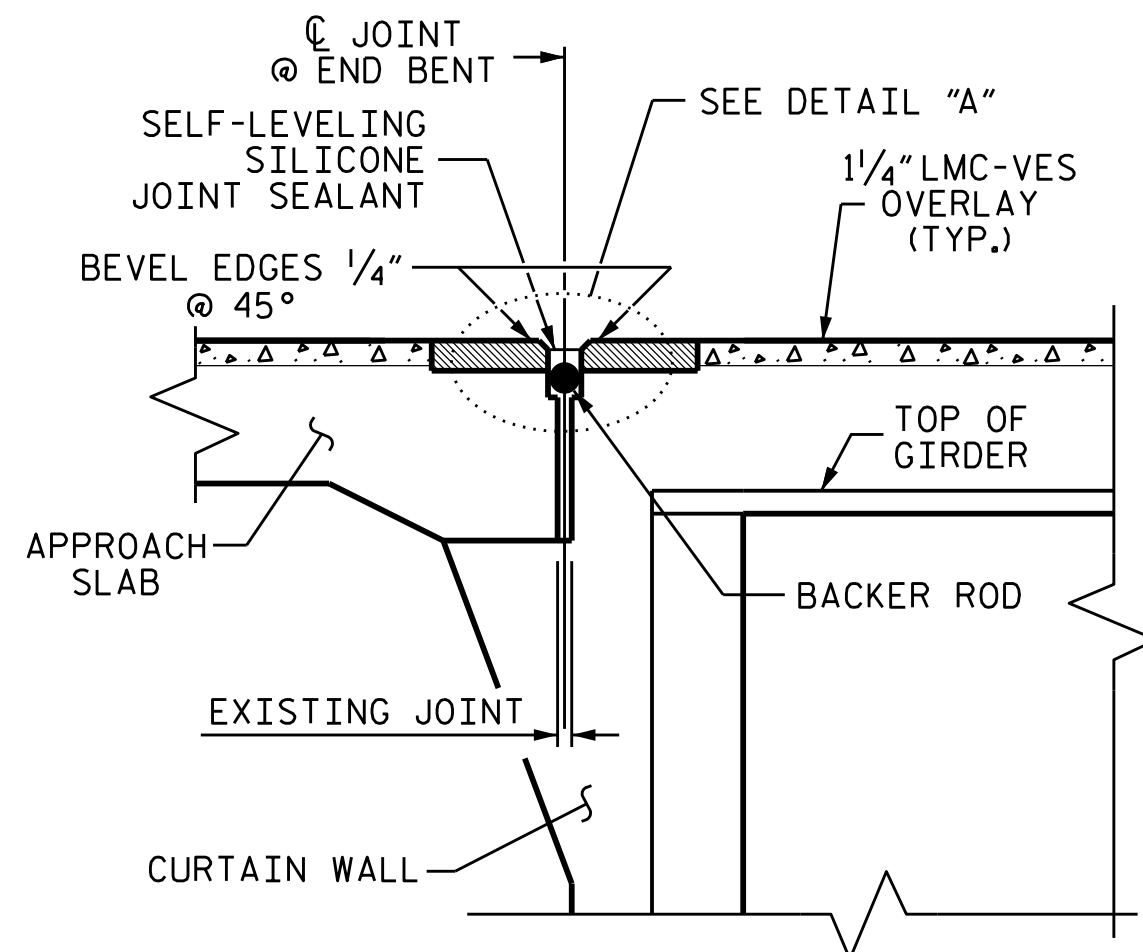

PROPOSED SILICONE JOINT SEALANT

NOTE
 THE CONTRACTOR SHALL FIELD VERIFY THE EXISTING JOINT OPENING PRIOR TO ORDERING JOINT SEAL MATERIAL. IF ACTUAL JOINT OPENING VARIES FROM THE OPENING INDICATED IN DETAIL BY MORE THAN 1/4", NOTIFY ENGINEER. REVISION TO THE JOINT SEAL SIZE MIGHT BE NECESSARY.

FINAL JOINT SEALS SHALL NOT BE INSTALLED UNTIL THE LMC-VES OVERLAY IS COMPLETE.

THE CONTRACTOR SHALL TAKE CARE DURING JOINT REHAB OPERATIONS NOT TO DROP ANY MATERIAL BELOW THE BRIDGE WITHOUT PROTECTIVE DEVICES BELOW TO CATCH THE MATERIAL. ANY MATERIAL THAT FALLS BELOW THE BRIDGE SHALL BE CONTAINED, REMOVED AND DISPOSED OF BY THE CONTRACTOR AT NO EXTRA COST TO THE DEPARTMENT. IF THE ENGINEER DETERMINES THAT THE PROTECTIVE DEVICES ARE NOT ADEQUATE OR NOT BEING ADEQUATE, THE WORK SHALL BE SUSPENDED UNTIL ADEQUATE PROTECTION IS PROVIDED.

THE CONTRACTOR WILL NOT BE PERMITTED TO FORM THE JOINTS IN LIEU OF SAWING THE JOINT.

DURING THE JOINT INSTALLATION PROCEDURE, THE JOINT AND SURROUNDING AREA SHALL BE KEPT CLEAN AND FREE OF DEBRIS.

THE MANUFACTURER IS TO PROVIDE THE NOMINAL UNCOMPRESSED SEAL WIDTH OF THE BACKER ROD FOR THE EXISTING JOINT SIZE AND ACCOMMODATE THE MINIMUM EXPANSION SHOWN ON THE PLANS.

A MANUFACTURER'S CERTIFIED TRAINED REPRESENTATIVE SHALL BE PRESENT DURING THE INSTALLATION OF THE FIRST JOINT OF THE PROJECT, OR UNTIL THE ENGINEER IS SATISFIED WITH THE INSTALLATION PROCESS.

THE INSTALLATION OF THE FOAM JOINT SEAL SHALL BE WATERTIGHT.

FINAL SURFACE OF THE JOINT DEMOLITION AREA PRIOR TO PLACEMENT OF CONCRETE REPAIR MATERIAL OR ELASTOMERIC CONCRETE SHOULD BE REASONABLY FLAT AND LEVEL. ENGINEER SHALL DETERMINE THE ACCEPTABILITY OF THE SURFACE PRIOR TO PLACEMENT OF REPAIR CONCRETE OR ELASTOMERIC CONCRETE.

FOR ELASTOMERIC CONCRETE FOR PRESERVATION, SEE SPECIAL PROVISIONS.

FOR POURABLE SILICONE JOINT SEALANT, SEE SPECIAL PROVISIONS.

FOR FOAM JOINT SEAL FOR PRESERVATION, SEE SPECIAL PROVISIONS.

SECTION A-A

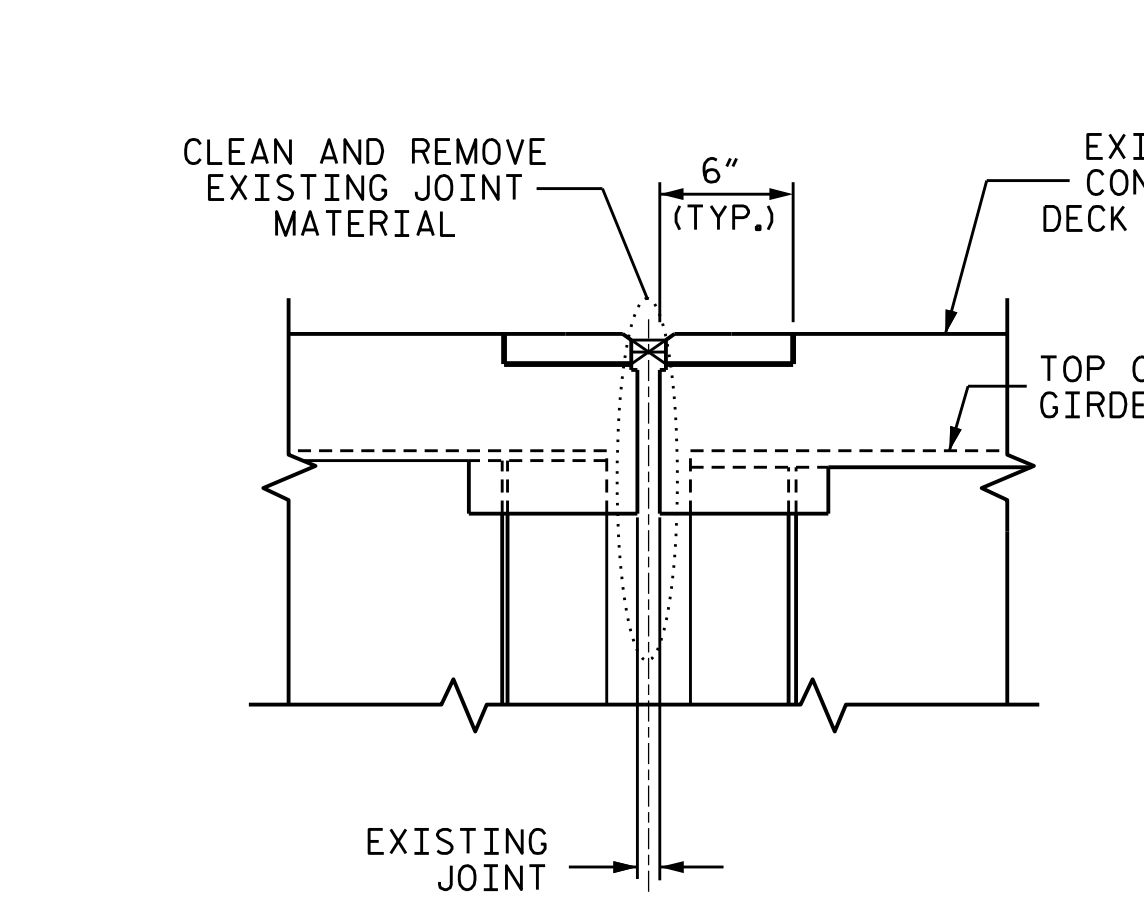

EXISTING JOINT

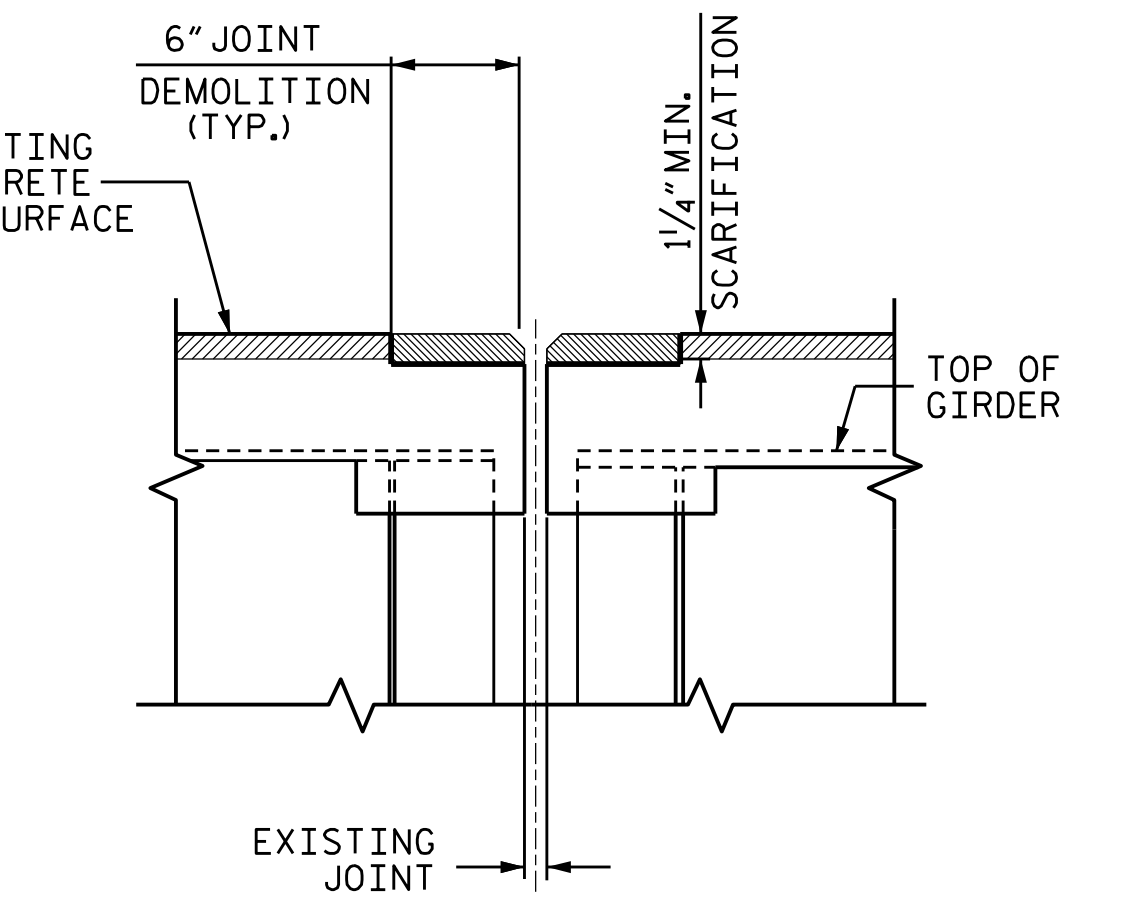

MINIMUM EXISTING JOINT DEMOLITION & SCARIFICATION

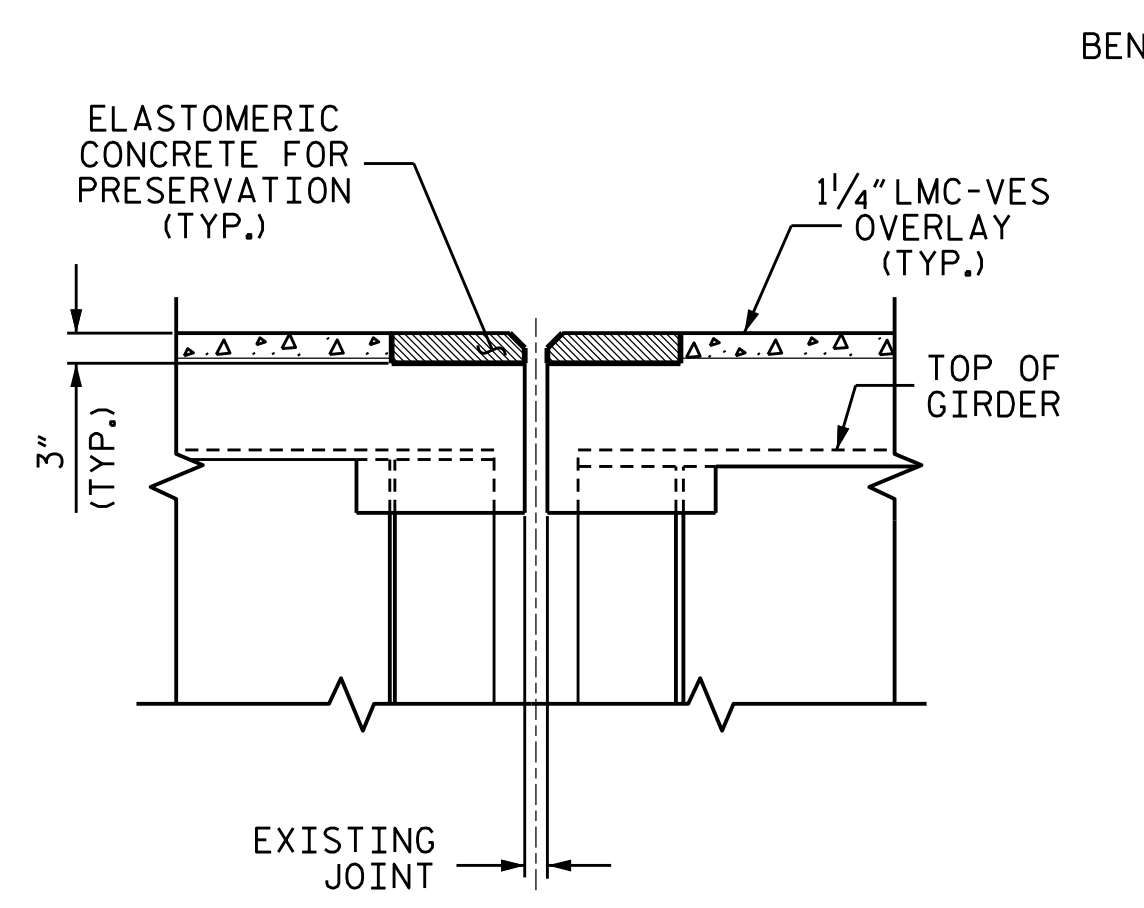

PROPOSED PRE-SAWED JOINT

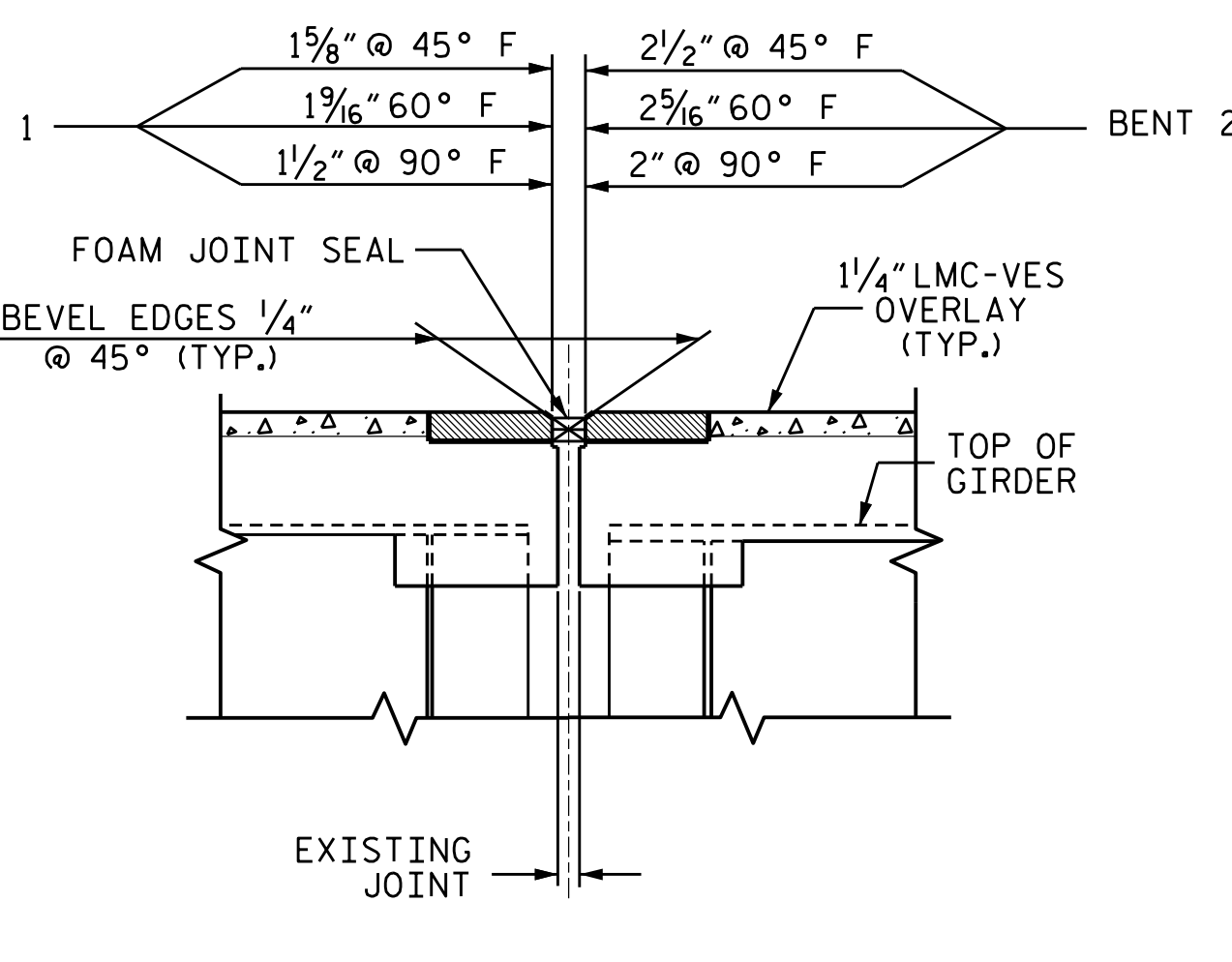

PROPOSED FOAM JOINT SEAL

SECTION B-B

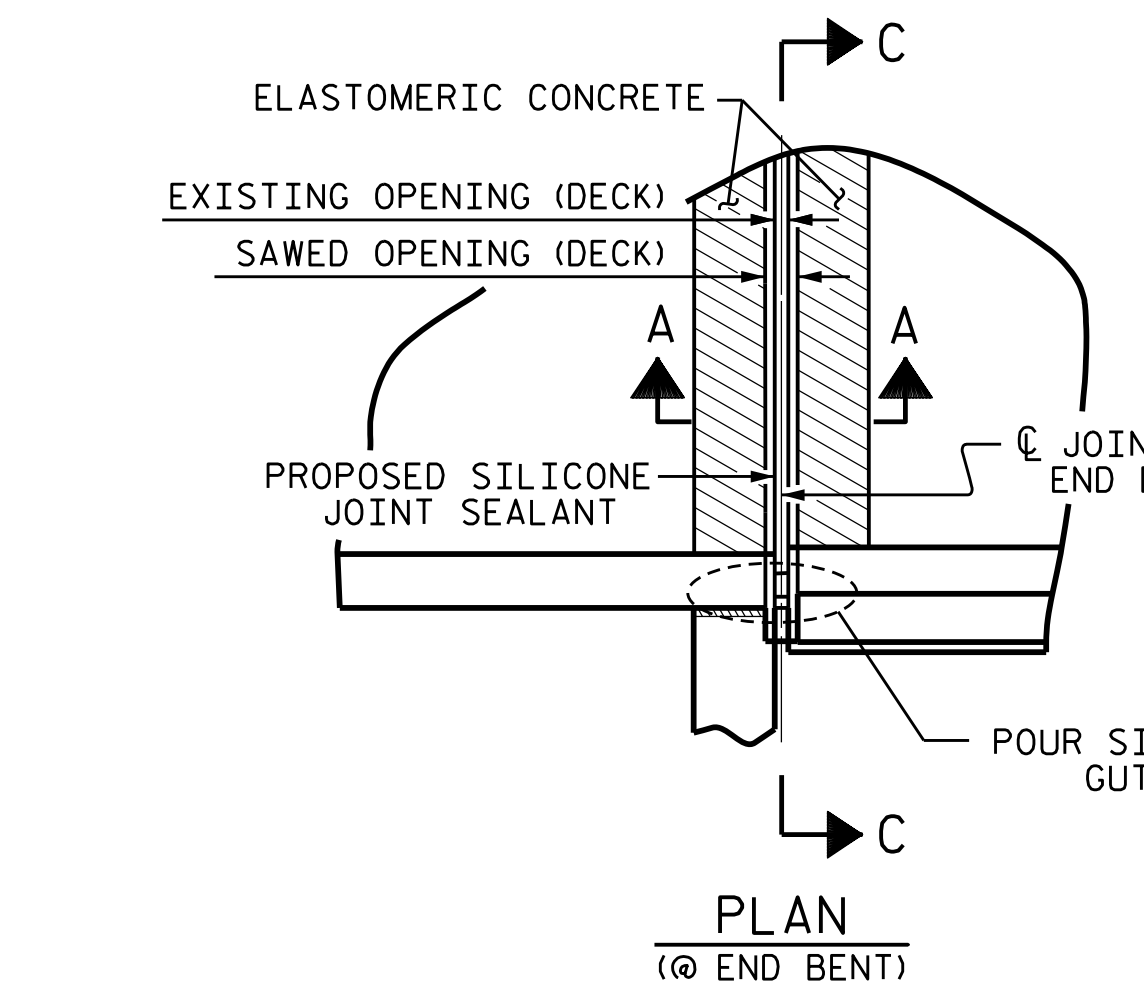

PLAN (@ END BENT)

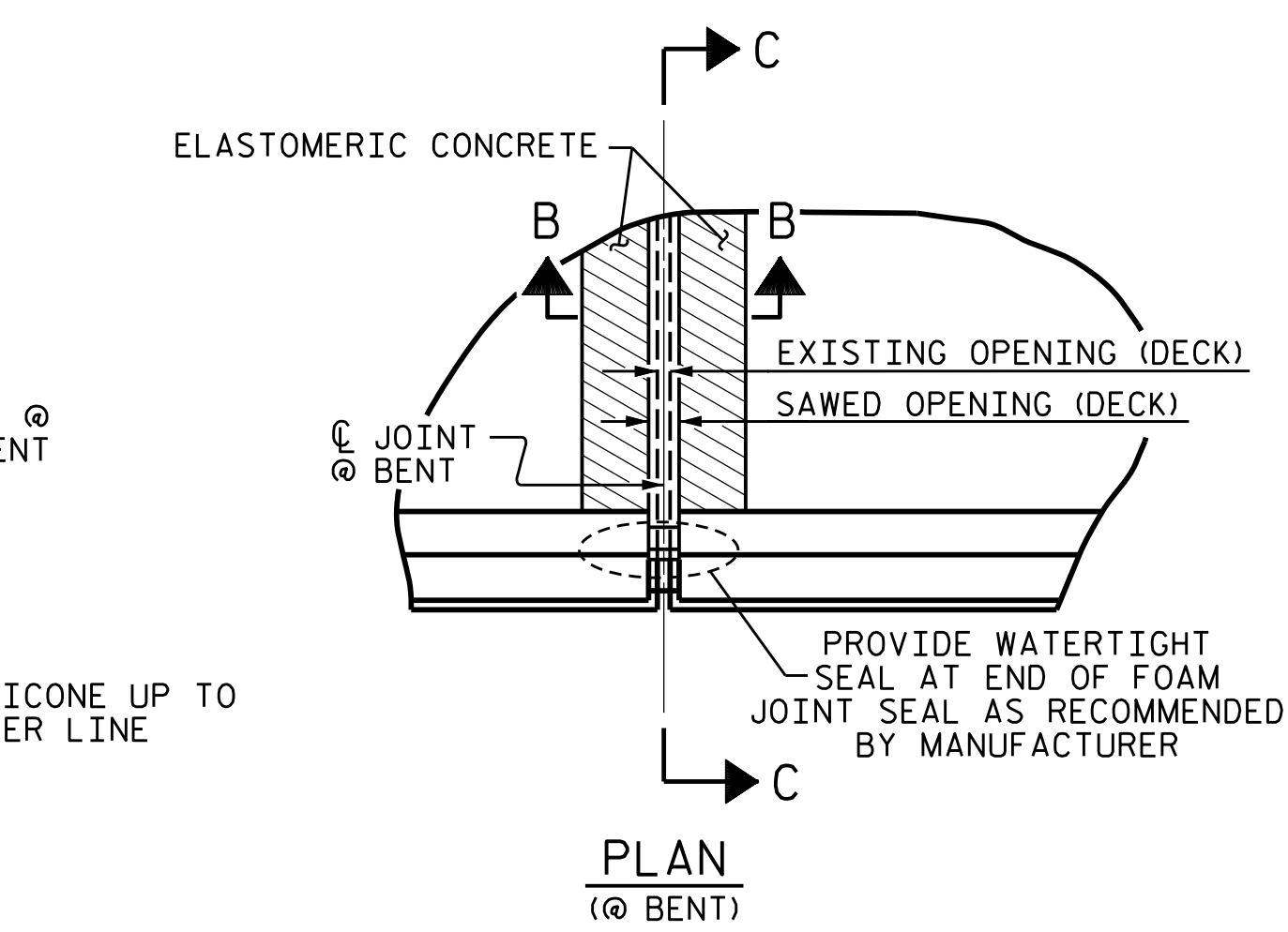

PLAN (@ BENT)

JOINT SEAL DETAILS

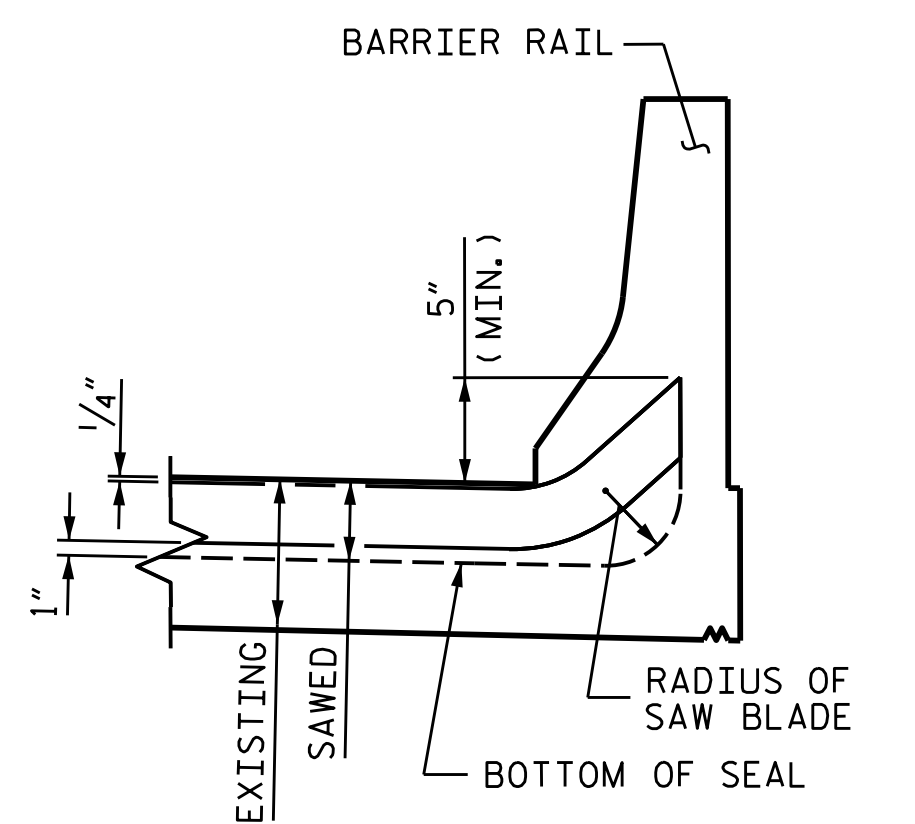

SECTION C-C

| JOINT REPAIR QUANTITY TABLE | | | |
|-----------------------------|-------------------------|-----------------------------------|---------------------------------------|
| | BRIDGE JOINT DEMOLITION | FOAM JOINT SEALS FOR PRESERVATION | ELASTOMERIC CONCRETE FOR PRESERVATION |
| BENT 1 | 70.8 SQ. FT. | 70.8 LF | 17.7 CU. FT. |
| BENT 2 | 61.2 SQ. FT. | 61.2 LF | 15.3 CU. FT. |
| * TOTAL | 132.0 SQ. FT. | 132.0 LF | 33.0 CU. FT. |

* BASED ON THE MINIMUM BLOCKOUT SHOWN.

| JOINT REPAIR QUANTITY TABLE | | | |
|-----------------------------|-------------------------|---------------------------------|---------------------------------------|
| | BRIDGE JOINT DEMOLITION | POURABLE SILICONE JOINT SEALANT | ELASTOMERIC CONCRETE FOR PRESERVATION |
| END BENT 1 | 76.7 SQ. FT. | 76.7 LF | 18.7 CU. FT. |
| END BENT 2 | 59.6 SQ. FT. | 59.6 LF | 14.9 CU. FT. |
| * TOTAL | 136.3 SQ. FT. | 136.3 LF | 33.6 CU. FT. |

* BASED ON THE MINIMUM BLOCKOUT SHOWN.

PROJECT NO. 15BPR.51
 GASTON COUNTY
 BRIDGE NO. 350314



STATE OF NORTH CAROLINA
 DEPARTMENT OF TRANSPORTATION
 RALEIGH

JOINT DETAILS

DRAWN BY : GHOLAMREZA KOUCHEKI DATE : 12/2021
 CHECKED BY : H. A. LOCKLEAR DATE : 12/2021

| REVISIONS | | | | | | SHEET NO. S2-11 |
|-----------|-----|-------|-----|-----|-------|--------------------|
| NO. | BY: | DATE: | NO. | BY: | DATE: | |
| 1 | | | 3 | | | TOTAL SHEETS 67 |
| 2 | | | 4 | | | |

DOCUMENT NOT CONSIDERED FINAL UNLESS ALL SIGNATURES COMPLETED