

NOTE:
PLACE TEMPORARY ROCK SEDIMENT DAMS TYPE - B
AND TEMPORARY ROCK SILT CHECKS TYPE - A AT
DRAINAGE OUTLETS.

CLEARING AND GRUBBING
EROSION CONTROL FOR
CONSTRUCTION SHEET 4

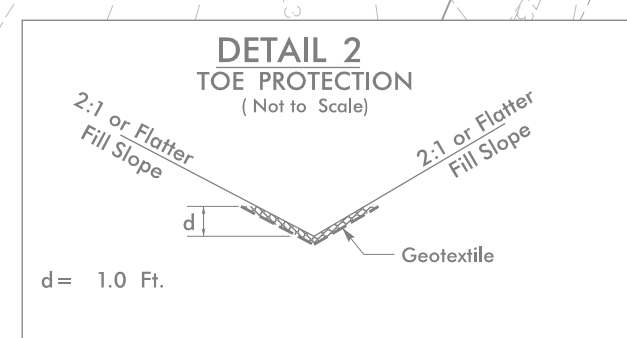
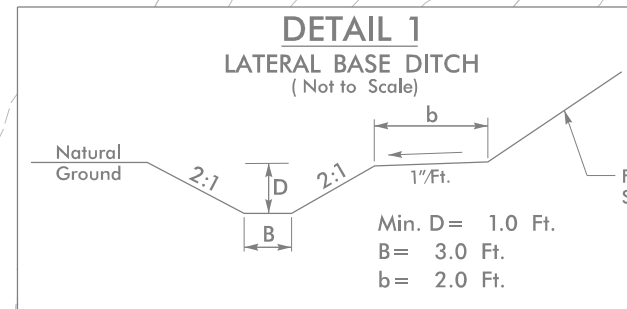

Y2 - CURVE DATA
PI Sta 12+03.89
 $\Delta = 18' 43' 58.8''$ (LT)
D = 14' 37' 30.8"
L = 128.05'
T = 64.03'
R = 391.76'
SE = 0.02

Y1 - CURVE DATA
PI Sta 13+22.38
 $\Delta = 12' 58' 38.8''$ (LT)
D = 50' 48' 46.7"
L = 170.20'
T = 85.83'
R = 533.00'
SE = 0.03

Y2 - CURVE DATA
PI Sta 12+87.95
 $\Delta = 22' 50' 52.6''$ (LT)
D = 15' 26' 37.0"
L = 147.94'
T = 74.97'
R = 371.00'

McDowell County
Bridge #580084

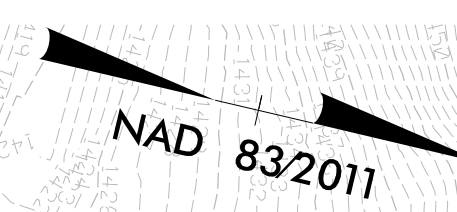

| | |
|--|---------------------------|
| PROJECT REFERENCE NO. BR-0033 | SHEET NO. EC-4/CONST.4 |
| RW SHEET NO. ROADWAY DESIGN ENGINEER | HYDRAULICS ENGINEER |
| <p>TGS ENGINEERS 706 HILLSBOROUGH STREET SUITE 200 RALEIGH, NC 27603 PH (919) 773-8887 CORP. LICENSE NO.: C-0275</p> | |

-L- CURVE DATA
PI Sta 11+84.16
 $\Delta = 18' 17' 46.1''$ (RT)
D = 10' 44' 58.8"
L = 170.20'
T = 85.83'
R = 533.00'
SE = 0.03
RUNOFF = 60'

PI Sta 13+54.36
 $\Delta = 18' 17' 46.1''$ (LT)
D = 10' 44' 58.8"
L = 170.20'
T = 85.83'
R = 533.00'
SE = 0.03
RUNOFF = 60'

BEGIN TIP PROJECT BR-0033
-L- STA. 10+30.00

BEGIN CONSTRUCTION
-L- STA. 9+70.00

-L- POT Sta. 9+00.00

CATAWBA RIVER
DRIVEWAY
-L- PC Sta. 10+98.33

-Y2- POT Sta. 13+92.71
-L- POC STA. 11+76.23
-L- PRC Sta. 12+68.53
-RPD- POT Sta. 10+00.00
-RPC- POT Sta. 13+87.43
-L- POC STA. 13+38.35

-RPD- PC Sta. 11+06.49
END CONSTRUCTION
-RPD- STA. 11+90.00

2
SH&H ENTERPRISES, LLC

-RPD- PT Sta. 14+42.64

1
CYNTHIA ELLEN SUGG

BEGIN CONSTRUCTION
-Y2- STA. 11+25.00

-Y2- PC Sta. 11+39.29
-Y2- PCC Sta. 12+67.34

-Y2- PT Sta. 13+74.37

RESET EXISTING FENCE

50' TAPER
LT. & RT.
+80.00

CLASS 'B' RIP RAP
EST. 3 TONS
GEOTEXTILE
EST. 11 SY

120' MEDIAN TAPER

40' R
4' PS

40' R
4' PS

40' R
4' PS

40' R
4' PS

40' R
4' PS

40' R
4' PS

40' R
4' PS

40' R
4' PS

40' R
4' PS

40' R
4' PS

40' R
4' PS

40' R
4' PS

40' R
4' PS

40' R
4' PS

40' R
4' PS

40' R
4' PS

40' R
4' PS

FROM -L- STA. 10+50 TO STA. 11+50 LT
-RPC- POT Sta. 10+00.00
-Y2- POT Sta. 10+00.00

FROM -L- STA. 12+33 TO STA. 12+92 RT
Type of Liner = Class 'B' Rip-Rap

FROM -L- STA. 10+50 TO STA. 11+50 LT
-RPC- POT Sta. 10+00.00
-Y2- POT Sta. 10+00.00

1
CYNTHIA ELLEN SUGG

BEGIN CONSTRUCTION
-Y2- STA. 11+25.00

-Y2- PC Sta. 11+39.29
-Y2- PCC Sta. 12+67.34

-Y2- PT Sta. 13+74.37

RESET EXISTING FENCE

50' TAPER
LT. & RT.
+80.00

CLASS 'B' RIP RAP
EST. 3 TONS
GEOTEXTILE
EST. 11 SY

120' MEDIAN TAPER

40' R
4' PS

40' R
4' PS

40' R
4' PS

40' R
4' PS

40' R
4' PS

40' R
4' PS

40' R
4' PS

40' R
4' PS

40' R
4' PS

40' R
4' PS

40' R
4' PS

40' R
4' PS

40' R
4' PS

40' R
4' PS

40' R
4' PS

40' R
4' PS

40' R
4' PS

BEGIN CONSTRUCTION
-RPC- POT Sta. 11+90.00

-RPC- PC Sta. 12+2.98

-RPC- PT Sta. 13+60.92

BEGIN BRIDGE
-L- STA. 15+15.26

REMOVE EXISTING BRIDGE

END BRIDGE
-L- STA. 17+24.26

BEGIN APPROACH CAT-1
-L- STA. 15+01.29

END APPROACH
-L- STA. 17+38.24

-L- POT Sta. 16+11.51
-140- POT Sta. 19+16.80

END CONSTRUCTION
-140- STA. 22+10.00

-L- PT Sta. 14+38.75

-L- POT Sta. 16+11.51
-140- POT Sta. 19+16.80

END CONSTRUCTION
-140- STA. 22+10.00

-L- PT Sta. 14+38.75

-L- POT Sta. 16+11.51
-140- POT Sta. 19+16.80

END CONSTRUCTION
-140- STA. 22+10.00

-L- PT Sta. 14+38.75

-L- POT Sta. 16+11.51
-140- POT Sta. 19+16.80

END CONSTRUCTION
-140- STA. 22+10.00

-L- PT Sta. 14+38.75

-L- POT Sta. 16+11.51
-140- POT Sta. 19+16.80

END CONSTRUCTION
-140- STA. 22+10.00

-L- PT Sta. 14+38.75

-Y1- PC Sta. 10+50.15

-Y1- PT Sta. 12+69.80

BEGIN CONSTRUCTION
-Y1- STA. 13+00.00

END TIP PROJECT BR-0033
-L- POT STA. 18+54.66
-Y1- POT STA. 14+40.79

END CONSTRUCTION
-Y1- STA. 15+04.53

-Y1- PC Sta. 15+11.27

-Y1- PT Sta. 17+66.71

-Y1- POT Sta. 16+11.51
-140- POT Sta. 19+16.80

END CONSTRUCTION
-140- STA. 22+10.00

-L- PT Sta. 14+38.75

-L- POT Sta. 16+11.51
-140- POT Sta. 19+16.80

END CONSTRUCTION
-140- STA. 22+10.00

-L- PT Sta. 14+38.75

-L- POT Sta. 16+11.51
-140- POT Sta. 19+16.80

END CONSTRUCTION
-140- STA. 22+10.00

-L- PT Sta. 14+38.75

-L- POT Sta. 16+11.51
-140- POT Sta. 19+16.80

END CONSTRUCTION
-140- STA. 22+10.00

-L- PT Sta. 14+38.75

-L- POT Sta. 16+11.51
-140- POT Sta. 19+16.80

END CONSTRUCTION
-140- STA. 22+10.00

-L- PT Sta. 14+38.75

-L- POT Sta. 16+11.51
-140- POT Sta. 19+16.80

END CONSTRUCTION
-140- STA. 22+10.00

-L- PT Sta. 14+38.75

-L- POT Sta. 16+11.51
-140- POT Sta. 19+16.80

END CONSTRUCTION
-140- STA. 22+10.00

-L- PT Sta. 14+38.75

-L- POT Sta. 16+11.51
-140- POT Sta. 19+16.80

END CONSTRUCTION
-140- STA. 22+10.00

-L- PT Sta. 14+38.75

-L- POT Sta. 16+11.51
-140- POT Sta. 19+16.80

END CONSTRUCTION
-140- STA. 22+10.00

-L- PT Sta. 14+38.75

-L- POT Sta. 16+11.51
-140- POT Sta. 19+16.80

END CONSTRUCTION
-140- STA. 22+10.00

-L- PT Sta. 14+38.75

-L- POT Sta. 16+11.51
-140- POT Sta. 19+16.80

END CONSTRUCTION
-140- STA. 22+10.00

-L- PT Sta. 14+38.75

-L- POT Sta. 16+11.51
-140- POT Sta. 19+16.80

END CONSTRUCTION
-140- STA. 22+10.00

-L- PT Sta. 14+38.75

-L- POT Sta. 16+11.51
-140- POT Sta. 19+16.80

END CONSTRUCTION
-140- STA. 22+10.00

-L- PT Sta. 14+38.75

-L- POT Sta. 16+11.51
-140- POT Sta. 19+16.80

END CONSTRUCTION
-140- STA. 22+10.00

-L- PT Sta. 14+38.75

-L- POT Sta. 16+11.51
-140- POT Sta. 19+16.80

END CONSTRUCTION
-140- STA. 22+10.00

-L- PT Sta. 14+38.75

-L- POT Sta. 16+11.51
-140- POT Sta. 19+16.80

END CONSTRUCTION
-140- STA. 22+10.00

-L- PT Sta. 14+38.75

-L- POT Sta. 16+11.51
-140- POT Sta. 19+16.80

END CONSTRUCTION
-140- STA. 22+10.00

-L- PT Sta. 14+38.75

-L- POT Sta. 16+11.51
-140- POT Sta. 19+16.80

END CONSTRUCTION
-140- STA. 22+10.00

-L- PT Sta. 14+38.75

-L- POT Sta. 16+11.51
-140- POT Sta. 19+16.80

END CONSTRUCTION
-140- STA. 22+10.00

-L- PT Sta. 14+38.75

-L- POT Sta. 16+11.51
-140- POT Sta. 19+16.80

END CONSTRUCTION
-140- STA. 22+10.00

-L- PT Sta. 14+38.75

-L- POT Sta. 16+11.51
-140- POT Sta. 19+16.80

END CONSTRUCTION
-140- STA. 22+10.00

-L- PT Sta. 14+38.75

-L- POT Sta. 16+11.51
-140- POT Sta. 19+16.80

END CONSTRUCTION
-140- STA. 22+10.00

-L- PT Sta. 14+38.75

-L- POT Sta. 16+11.51
-140- POT Sta. 19+16.80

END CONSTRUCTION
-140- STA. 22+10.00

-L- PT Sta. 14+38.75

-L- POT Sta. 16+11.51
-140- POT Sta. 19+16.80

END CONSTRUCTION
-140- STA. 22+10.00

-L- PT Sta. 14+38.75

-L- POT Sta. 16+11.51
-140- POT Sta. 19+16.80

END CONSTRUCTION
-140- STA. 22+10.00

-L- PT Sta. 14+38.75

-L- POT Sta. 16+11.51
-140- POT Sta. 19+16.80

END CONSTRUCTION
-140- STA. 22+10.00

-L- PT Sta. 14+38.75

-L- POT Sta. 16+11.51
-140- POT Sta. 19+16.80

END CONSTRUCTION
-140- STA. 22+10.00

-L- PT Sta. 14+38.75

-L- POT Sta. 16+11.51
-140- POT Sta. 19+16.80

END CONSTRUCTION
-140- STA. 22+10.00

-L- PT Sta. 14+38.75

-L- POT Sta. 16+11.51
-140- POT Sta. 19+16.80

END CONSTRUCTION
-140- STA. 22+10.00

-L- PT Sta. 14+38.75

-L- POT Sta. 16+11.51
-140- POT Sta. 19+16.80

END CONSTRUCTION
-140- STA. 22+10.00

-L- PT Sta. 14+38.75

-L- POT Sta. 16+11.51
-140- POT Sta. 19+16.80

END CONSTRUCTION
-140- STA. 22+10.00

-L- PT Sta. 14+38.75

-L- POT Sta. 16+11.51
-140- POT Sta. 19+16.80

END CONSTRUCTION
-140- STA. 22+10.00

-L- PT Sta. 14+38.75

-L- POT Sta. 16+11.51
-140- POT Sta. 19+16.80

END CONSTRUCTION
-140- STA. 22+10.00