

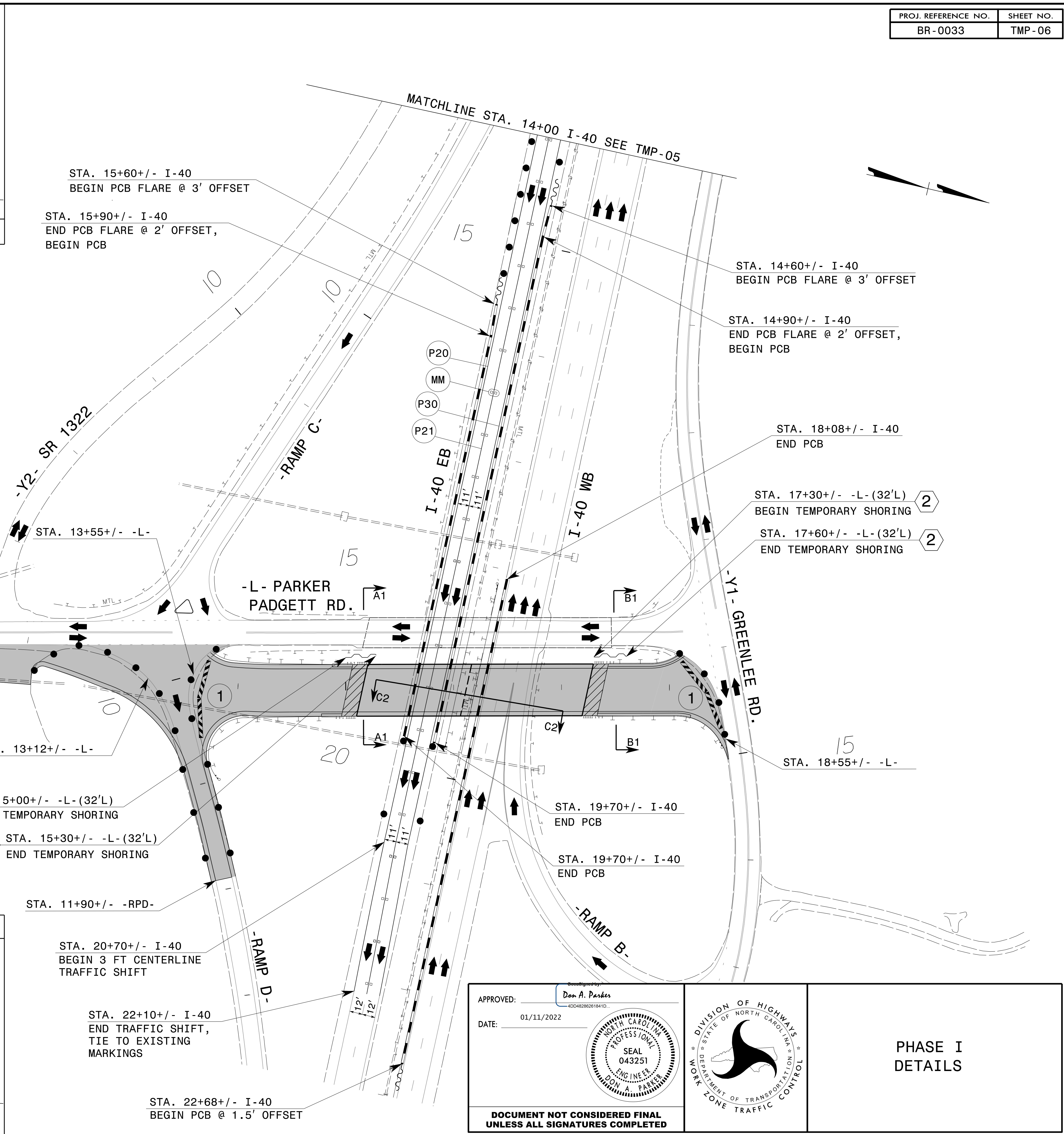

Shoring I.D. No.	Estimated Average Height (ft.)	Quantity (sq. ft.)
①	13 FT.	390 SQ. FT.
②	15 FT.	450 SQ. FT.

REFER TO TMP-07 FOR SECTION C2-C2

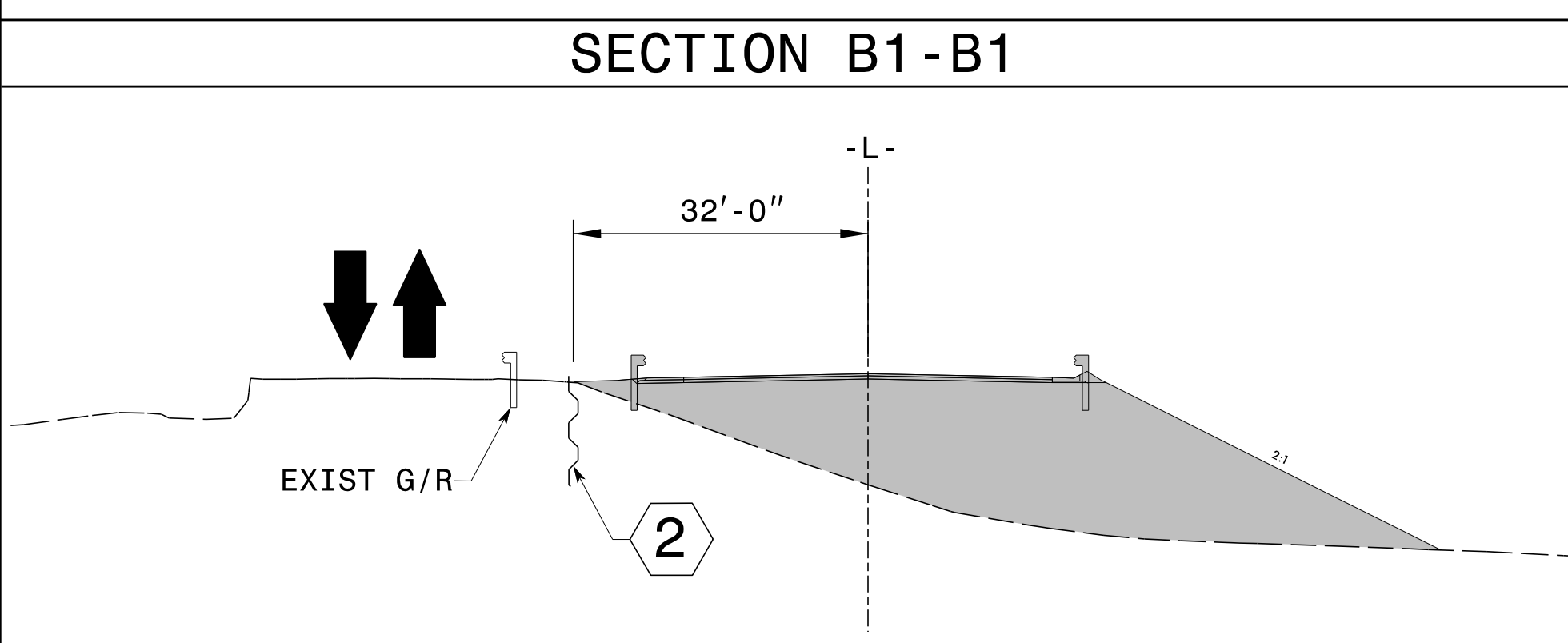
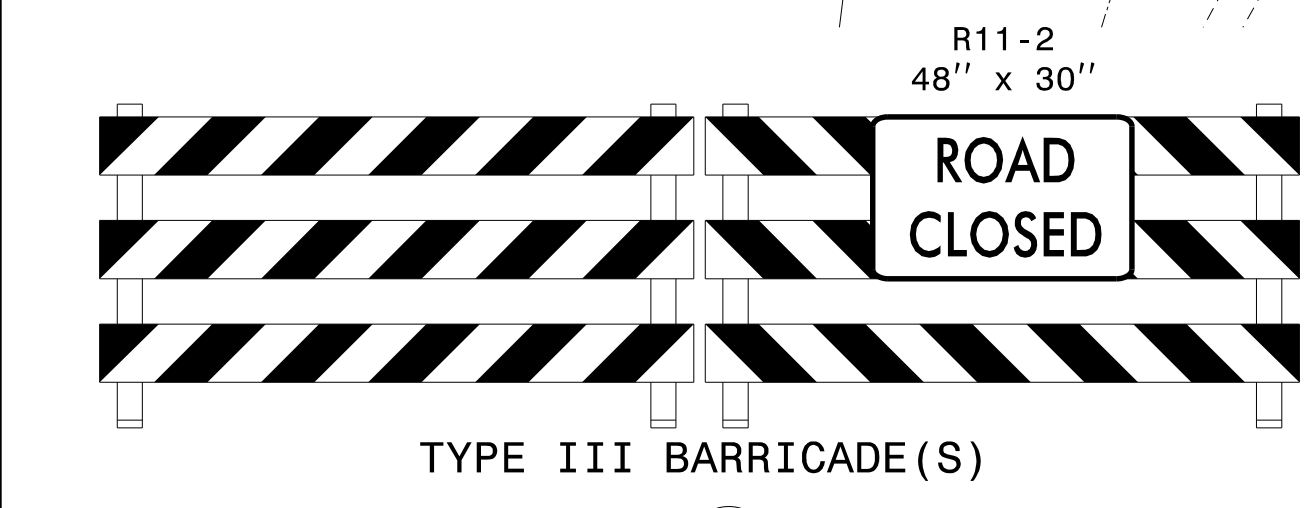
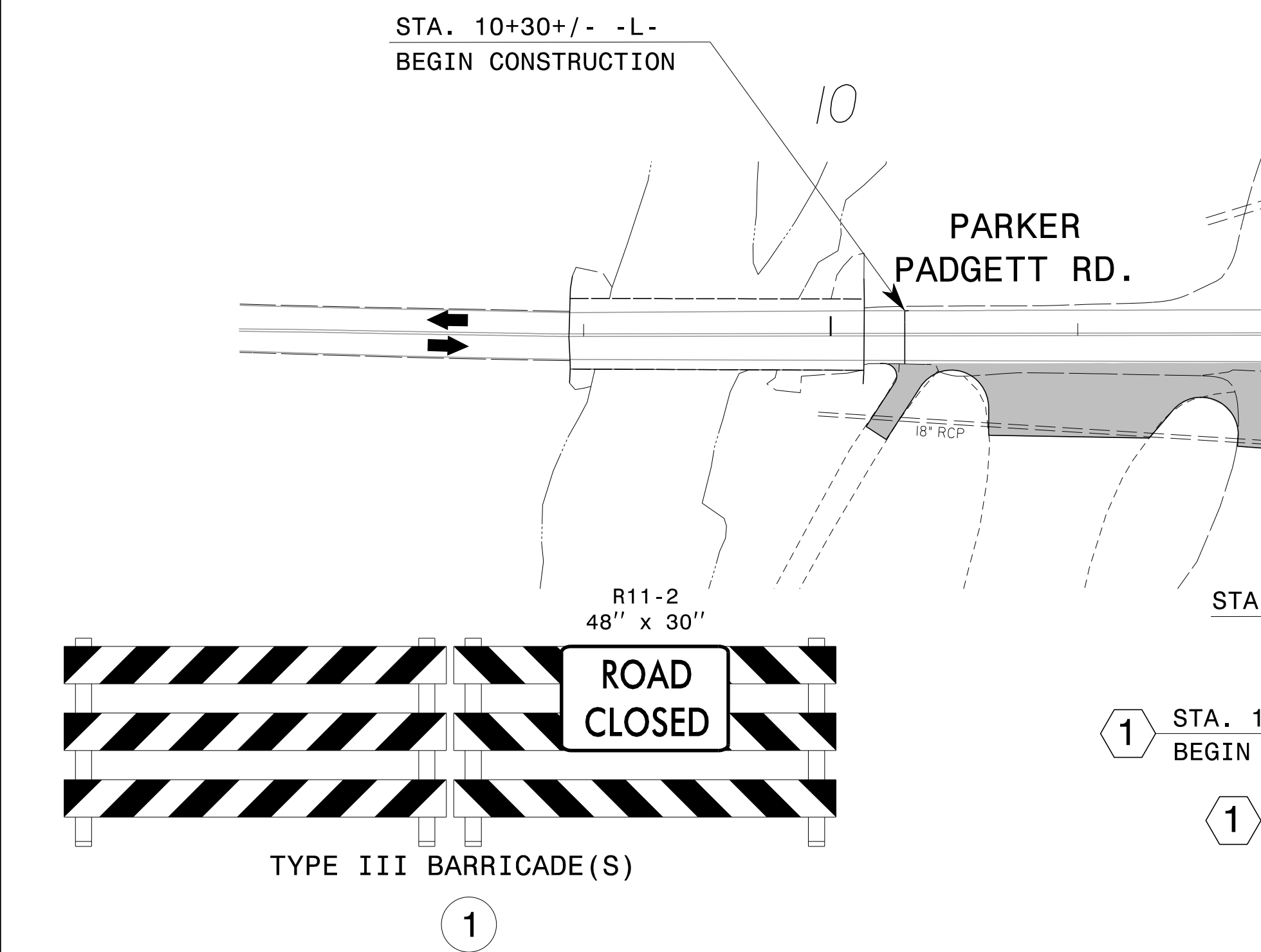
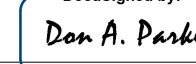

APPROVED: 
 DATE: 01/11/2022



**DOCUMENT NOT CONSIDERED FINAL
UNLESS ALL SIGNATURES COMPLETED**



**PHASE I
DETAILS**

I:\10\2022
 N:\Special\BR0033\TrafficControl\TCP\90%_BR-0033\BR-0033.TC_TMP_06.dgn
 User:tmackillu