

NOTES:

▲ FOR EACH BEAM BEING REPAIRED, CONTRACTOR SHALL FIELD VERIFY DIMENSIONS. PLATE DIMENSIONS SHALL BE ADJUSTED TO FIT IN THE SPACE FROM BEAM END TO 1/2" FROM STIFFENER / CONNECTOR PLATE.

THE ENGINEER SHALL BE NOTIFIED IF DIMENSION "B" EXCEEDS 12". IF SO, AN ADDITIONAL COLUMN OF BOLTS SHALL BE ADDED.

THE PLATES FOR DIM "E" SHALL BE PLACED SNUG TO THE BOTTOM OF THE DIAPHRAGM.

DIMENSION "Y" SHALL BE A MINIMUM OF 3/4" AND A MAXIMUM OF 6".

EACH PLATE SHALL BE APPROXIMATELY ONE-HALF THE ORIGINAL THICKNESS OF THE BEAM WEB, 3/16" MINIMUM, AND SHALL BE APPROVED BY THE ENGINEER.

PLATES SHALL BE SHOP PRIMED PRIOR TO DELIVERY.

PLATES SHALL BE NEW, AND SHALL BE THE SAME GRADE OF THE EXISTING STEEL MEMBER OR BETTER.

ALL BOLTS SHALL MEET ASTM A325.

ALL NUTS SHALL MEET ASTM A194.

ALL FLAT WASHERS SHALL MEET ASTM F436.

IF STEEL IS WEATHER, ALL BOLTS, NUT, AND WASHERS SHALL BE AASHTO M163 TYPE 3.

THE EPOXY MASTIC USED FOR THIS WORK SHALL BE COMPATIBLE WITH THE PAINT SYSTEM USED FOR THE PAINTING OF EXISTING STEEL AND SHALL BE APPROVED BY THE NCDOT MATERIALS AND TEST UNIT. THE EPOXY MASTIC WILL BE ACCEPTED ON THE BASIS OF THE MANUFACTURER'S WRITTEN CERTIFICATION THAT THE BATCH PRODUCED MEETS THEIR PRODUCT SPECIFICATION.

REPAIR SEQUENCE:

REMOVE LIVE LOAD FROM REPAIR AREA BY EITHER CLOSING BRIDGE TO TRAFFIC OR SHIFTING TRAFFIC AWAY FROM REPAIR AREA.

IF PAINTING THE STEEL, CLEAN AND BLAST STEEL AS REQUIRED, PRIOR TO PERFORMING STEEL REPAIRS. OTHERWISE, MECHANICALLY CLEAN RUST, SCALE, AND EXISTING PAINT TO AT LEAST 3" BEYOND REPAIR AREA.

PRIME ENTIRE REPAIR AREA AND REPAIR PLATES WITH AN ORGANIC ZINC PRIMER PRIOR TO ATTACHING NEW PLATES

ONE PLATE SHALL BE PLACED, ON EACH SIDE OF THE BEAM ENDS.

PRIOR TO PLACEMENT OF THE PLATES, APPLY WET EPOXY MASTIC AROUND THE TOP AND SIDE PERIMETERS ON THE PLATE FACE THAT IS TO BE IN CONTACT WITH THE BEAM. AMOUNT OF EPOXY MASTIC SHALL BE SUFFICIENT TO SEAL THE INTERFACE OF THE PLATE AND THE BEAM AFTER BOLTS ARE TIGHTENED. NO EPOXY MASTIC SHALL BE PLACED ALONG THE BOTTOM PERIMETER ON THE PLATE. WHILE THE MASTIC IS STILL WET, PLATES SHALL BE PUT IN PLACE AND BOLTS PROPERLY TIGHTENED.

TENSION ON THE BOLTS SHALL BE CALIBRATED USING DIRECT TENSION INDICATOR WASHERS (DTIS) IN ACCORDANCE WITH ARTICLE 440-8 OF THE NCDOT STANDARD SPECIFICATIONS. DTIS SHALL BE MEET ASTM F959.

AFTER PLACEMENT OF THE PLATES AND TIGHTENING OF THE BOLTS, PLATES, BOLTS, AND SURROUNDING AREA SHALL BE PAINTED OR PAINT SHALL BE REPAIRED AS PER PROJECT REQUIREMENTS AND NCDOT STANDARD SPECIFICATIONS.

PAYMENT WILL BE MADE AT CONTRACT PRICE BID PER POUNDS STRUCTURAL STEEL USED FOR GIRDER REPAIR. SUCH PAYMENTS WILL BE FULL COMPENSATION FOR ALL MATERIALS, EQUIPMENT, TOOLS, LABOR, MISCELLANEOUS STEEL, AND INCIDENTALS NECESSARY TO COMPLETE THE WORK.

PROJECT NO. 15BPR.55
 FORSYTH COUNTY
 BRIDGE NO. 330078

SHEET 2 OF 3

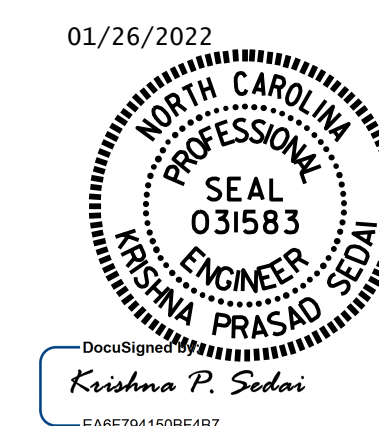

STATE OF NORTH CAROLINA
 DEPARTMENT OF TRANSPORTATION
 RALEIGH

BEAM PLATING REPAIR DETAILS

REVISIONS						SHEET NO.
NO.	BY:	DATE:	NO.	BY:	DATE:	S-73
1			3			TOTAL SHEETS 79
2			4			

DOCUMENT NOT CONSIDERED FINAL UNLESS ALL SIGNATURES COMPLETED

DRAWN BY : C.L. BRIGHT DATE : 9/2018
 CHECKED BY : T. M. SHERRILL DATE : 9/2018

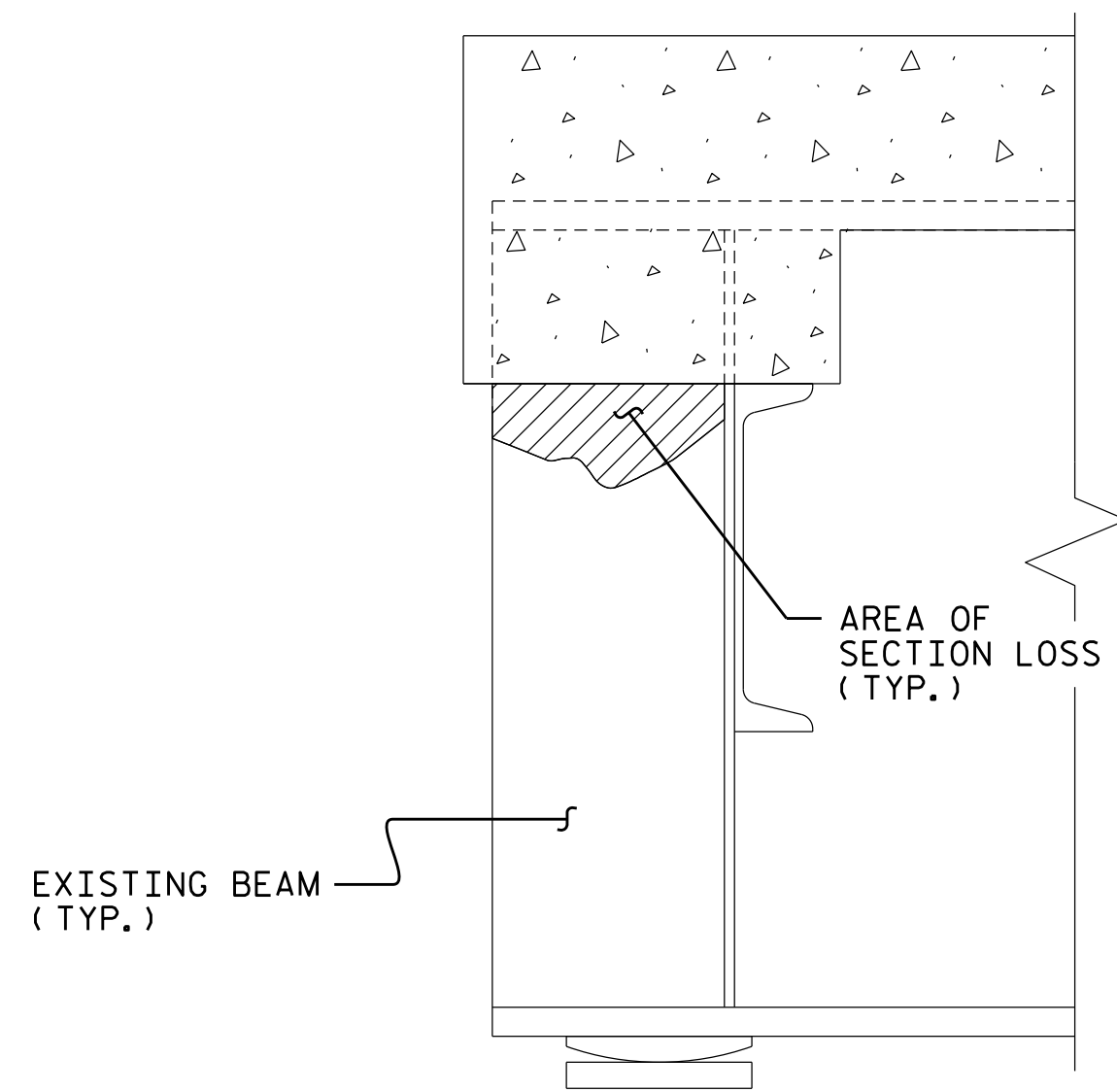

BEAM END SECTION LOSS
 (EXISTING)

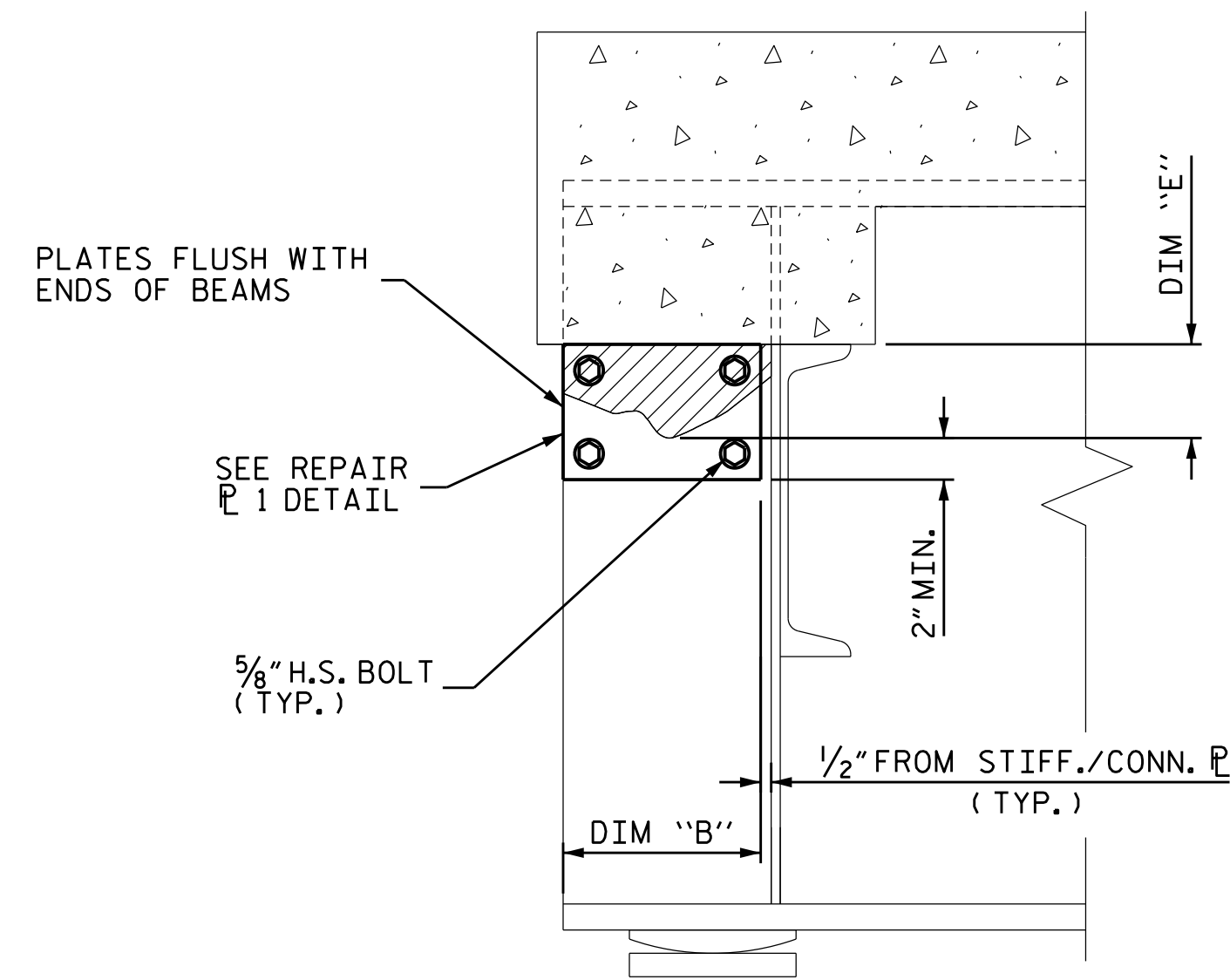

BEAM END SECTION LOSS PLATING REPAIR
 (DIMENSION "E" 3" TO 6 1/2" USE REPAIR P 1)

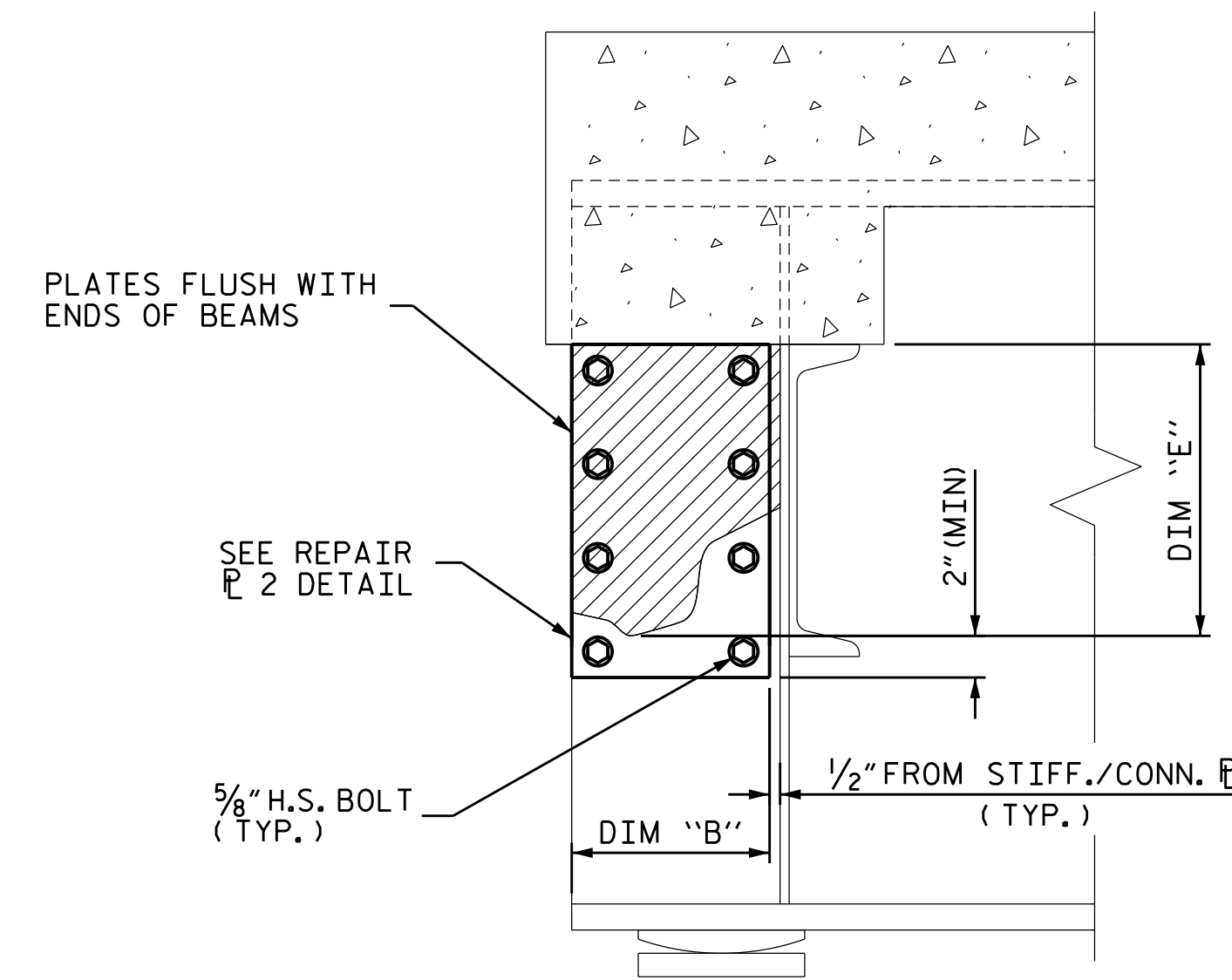

BEAM END SECTION LOSS PLATING REPAIR
 (DIMENSION "E" GREATER THAN 6 1/2" USE REPAIR P 2)

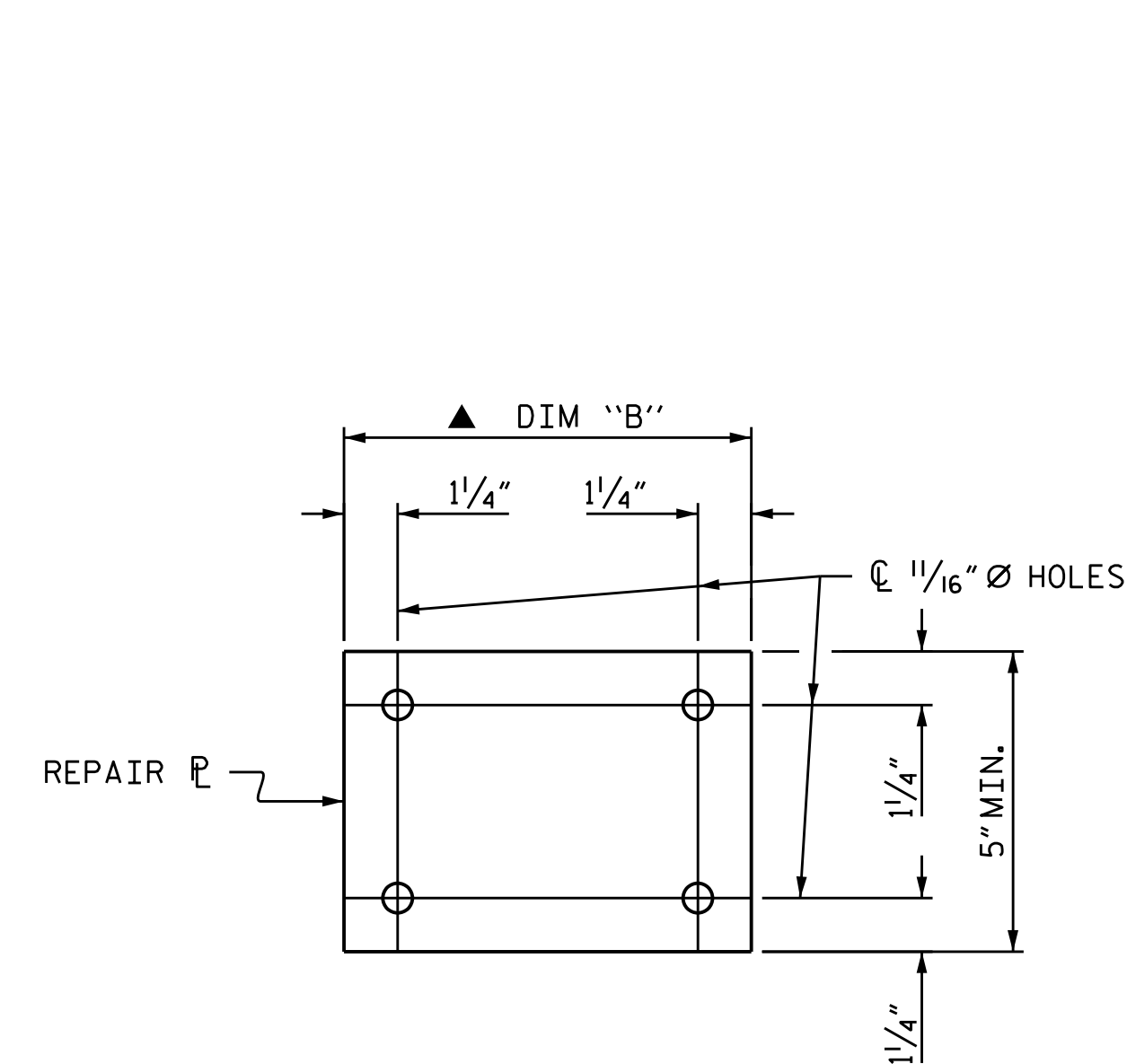

REPAIR P 1 DETAIL
 (2-PLATES REQ'D PER REPAIR)

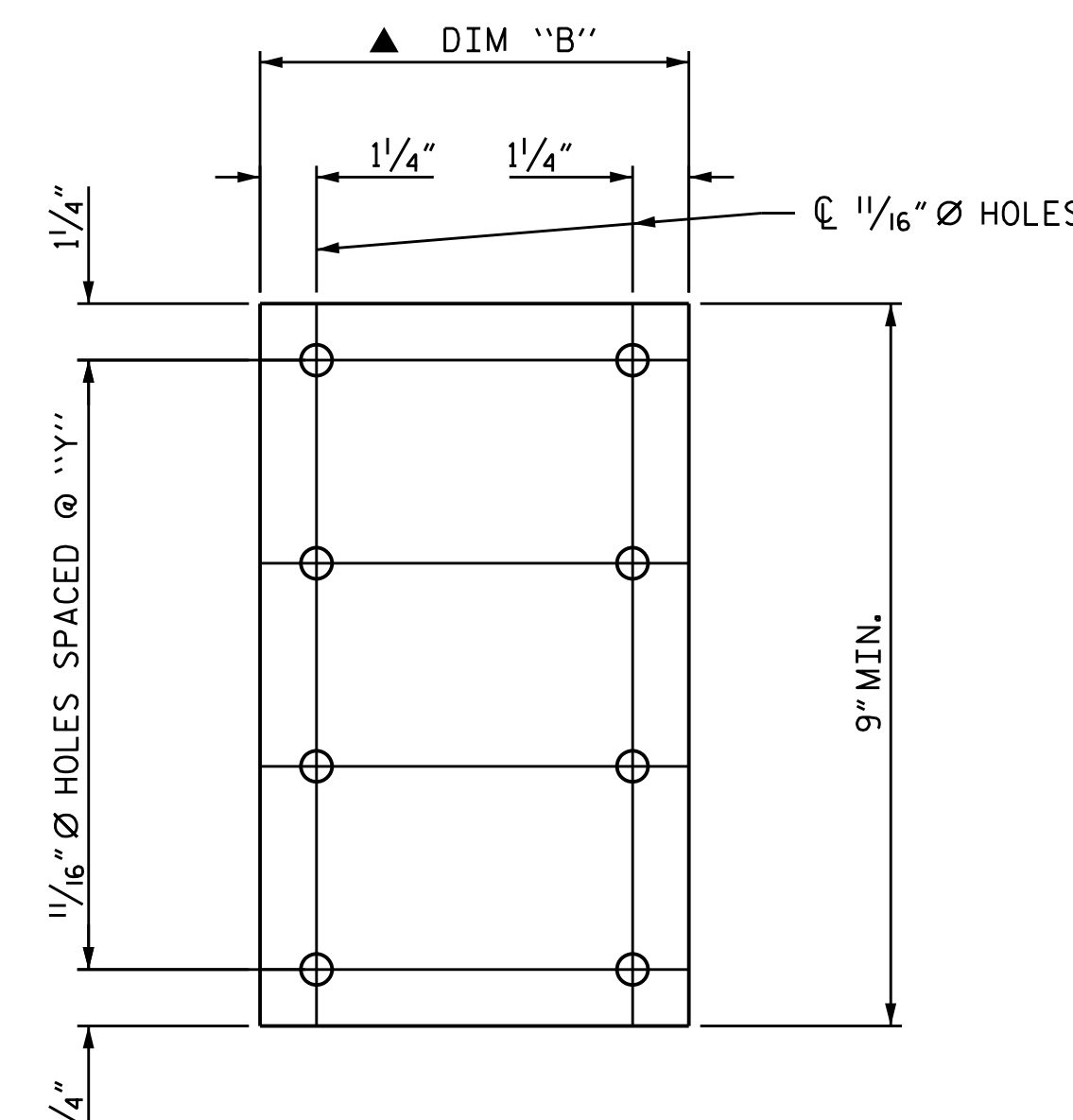

REPAIR P 2 DETAIL
 (2-PLATES REQ'D PER REPAIR)