

PLAN - TOP OF CAP

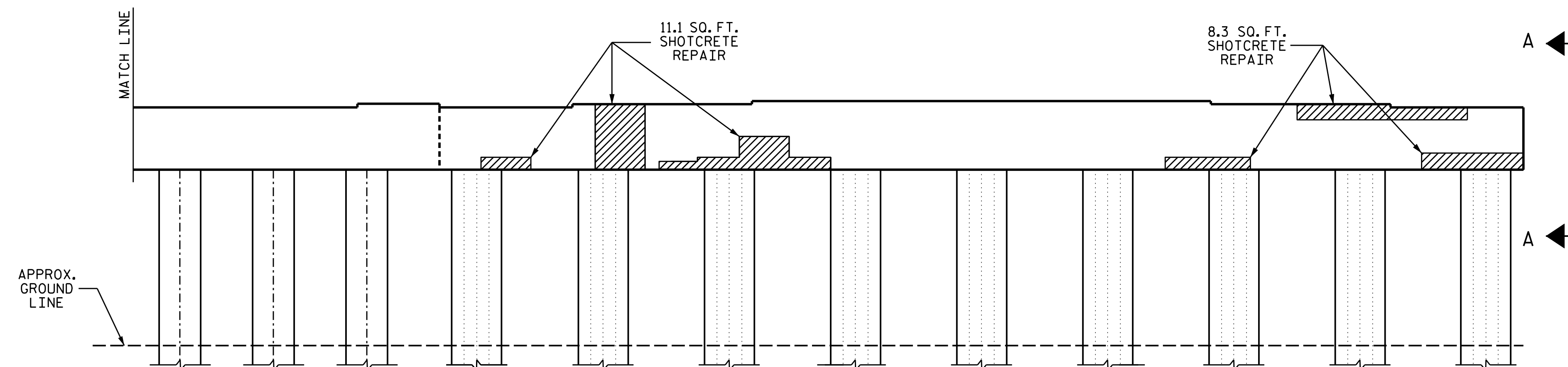

SPAN D VIEW - ELEVATION

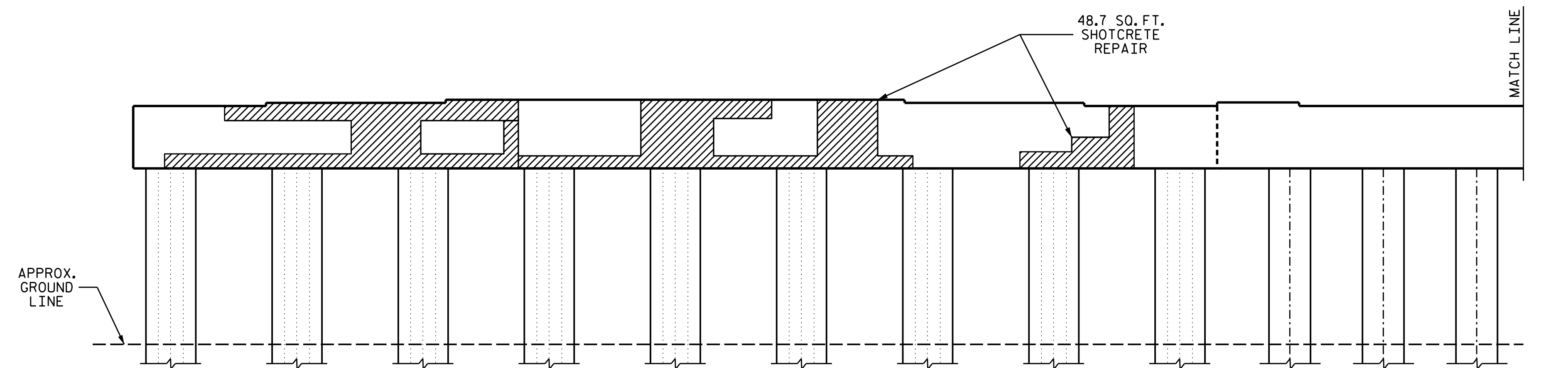
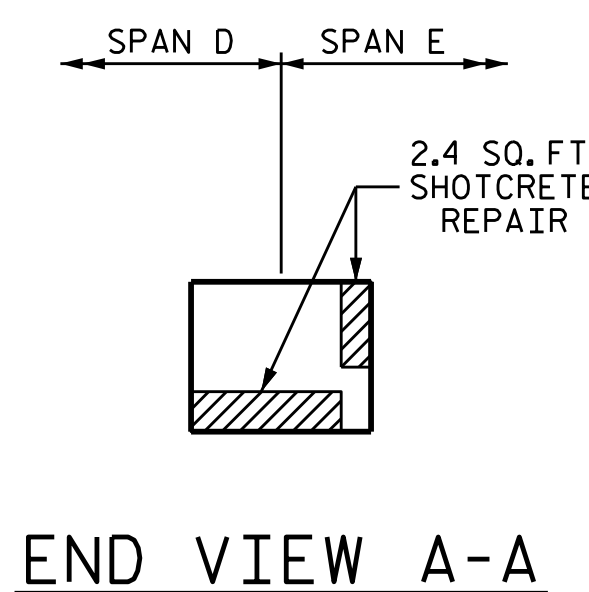

END VIEW A-A

NOTES:
 REPAIR LOCATIONS AND ESTIMATE OF QUANTITIES ARE BASED ON THE BEST INFORMATION AVAILABLE. IF ADDITIONAL REPAIRS NOT SHOWN ON THE DRAWINGS ARE DEEMED NECESSARY BY THE ENGINEER, THE ENGINEER WILL NOTE ON THE DRAWINGS THE APPROXIMATE LOCATIONS AND DESCRIPTION OF THE REPAIRS AND ENTER THE ACTUAL QUANTITIES ENTERED INTO THE AS-BUILT REPAIR QUANTITY TABLE.
 FOR SHOTCRETE REPAIR, SEE SPECIAL PROVISIONS.
 FOR CONCRETE REPAIRS, SEE SPECIAL PROVISIONS.
 SHOTCRETE REPAIRS MAY BE SUBSTITUTED IN LIEU OF CONCRETE REPAIRS WITH THE APPROVAL OF THE ENGINEER.
 FOR EPOXY RESIN INJECTION, SEE SPECIAL PROVISIONS.
 CLEAN AND REMOVE DEBRIS FROM THE TOP OF THE CAP AND APPLY EPOXY PROTECTIVE COATING TO THE TOP SURFACE OF THE CAP. THE CONTRACTOR SHALL NOT COAT THE AREA OF THE CAP BENEATH THE MASONRY PLATES. FOR EPOXY COATING, SEE SPECIAL PROVISIONS.

AS-BUILT REPAIR QUANTITY TABLE				
BENT 4 (D FACE)	QUANTITIES			
	ESTIMATE		ACTUAL	
SHOTCRETE REPAIRS	AREA SF	VOLUME CF	AREA SF	VOLUME CF
CAP	70.5	35.3		
COLUMN	0.0	0.0		
CONCRETE REPAIRS	AREA SF	VOLUME CF	AREA SF	VOLUME CF
CAP	7.9	4.0		
EPOXY RESIN INJECTION		LN. FT.		LN. FT.
CAP		3.0		
COLUMN		0.0		
EPOXY COATING		SQ. FT.		SQ. FT.
TOP OF BENT CAP		263.6		

VALUES IN CHART REPRESENT ESTIMATED REPAIR TOTALS AFTER REMOVAL OF UNSOUND CONCRETE, MINIMUM OF 1" BEHIND REBAR AND MINIMUM 2" CLEARANCE TO SAWCUT. FOR REPAIR DETAILS, SEE "TYPICAL CAP AND COLUMN REPAIR DETAILS" SHEET.

- SHOTCRETE AREA
- CONCRETE AREA
- ERI - EPOXY RESIN INJECTION

DRAWN BY : A. SORSENGINH DATE : 12/2020
 CHECKED BY : M. G. SHAIKH DATE : 7/2021

1/25/2022
 P:\15BPR55\Structures\Final Plans\402.045.15BPR.55.SMU. B4D.S23.330227.dgn
 ksedai

DOCUMENT NOT CONSIDERED FINAL UNLESS ALL SIGNATURES COMPLETED

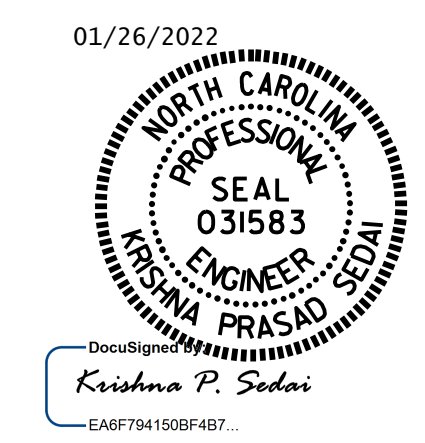

PROJECT NO. 15BPR.55
 FORSYTH COUNTY
 BRIDGE NO. 330227
 SHEET 1 OF 2

STATE OF NORTH CAROLINA
 DEPARTMENT OF TRANSPORTATION
 RALEIGH
**BENT 4
 SPAN D FACE**

REVISIONS						SHEET NO.
NO.	BY:	DATE:	NO.	BY:	DATE:	
1			3			S2-23
2			4			TOTAL SHEETS 79