

EXISTING JOINT

MINIMUM EXISTING JOINT DEMOLITION

PROPOSED JOINT PRE-SAWED DIMENSIONS

PROPOSED FOAM JOINT SEAL

JOINT INSTALLATION SEQUENCE AT BENTS
SECTION B-B

JOINT REPAIR QUANTITY TABLE			
	BRIDGE JOINT DEMOLITION	FOAM JOINT SEALS FOR PRESERVATION	ELASTOMERIC CONCRETE FOR PRESERVATION
BENT 1	90.0 SQ. FT.	90.0 LF	22.5 CU. FT.
BENT 2	90.0 SQ. FT.	90.0 LF	22.5 CU. FT.
BENT 3	90.0 SQ. FT.	90.0 LF	22.5 CU. FT.
* TOTAL	270.0 SQ. FT.	270.0 LF	67.5 CU. FT.

* BASED ON THE MINIMUM BLOCKOUT SHOWN.

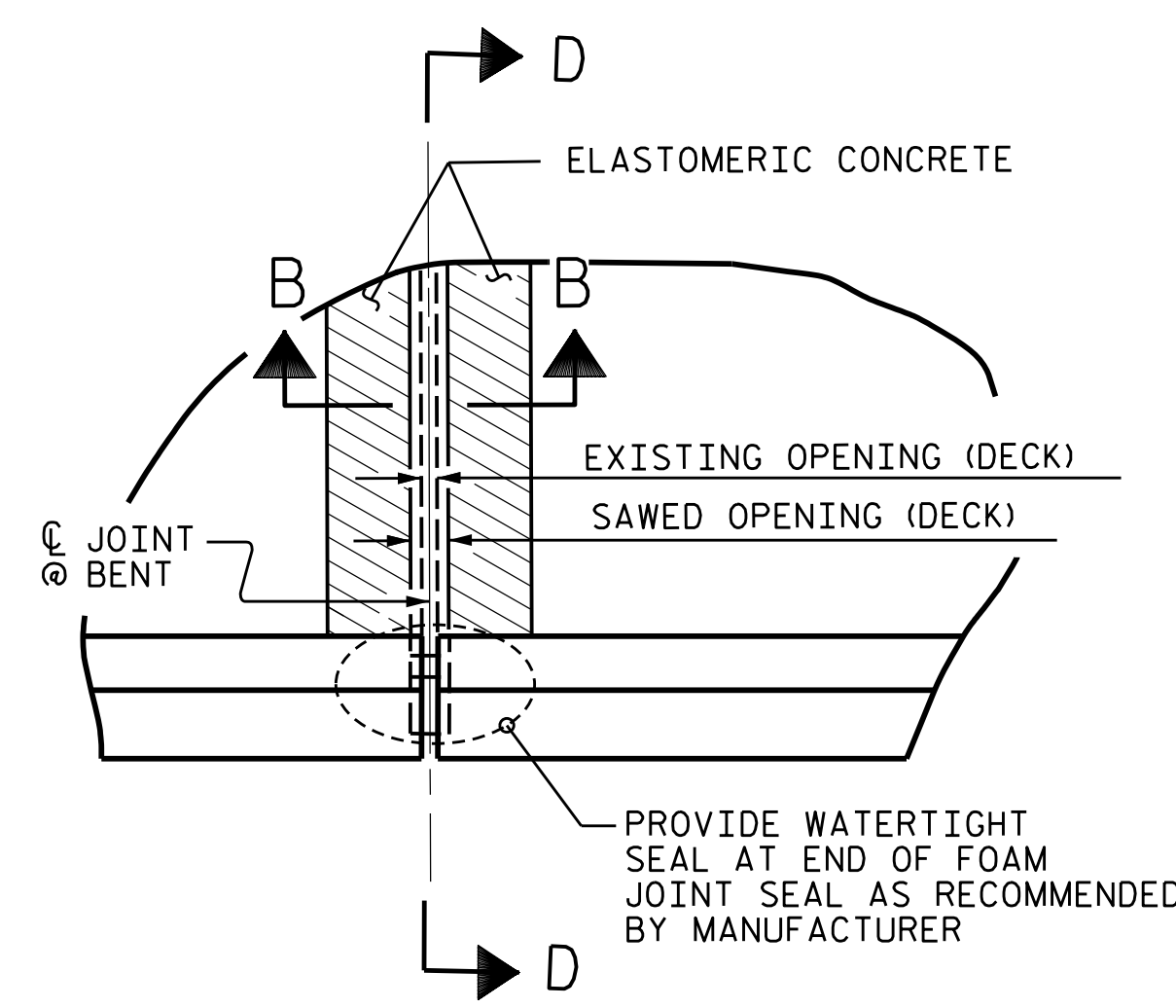

PLAN
(@ BENTS)

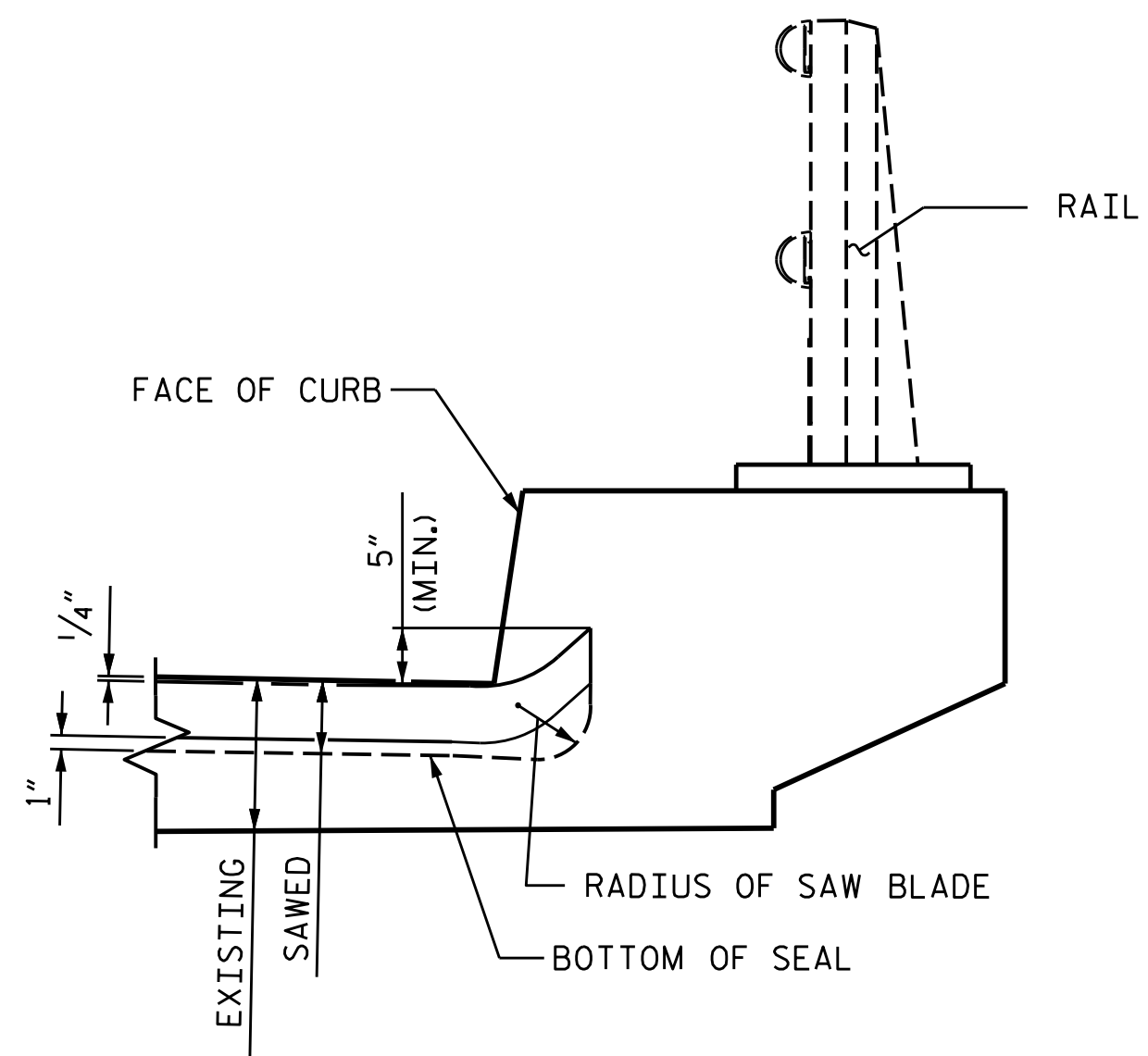

SECTION D-D
(@ BENTS)

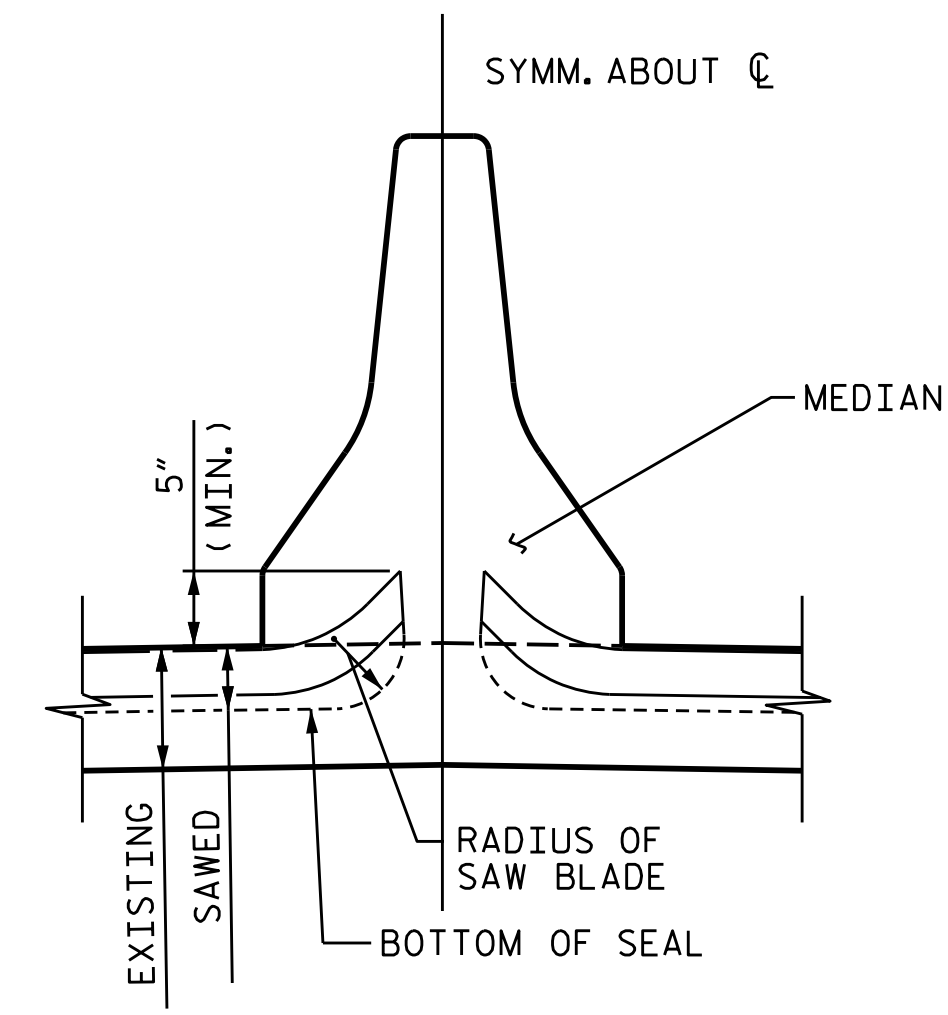

MEDIAN DETAIL
FOAM JOINT SEAL SHALL BE FACTORY FORMED OR CUT, HEAT WELDED AND TURNED UP PARALLEL TO FACE OF MEDIAN.

NOTES

- FINAL JOINT SEALS SHALL NOT BE INSTALLED UNTIL THE OVERLAY OR SEALANT WORK IS COMPLETE.
- THE CONTRACTOR SHALL FIELD VERIFY THE EXISTING JOINT OPENING PRIOR TO ORDERING JOINT SEAL MATERIAL. IF THE ACTUAL JOINT OPENING VARIES FROM THE OPENING INDICATED IN THE DETAILS BY MORE THAN 1/4", NOTIFY THE ENGINEER.
- THE MANUFACTURER IS TO PROVIDE THE NOMINAL UNCOMPRESSED SEAL WIDTH OF THE FOAM JOINT SEAL FOR THE SIZE OF THE OPENING ON THE PLANS AND THAT ACCOMMODATE THE MINIMUM EXPANSION SHOWN ON THE PLANS.
- FOAM JOINT SEALS FOR PRESERVATION SHALL BE INSTALLED AS PER THE MANUFACTURER'S RECOMMENDATIONS.
- THE CONTRACTOR SHALL TAKE CARE DURING JOINT REHAB OPERATIONS NOT TO DROP ANY MATERIAL BELOW THE BRIDGE WITHOUT PROTECTIVE DEVICES BELOW TO CATCH THE MATERIAL. ANY MATERIAL THAT FALLS BELOW THE BRIDGE SHALL BE CONTAINED, REMOVED AND DISPOSED OF BY THE CONTRACTOR AT NO EXTRA COST TO THE DEPARTMENT. IF THE ENGINEER DETERMINES THAT THE PROTECTIVE DEVICES ARE NOT ADEQUATE OR NOT BEING EMPLOYED, THE WORK SHALL BE SUSPENDED UNTIL ADEQUATE PROTECTION IS PROVIDED.
- THE CONTRACTOR WILL NOT BE PERMITTED TO FORM THE JOINTS IN LIEU OF SAWING THE JOINT.
- THE INSTALLED FOAM JOINTS SHALL BE WATER TIGHT.
- FOR FOAM JOINT SEALS FOR PRESERVATION, SEE SPECIAL PROVISIONS.
- THE CONTRACTOR SHALL SAW CUT TO A NOMINAL DEPTH OF 1/2" BUT REINFORCING STEEL SHALL NOT BE DAMAGED. CONTRACTOR SHALL REMOVE SURFACE CONCRETE TO VERIFY THAT SAWCUT DEPTH WILL NOT DAMAGE EXISTING REINFORCING STEEL.
- QUANTITIES SHOWN IN THE ELASTOMERIC CONCRETE FOR PRESERVATION TABLE ARE BASED ON THE MINIMUM JOINT DEMOLITION SHOWN.
- FOR EXCAVATION BELOW THE BOTTOM OF THE PLANNED JOINT DEMOLITION, CONCRETE FOR DECK REPAIR SHALL BE PLACED IN THE EXCAVATED AREA TO THE ELEVATION AT BOTTOM OF THE PROPOSED ELASTOMERIC CONCRETE FOR PRESERVATION HEADERS SHOWN.
- FOR BRIDGE JOINT DEMOLITION, SEE SPECIAL PROVISIONS.
- FOR ELASTOMERIC CONCRETE FOR PRESERVATION, SEE SPECIAL PROVISIONS.

PROJECT NO. 15BPR.55
FORSYTH COUNTY
BRIDGE NO. 330078

SHEET 2 OF 2

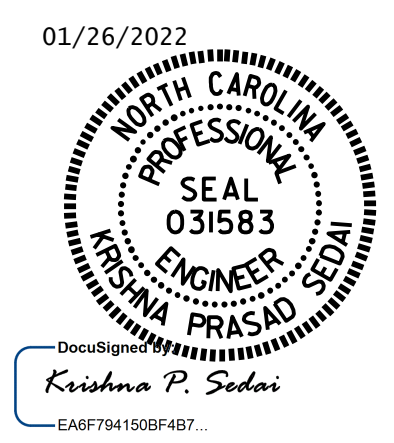

STATE OF NORTH CAROLINA
DEPARTMENT OF TRANSPORTATION
RALEIGH

JOINT DETAILS

DRAWN BY : E. BAYISSA DATE : 09/2020
CHECKED BY : A. SORSENGINH DATE : 07/2021

REVISIONS						SHEET NO.
NO.	BY:	DATE:	NO.	BY:	DATE:	S1-09
1			3			TOTAL SHEETS
2			4			79

DOCUMENT NOT CONSIDERED FINAL UNLESS ALL SIGNATURES COMPLETED