

T.I.P.: U-5798A

CONTRACT: C204507

**STATE OF NORTH CAROLINA
DEPARTMENT OF TRANSPORTATION**

**SIGNING PLAN
CUMBERLAND COUNTY**

**LOCATION: WIDEN SR 1102 (GILLIS HILL ROAD) TO MULTI-LANES
FROM US 401 (RAEFORD ROAD) TO SR 1007
(STONE POINT ROAD)**

ROADWAY STANDARD DRAWING

THE FOLLOWING ROADWAY STANDARDS AS APPEAR IN "ROADWAY STANDARD DRAWINGS" - PROJECT SERVICES UNIT - N.C. DEPARTMENT OF TRANSPORTATION - RALEIGH, N.C., DATED JANUARY 2018 ARE APPLICABLE TO THIS PROJECT AND BY REFERENCE HEREBY ARE CONSIDERED A PART OF THESE PLANS:

STD. NO.	TITLE
903.10	GROUND MOUNTED SIGN SUPPORTS
904.10	ORIENTATION OF GROUND MOUNTED SIGNS
904.50	MOUNTING OF TYPE 'D', 'E' AND 'F' SIGNS ON 'U' CHANNEL POSTS
910.30	SIGNING FOR SUPERSTREETS
1264.01	OBJECT MARKERS
1264.02	PLACEMENT OF OBJECT MARKERS

SUMMARY OF QUANTITIES



ITEM NO.		ITEM DESCRIPTION	QUANTITY	UNIT
DESC. NO.	SECT. NO.			
4026000000	902	DEPARTMENT FURNISHED, TYPE D SIGN	12	S.F.
4026000000	902	DEPARTMENT FURNISHED, TYPE E SIGN	233	S.F.
4026000000	902	DEPARTMENT FURNISHED, TYPE F SIGN	32	S.F.
4072000000	903	SUPPORTS, 3 LB STEEL U-CHANNEL	370	L.F.
4096000000	904	SIGN ERECTION, TYPE D	2	EA.
4102000000	904	SIGN ERECTION, TYPE E	29	EA.
4108000000	904	SIGN ERECTION, TYPE F	3	EA.
4116100000	904	SIGN ERECTION, RELOCATE SIGN TYPE D	4	EA.
4155000000	907	DISPOSAL OF SIGN SYSTEM, U-CHANNEL	31	EA.

GENERAL NOTES

- SIGNS FURNISHED BY DEPARTMENT.
- CONFIRM IN WRITING AT LEAST 4 MONTHS IN ADVANCE, THE ACTUAL DATE THE DEPARTMENT FURNISHED SIGNS WILL BE REQUIRED.
- ALL TYPE 'D' SIGNS SHALL BE MOUNTED ON TWO U-CHANNEL POSTS UNLESS OTHERWISE INDICATED ON THE PLANS.
- IF REMOVAL OR RELOCATION OF SIGNS ON PRIVATE STREET (NON-STATE MAINTAINED) IS REQUIRED DUE TO CONSTRUCTION, THE CONTRACTOR SHALL INFORM THE ENGINEER. THE WORK WILL BE COMPLETED BY OTHERS.
- WHEN NOT STATIONED OR DIMENSIONED ON PLANS, ALL 'E' AND 'F' SIGNS SHALL BE FIELD LOCATED BY THE ENGINEER.
- ALL EXISTING SIGNS ON "U" CHANNEL POST WITHIN THE PROJECT LIMITS SHALL BE REMOVED AND DISPOSED OF UNLESS OTHERWISE NOTED ON PLANS.
- WHEN EXISTING SIGNS ARE REMOVED AND INSTALLED ON NEW SUPPORTS, THE RE-ERECTION SHALL IMMEDIATELY FOLLOW THE REMOVAL.
- THE BACKGROUND FOR TYPE E & F SIGNS SHALL BE TYPE C REFLECTIVE SHEETING.
- SEE ROADWAY PLANS FOR GUARD/GUIDE RAIL DETAILS.

INDEX

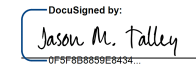
SHEET NO.	DESCRIPTION
SIGN-1	TITLE SHEET
SIGN-2	E SHEET
SIGN-2A	F SHEET
SIGN-3	SIGN DESIGNS
SIGN-4-9	PROPOSED AND EXISTING SIGN DETAIL SHEETS

TIP NO. U-5798A	SHEET NO. SIGN- 1
APPROVED: 	
DATE: 1/16/2022	
	
DOCUMENT NOT CONSIDERED FINAL UNLESS ALL SIGNATURES COMPLETED	

PLAN PREPARED BY: RS&H

THOMAS E. HILDEBRAND, PE	PROJECT ENGINEER
JASON M. TALLEY, PE	PROJECT DESIGN ENGINEER



APPROVED: *Jason M. Talley*
DATE: 1/16/2022

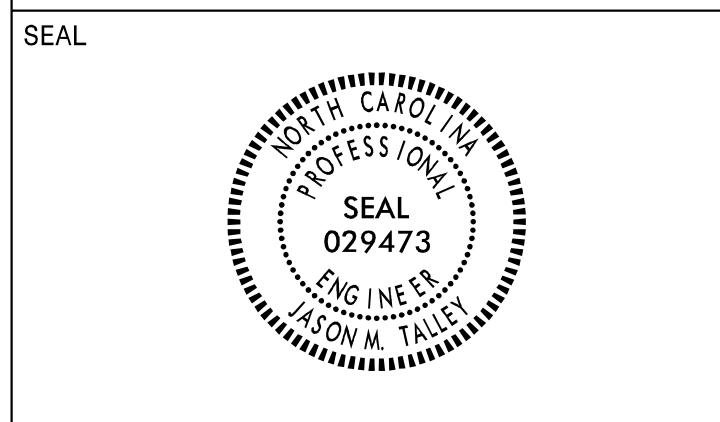

**DOCUMENT NOT CONSIDERED FINAL
UNLESS ALL SIGNATURES COMPLETED**

401 QUANTITY REQ'D 6

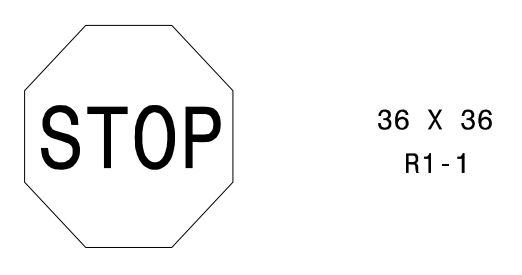

ONE "U" POST PER SIGN

402 QUANTITY REQ'D 3

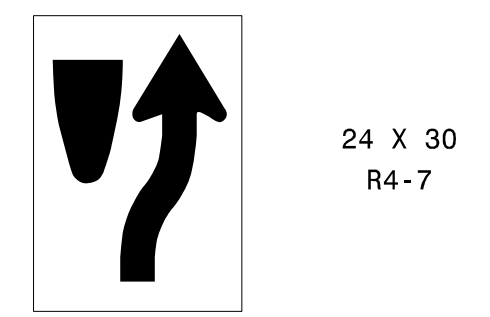

ONE "U" POST PER SIGN

403 QUANTITY REQ'D 3

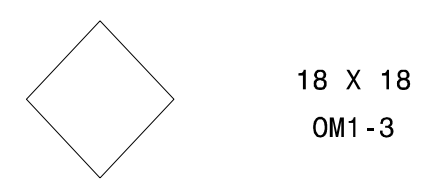

TO BE MOUNTED UNDER 402
IN 3 INSTALLATIONS

404 QUANTITY REQ'D 4

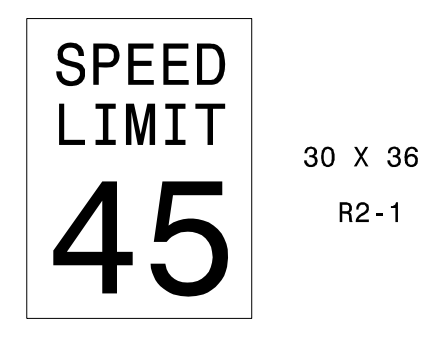

ONE "U" POST PER SIGN

405 QUANTITY REQ'D 7



TO BE MOUNTED ABOVE 401
IN 6 INSTALLATIONS
TO BE MOUNTED WITH 406
IN 1 INSTALLATIONS

406 QUANTITY REQ'D 3



TWO "U" POSTS PER SIGN

407 QUANTITY REQ'D 2



ONE "U" POST PER SIGN

408 QUANTITY REQ'D 1



ONE "U" POST PER SIGN

409 QUANTITY REQ'D 2



ONE "U" POST PER SIGN

410 QUANTITY REQ'D 2



ONE "U" POST PER SIGN

411 QUANTITY REQ'D 1

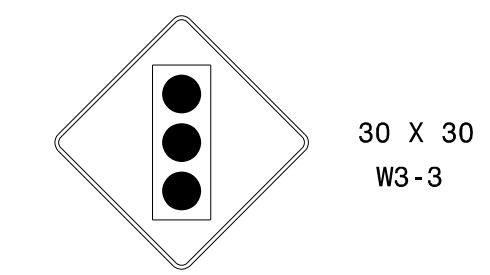

ONE "U" POST PER SIGN

412 QUANTITY REQ'D 1

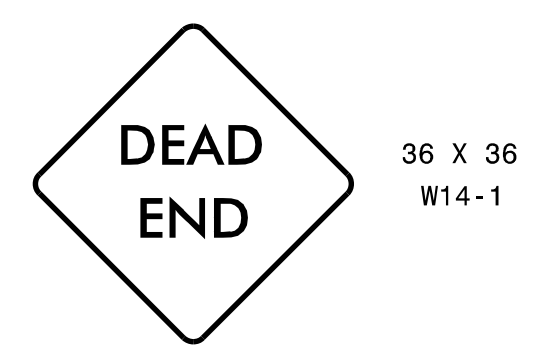

ONE "U" POST PER SIGN

413 QUANTITY REQ'D 2

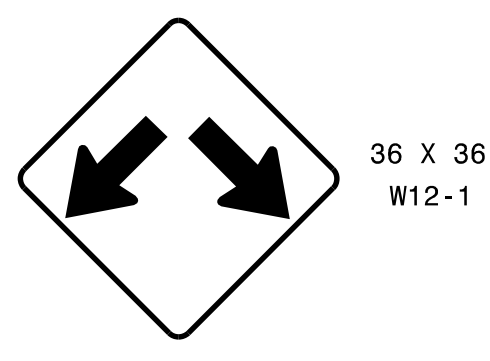

ONE "U" POST PER SIGN

414 QUANTITY REQ'D 2

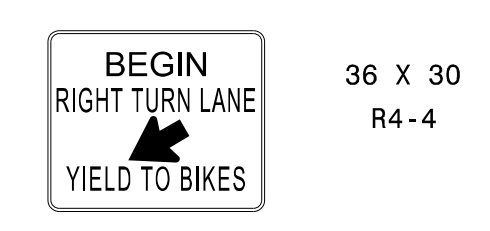

ONE "U" POST PER SIGN

415 QUANTITY REQ'D 1





TO BE MOUNTED UNDER 410
IN 1 INSTALLATION

R2/20/2021
R:\Traffic\Signing\CADD\Signing Layout Plans\U5798A_sign_e_sign.dgn
User:rlcaughn

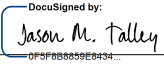

TYPE "E" SIGNS

TIP NO. U-5798A	SHEET NO. SIGN-2A
APPROVED: 	
DATE: 1/16/2022	
SEAL 	
DOCUMENT NOT CONSIDERED FINAL UNLESS ALL SIGNATURES COMPLETED	

501 QUANTITY REQ'D 1

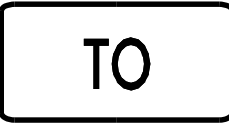
 24 X 12
M4-5

 30 X 24
M1-4

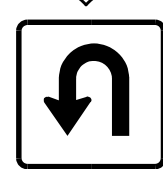
 21 X 21
SIGN DESIGN
(SHEET SIGN-3)

 24 X 12
W16-9P

ONE "U" POST PER SIGN

502 QUANTITY REQ'D 1

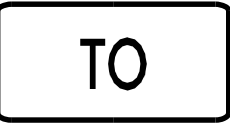
 24 X 12
M4-5

 30 X 24
M1-4

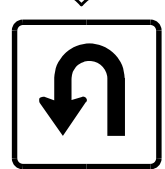
 21 X 21
SIGN DESIGN
(SHEET SIGN-3)

ONE "U" POST PER SIGN

503 QUANTITY REQ'D 1

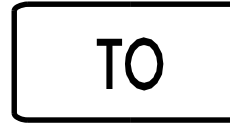
 24 X 12
M4-5

 30 X 24
M1-4

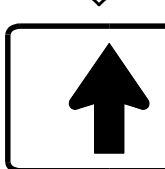
 21 X 15
M6-3

ONE "U" POST PER SIGN

***NOTE: SEE SHEET SIGN-3 FOR
U-TURN DIRECTIONAL ARROW SIGN
DESIGN DETAILS.**



TYPE "F" SIGNS

12/20/2021
P:\Traffic\Signing\CADD\Signing Layout Plans\U5798A_sign-f_sign.dgn
User:htclough

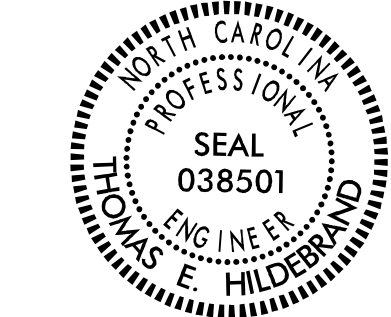
TIP NO. U-5798A	SHEET NO. SIGN-3
APPROVED: 	
DATE: 1/13/2022	
SEAL	
DOCUMENT NOT CONSIDERED FINAL UNLESS ALL SIGNATURES COMPLETED	

SIGN NUMR: TYPE: F Ground QUANTITY: 1	BACKG. COLOR: White COPY COLOR: Black	DESIGN BY: PROJECT ID:	CHK BY: DIV:	STD #: DATE:	N. C. DEPARTMENT OF TRANSPORTATION DIVISION OF HIGHWAYS TRANSPORTATION MOBILITY & SAFETY SIGNING & DELINEATION UNIT
---	--	---------------------------	-----------------	-----------------	--

SIGN WIDTH: 1'-9"
HEIGHT: 1'-9"
TOTAL AREA: 3.1 Sq.Ft.

SYMBOL	X	Y	WID	HT
u arrow	3.7	3.5	12.7	13.9

MAT'L: 0.063" ALUMINUM

BORDER TYPE: RECESSED
RECESS: 0.38"
WIDTH: 0.63"
RADI: 1.5"
NO. Z BARS:
LENGTH:

NOTES:
1. Legend and border shall be direct applied
Non-reflective sheeting.
2. Background shall be Grade C reflective sheeting.

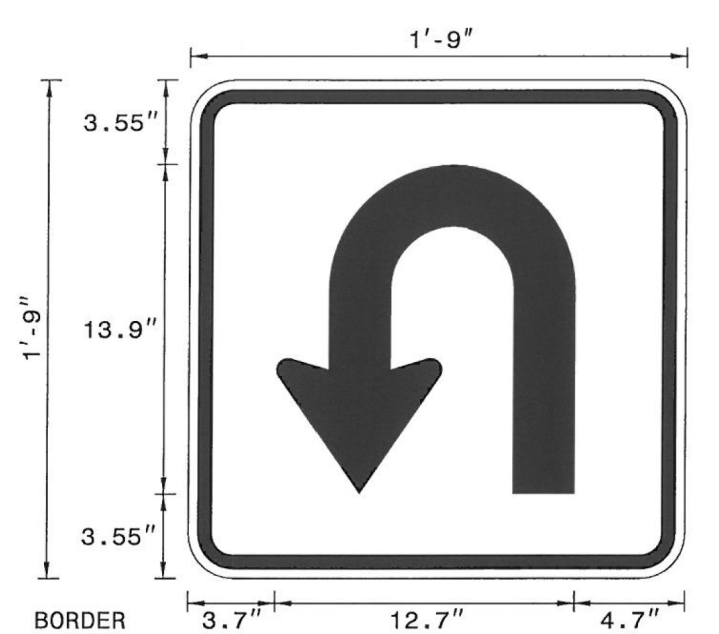

BORDER
R=1.5"
TH=0.63"
IN=0.38"

Arrow Details

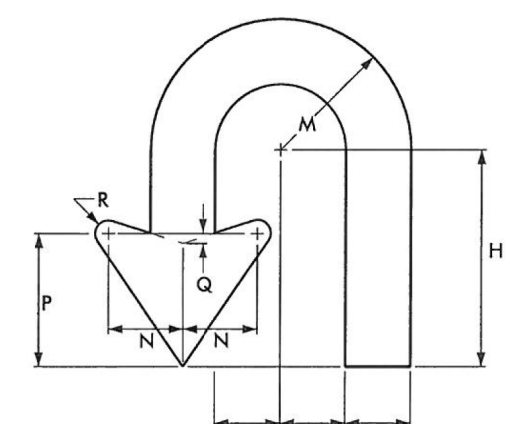

ARROW DIMENSIONS (INCHES)	F	G	H	M	N	P	Q	R
	2.625	2.625	8.659	5.25	3	5.25	0.375	0.5

Spacing Factor is 1 unless specified otherwise
FILENAME: GSENG

SIGN NUMBER: 302 TYPE: D QUANTITY: 2	BACKG COLOR: Green COPY COLOR: White	DESIGN BY: REM PROJECT ID: U-5798A	CHECKED BY: TEH LOCATION: CUMBERLAND	Oct 07, 2021 DIV: 6
--	---	---------------------------------------	---	------------------------

SIGN WIDTH: 4'-0"
HEIGHT: 1'-6"
TOTAL AREA: 6.0 Sq.Ft.

BORDER TYPE: FLUSH
RECESS: 0"
WIDTH: 0.5"
RADI: 1.5"

NO. Z BARS:
LENGTH:

MAT'L: 0.063" (1.6 mm) ALUMINUM
0.080" (2.0 mm) ALUMINUM
0.125" (3.2 mm) ALUMINUM

USE NOTES:
1. Legend and border(except those that are colored black) shall be direct applied Grade C sheeting.
2. Background shall be Grade A, B, or C reflective sheeting.
3. Shields; A, B, and C type arrows shall be on 0.032" (0.8mm) aluminum with Grade C reflective sheeting and demountable.

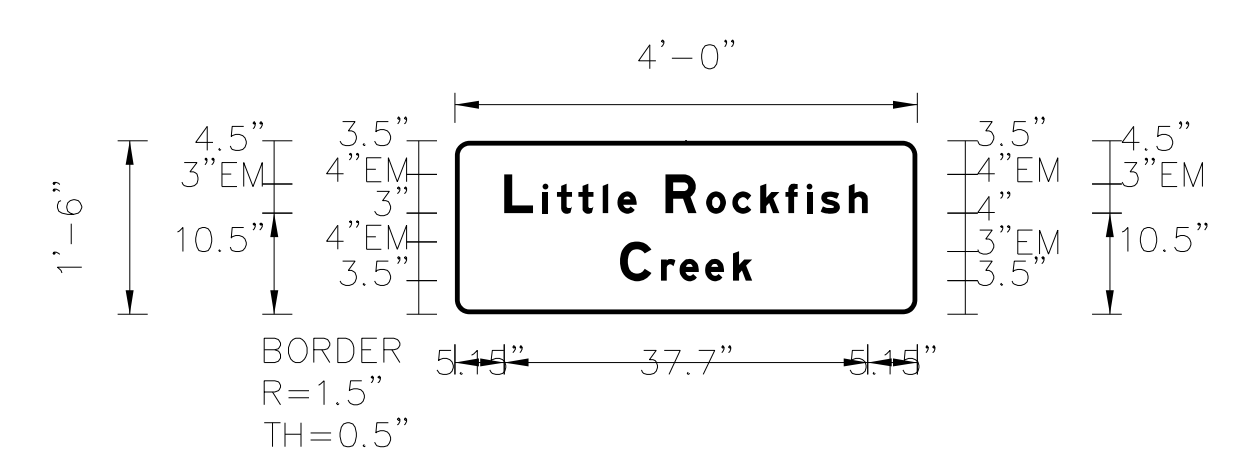

Spacing Factor is 1 unless specified otherwise

LETTER POSITIONS

Letter spacings are to start of next letter

	L	i	t	t	l	e	R	o	c	k	f	i	s	h					Series/Size Text Length
5.1	3	1	1.5	2.2	2.5	1.5	2	3	3.2	1	2.7	2.9	2.6	2.2	1.5	2.9	2	5.1	EM 2000 37.7
17.1	3.2	1	1.9	2.6	2.9	2	17.1												EM 2000 13.7



FILENAME: U5798A_sign_design_CREEK

NORTH CAROLINA D.O.T. SIGN DETAIL

12/20/2021
P:\Traffic\Signing\CADD\Signing Layout Plans\U5798A_sign_designs.dgn
User:rlaught

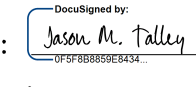

SIGN DESIGNS

TIP NO. U-5798A	SHEET NO. SIGN-4
APPROVED:  DATE: 1/16/2022	
SEAL 	
DOCUMENT NOT CONSIDERED FINAL UNLESS ALL SIGNATURES COMPLETED	

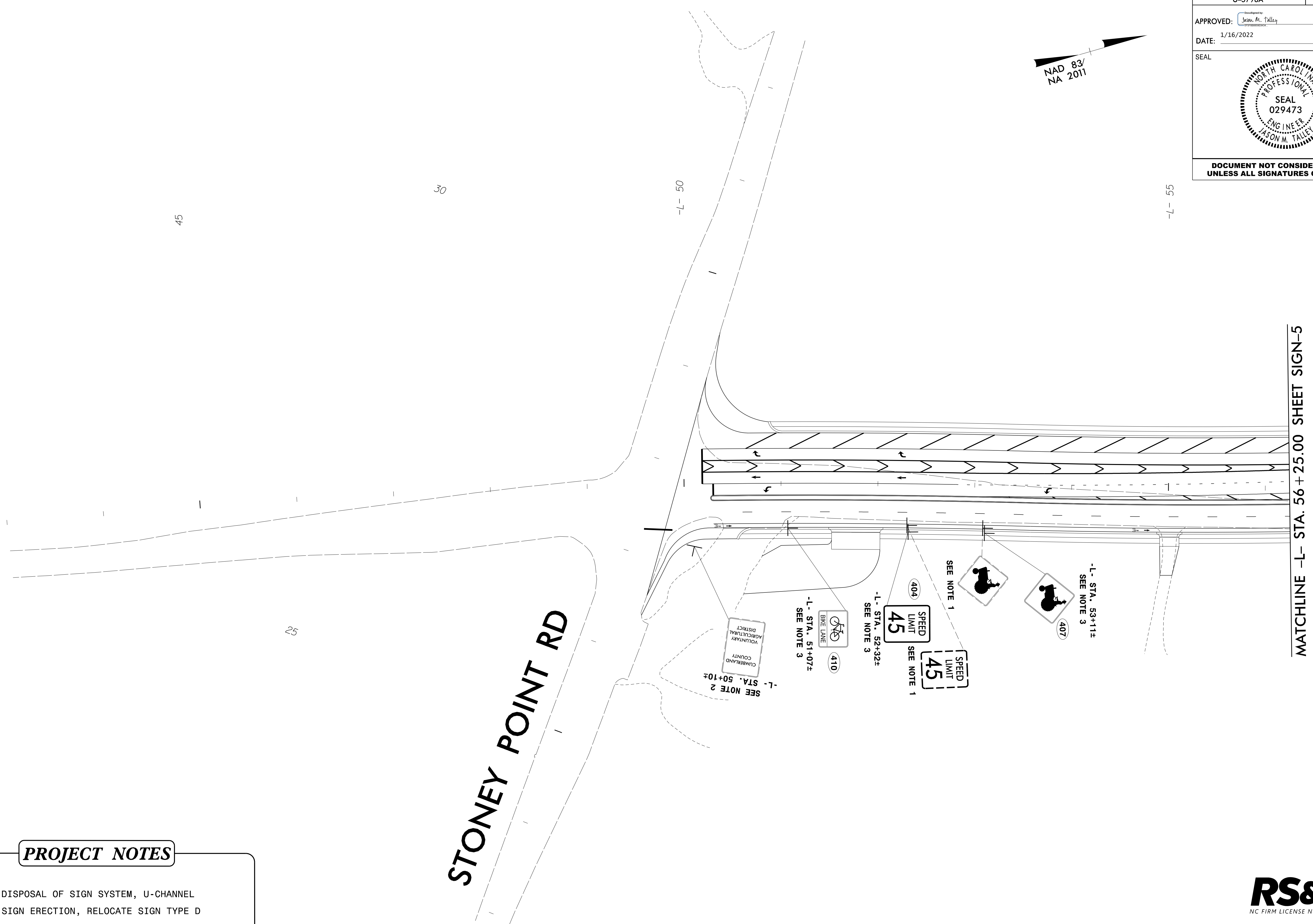
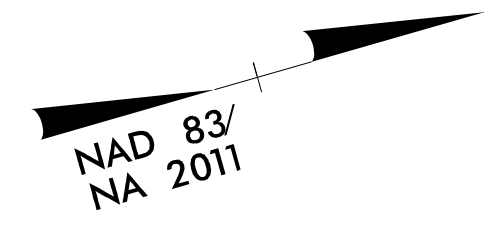

STONEY POINT RD

MATCHLINE -L- STA. 56 + 25.00 SHEET SIGN-5



PROJECT NOTES

- 1 DISPOSAL OF SIGN SYSTEM, U-CHANNEL
- 2 SIGN ERECTION, RELOCATE SIGN TYPE D
- 3 SIGN ERECTION, TYPE D, E, AND F
- 4 EXISTING SIGN SYSTEM TO REMAIN

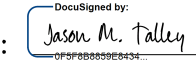

PROPOSED AND EXISTING SIGNS

12/20/2021
R:\Traffic\Signing\CADD\Signing Layout Plans\U5798A_sign_prop-dtl_01.dgn
User: jtalley

TIP NO. U-5798A	SHEET NO. SIGN-5
APPROVED:  DATE: 1/16/2022	
SEAL 	
DOCUMENT NOT CONSIDERED FINAL UNLESS ALL SIGNATURES COMPLETED	

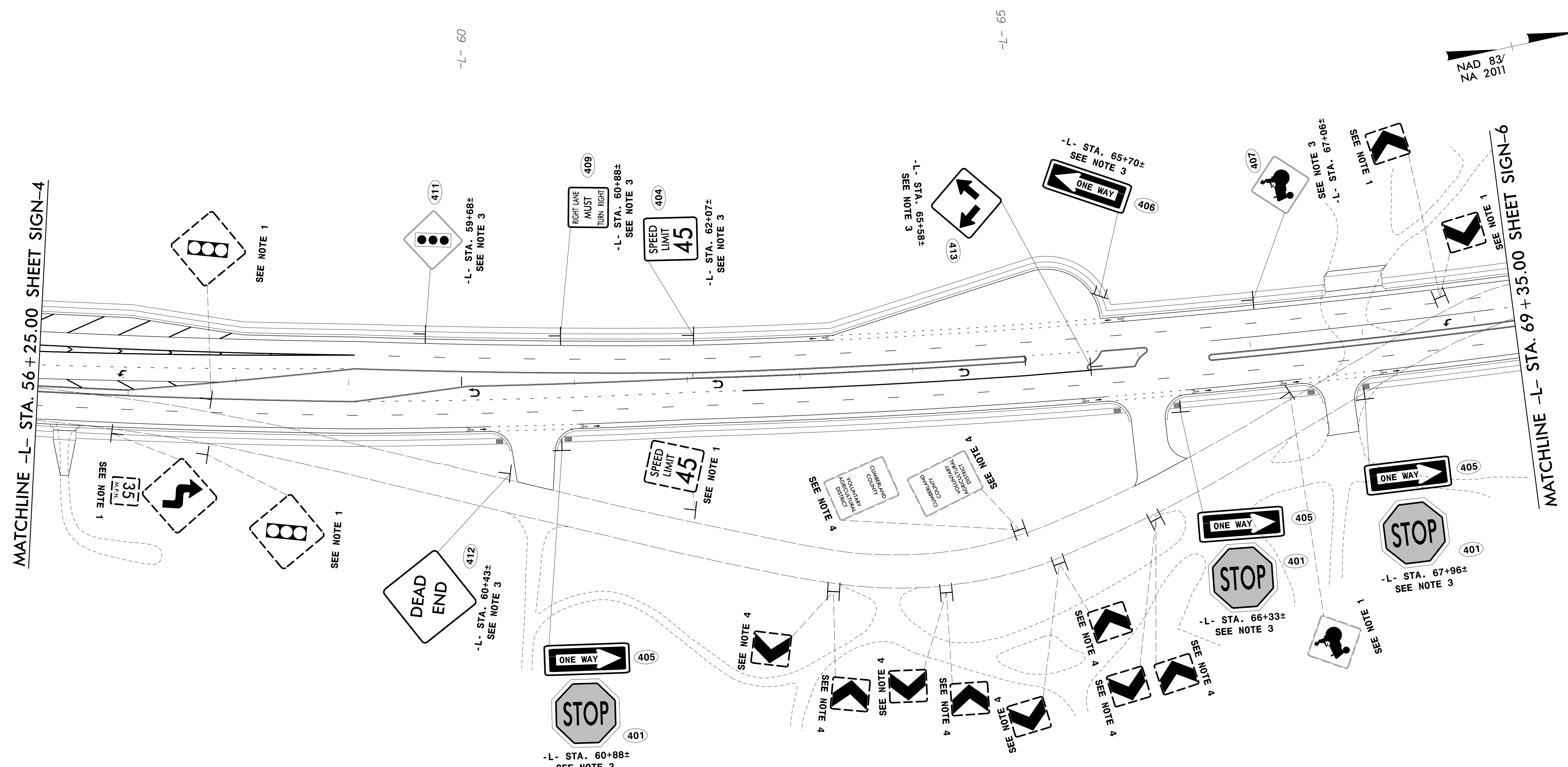
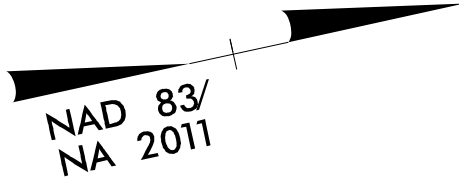

PROJECT NOTES

- 1 DISPOSAL OF SIGN SYSTEM, U-CHANNEL
- 2 SIGN ERECTION, RELOCATE SIGN TYPE D
- 3 SIGN ERECTION, TYPE D, E, AND F
- 4 EXISTING SIGN SYSTEM TO REMAIN

PROPOSED AND EXISTING SIGNS

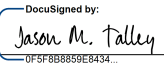
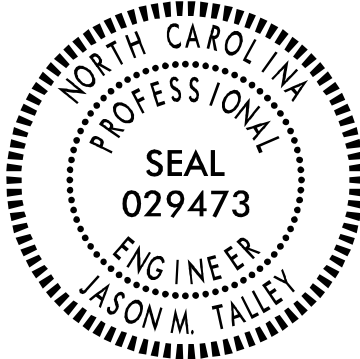

12/20/2021
R:\Traffic\Signing\CADD\Signing Layout Plans\U5798A_sign_prop-dtl.02.dgn
User:rlc\laught

TIP NO. U-5798A	SHEET NO. SIGN-6
APPROVED:  DATE: 1/16/2022	
SEAL 	
DOCUMENT NOT CONSIDERED FINAL UNLESS ALL SIGNATURES COMPLETED	

MATCHLINE -L- STA. 69 + 35.00 SHEET SIGN-5

MATCHLINE -L- STA. 82 + 60.00 SHEET SIGN-7

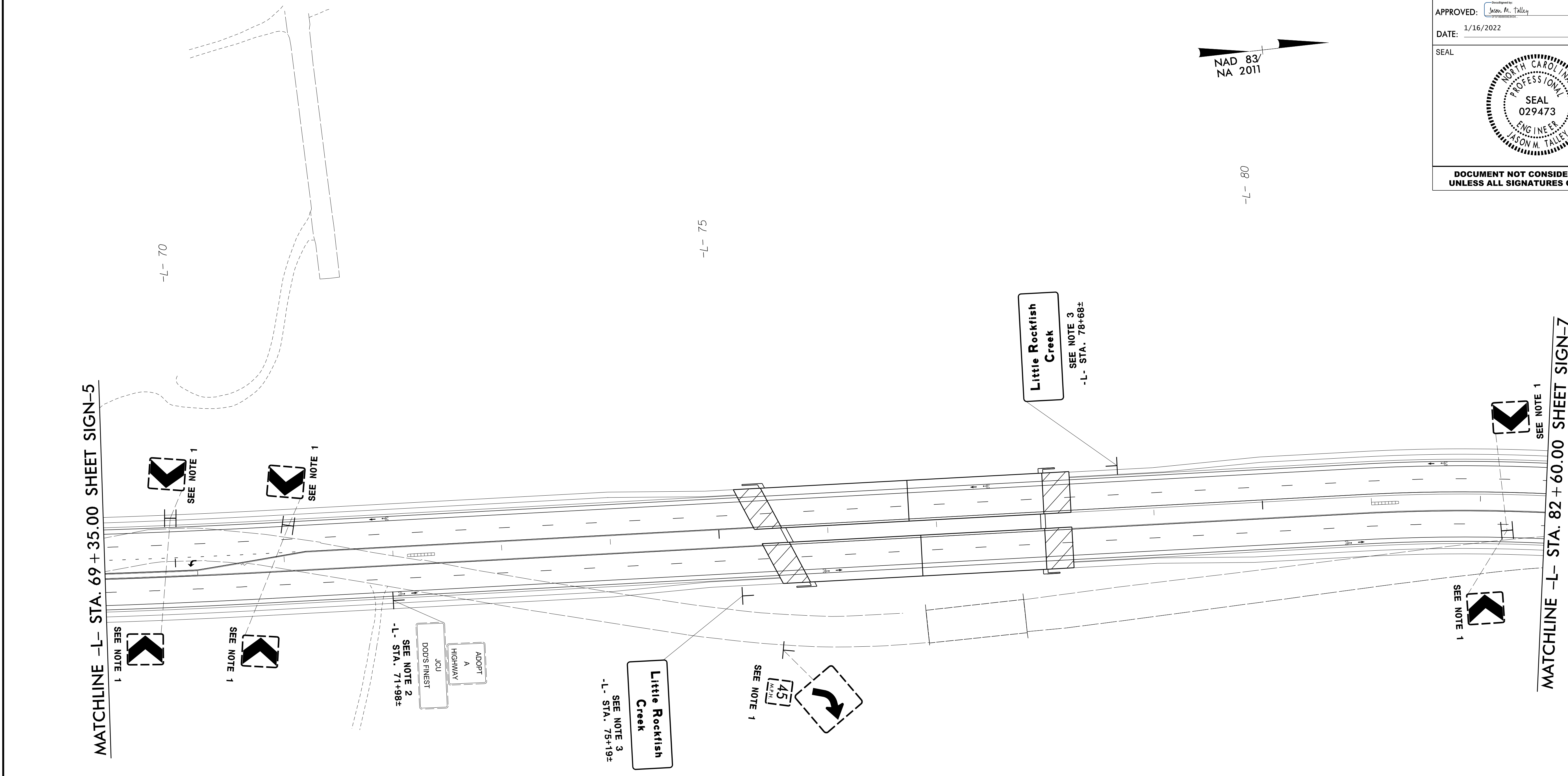
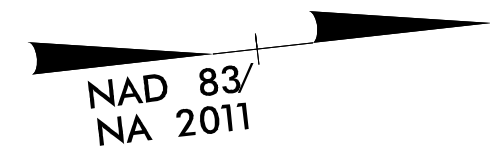

- PROJECT NOTES**
- 1 DISPOSAL OF SIGN SYSTEM, U-CHANNEL
 - 2 SIGN ERECTION, RELOCATE SIGN TYPE D
 - 3 SIGN ERECTION, TYPE D, E, AND F
 - 4 EXISTING SIGN SYSTEM TO REMAIN



12/20/2021
P:\Traffic\Signing\CADD\Signing Layout Plans\U5798A_sign_prop-dtl_03.dgn
User:htlaught



PROPOSED AND EXISTING SIGNS

TIP NO. U-5798A	SHEET NO. SIGN-7
APPROVED: 	
DATE: 1/16/2022	
SEAL	
	
DOCUMENT NOT CONSIDERED FINAL UNLESS ALL SIGNATURES COMPLETED	

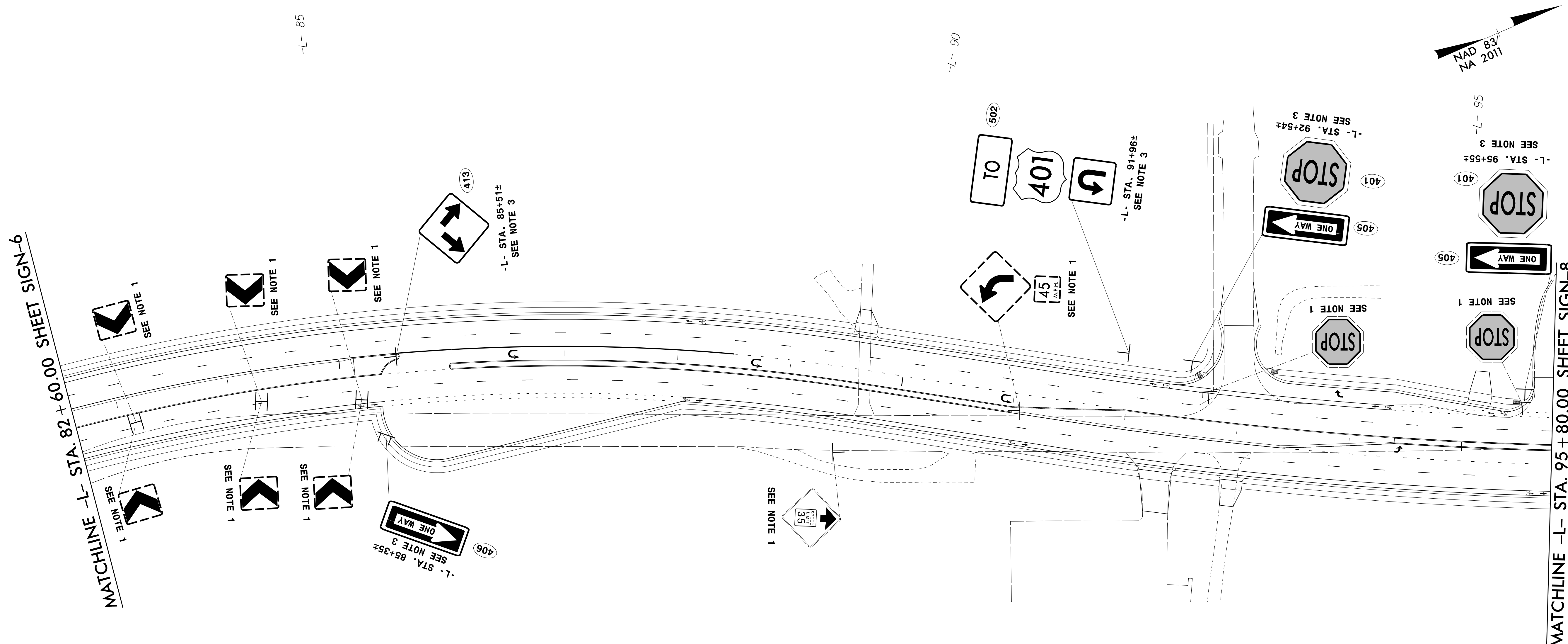

PROJECT NOTES

- 1 DISPOSAL OF SIGN SYSTEM, U-CHANNEL
- 2 SIGN ERECTION, RELOCATE SIGN TYPE D
- 3 SIGN ERECTION, TYPE D, E, AND F
- 4 EXISTING SIGN SYSTEM TO REMAIN

**PROPOSED AND
EXISTING SIGNS**



12/20/2021
 R:\Traffic\Signing\CADD\Signing Layout Plans\U5798A-sign_prop_dtl_04.dgn
 User: jcloughit

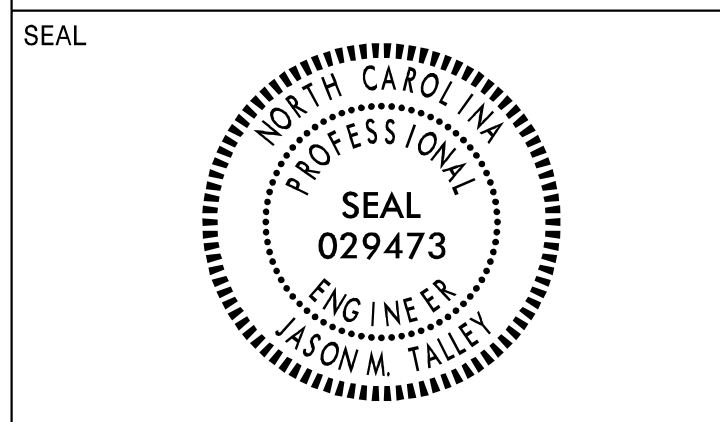

DOCUMENT NOT CONSIDERED FINAL
UNLESS ALL SIGNATURES COMPLETED

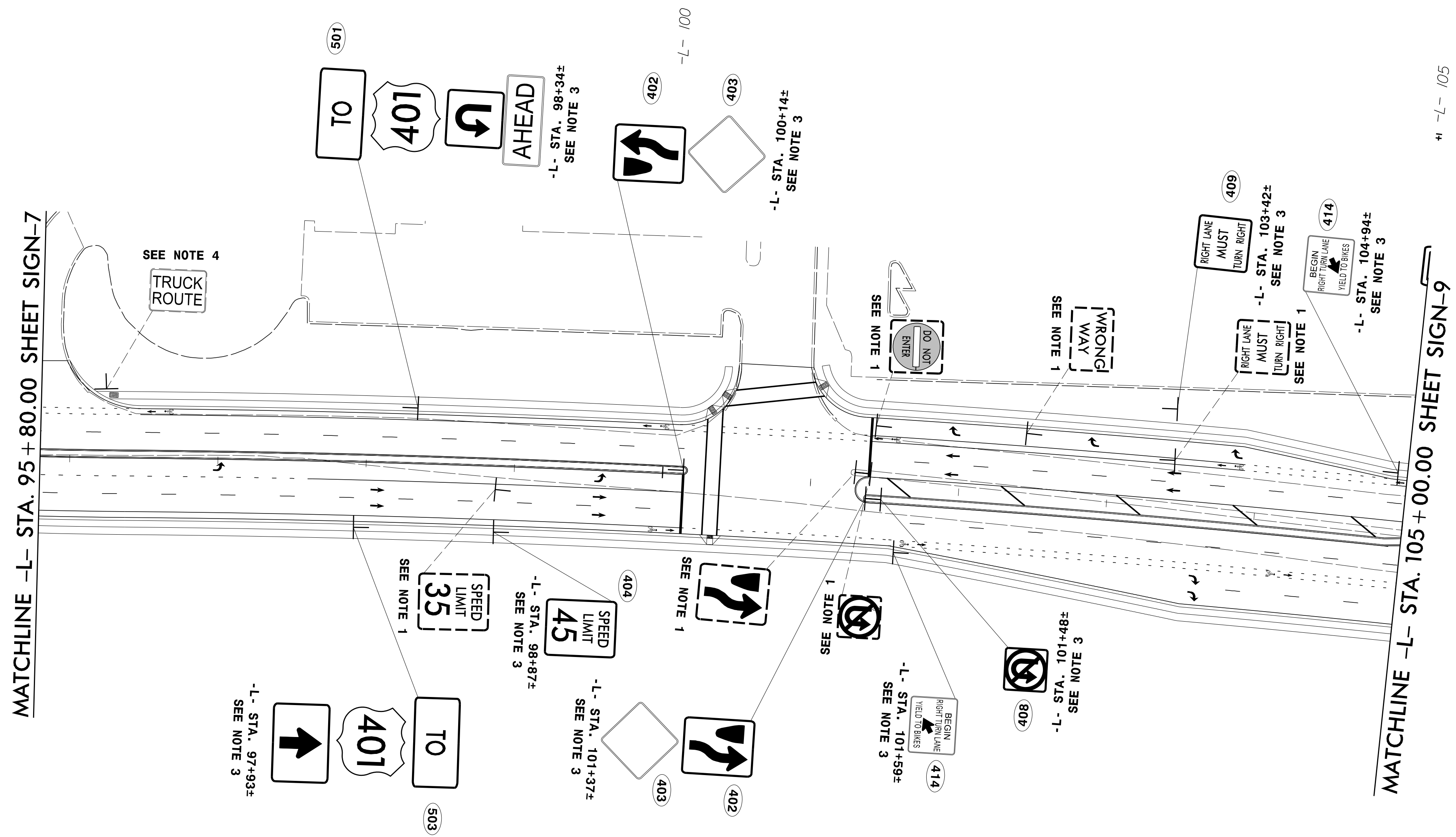
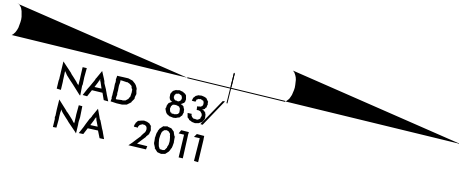

PROJECT NOTES

- 1 DISPOSAL OF SIGN SYSTEM, U-CHANNEL
- 2 SIGN ERECTION, RELOCATE SIGN TYPE D
- 3 SIGN ERECTION, TYPE D, E, AND F
- 4 EXISTING SIGN SYSTEM TO REMAIN

**PROPOSED AND
EXISTING SIGNS**

12/20/2021
 P:\Traffic\Signing\CADD\Signing Layout Plans\U5798A_sign_prop-dtl_05.dgn
 User:htclough



DOCUMENT NOT CONSIDERED FINAL UNLESS ALL SIGNATURES COMPLETED

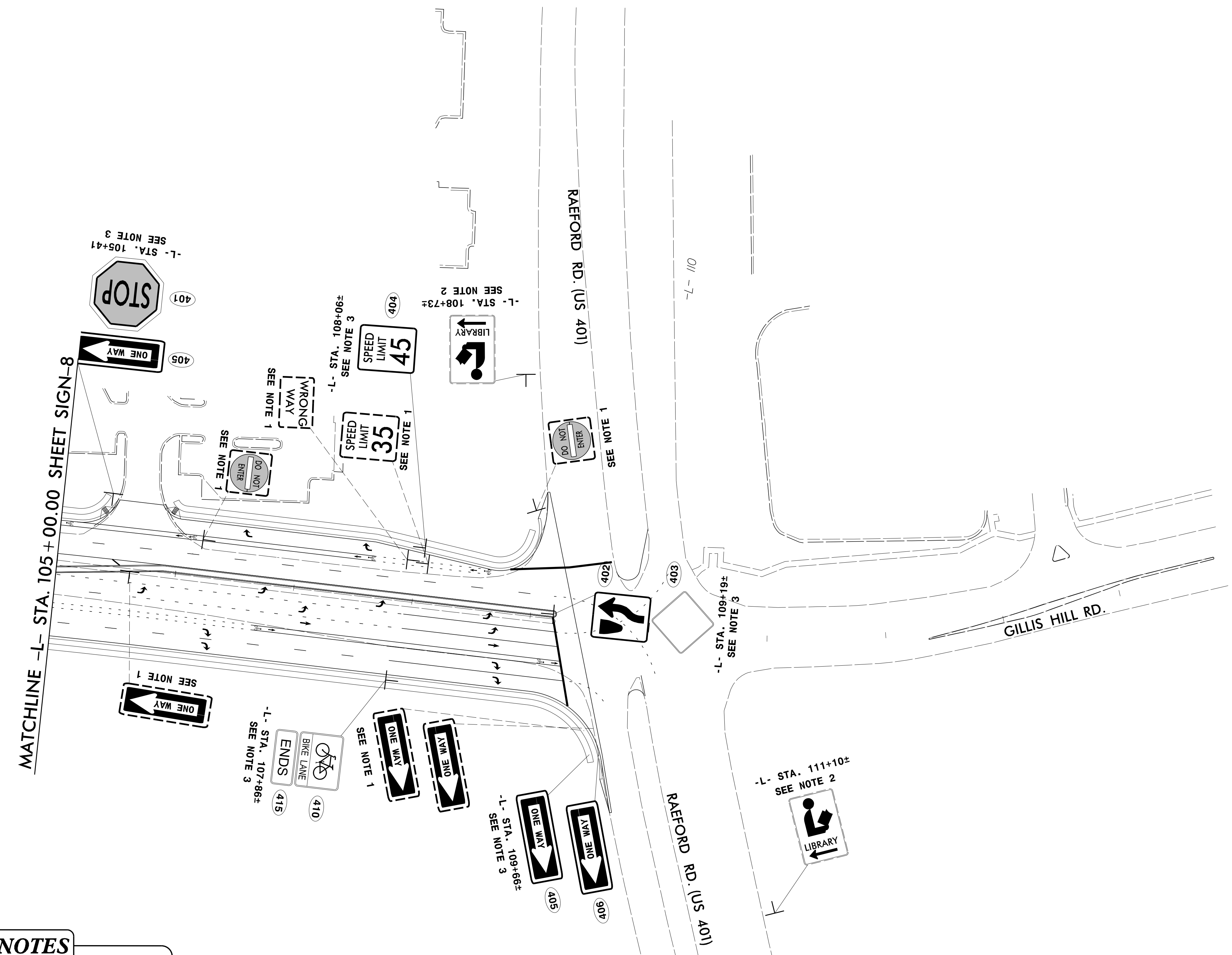
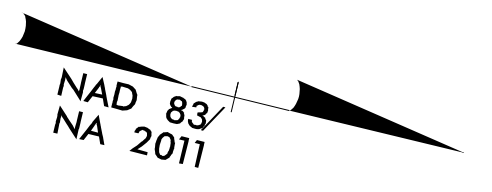

PROJECT NOTES

- 1 DISPOSAL OF SIGN SYSTEM, U-CHANNEL
- 2 SIGN ERECTION, RELOCATE SIGN TYPE D
- 3 SIGN ERECTION, TYPE D, E, AND F
- 4 EXISTING SIGN SYSTEM TO REMAIN

PROPOSED AND EXISTING SIGNS

12/20/2021
 R:\Traffic\Signing\CADD\Signing Layout Plans\U5798A_sign_prop.dtl_06.dgn
 User: jclough

