

Welded Ring Stiffened Mast Arm Connection

PROJECT ID. NO.	SHEET NO.
U-5798A	Sig.M5

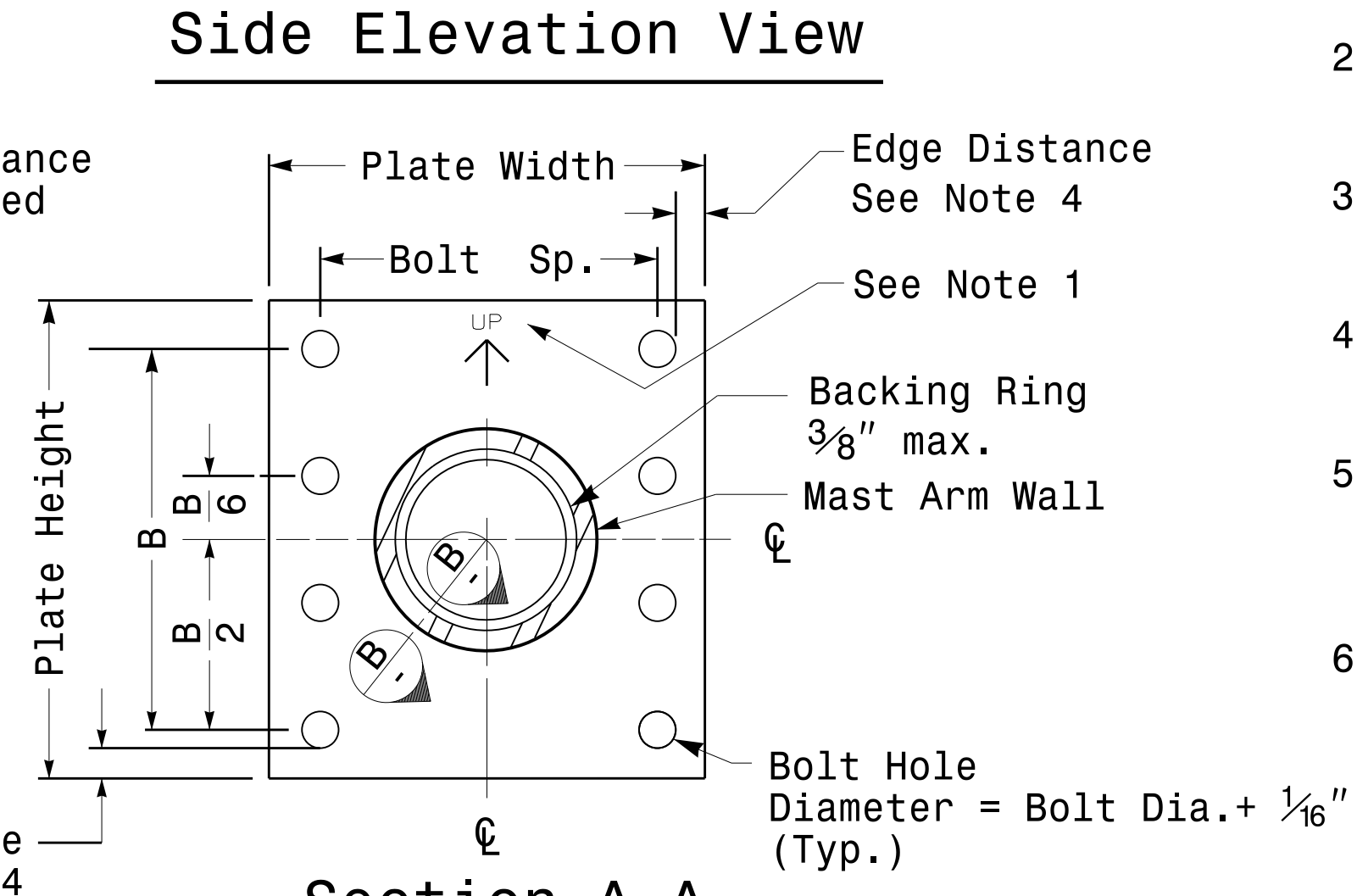
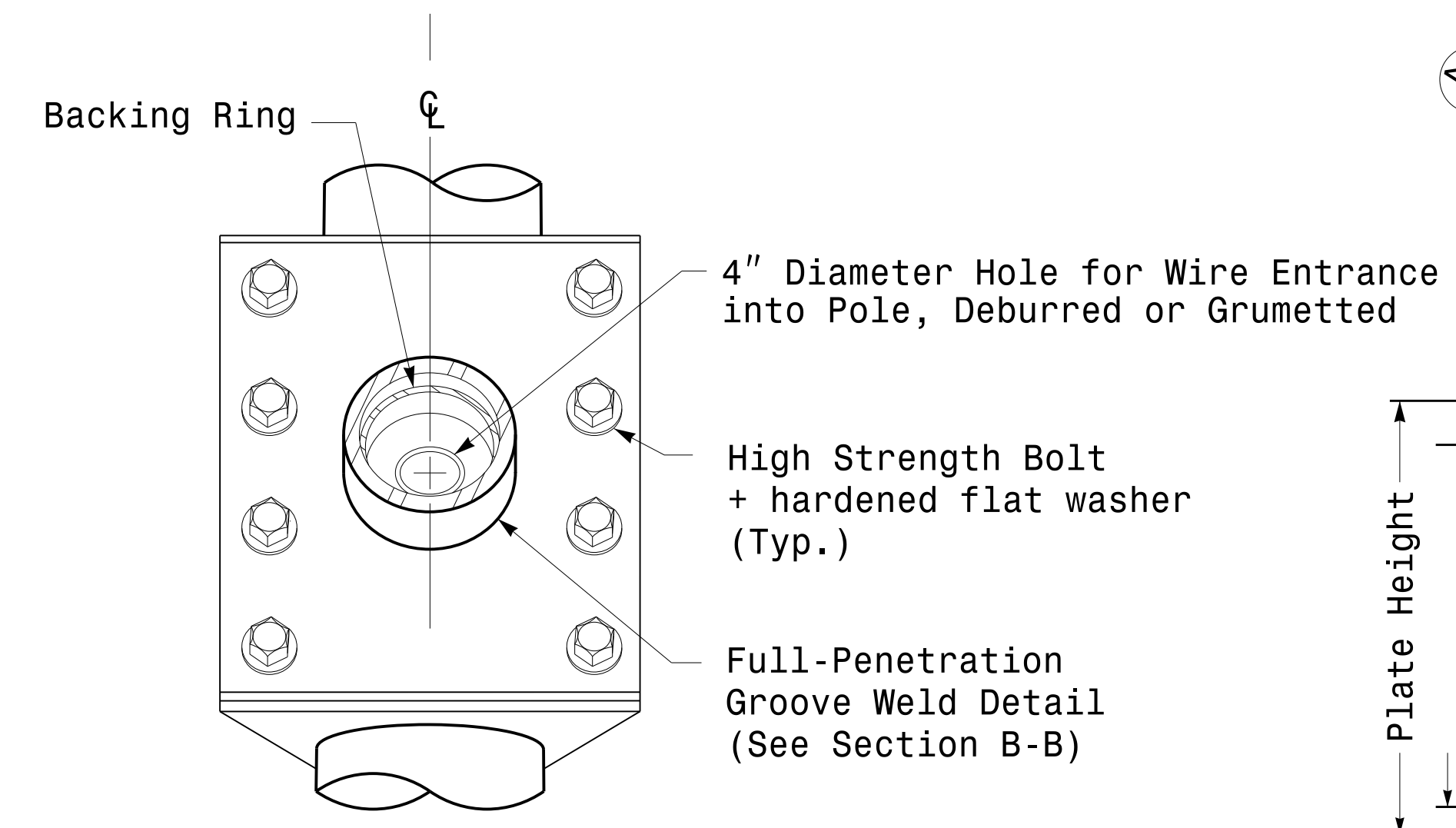
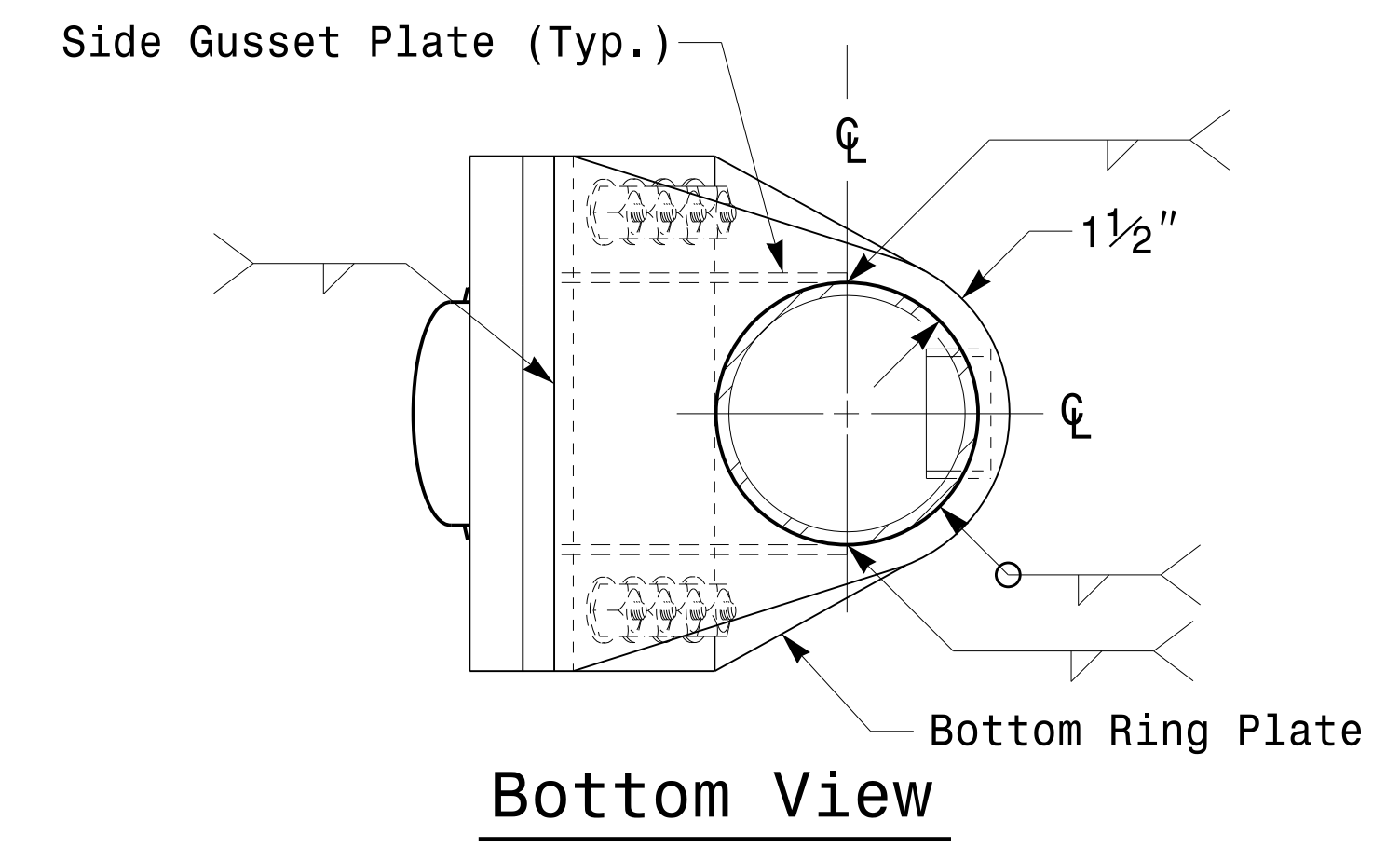
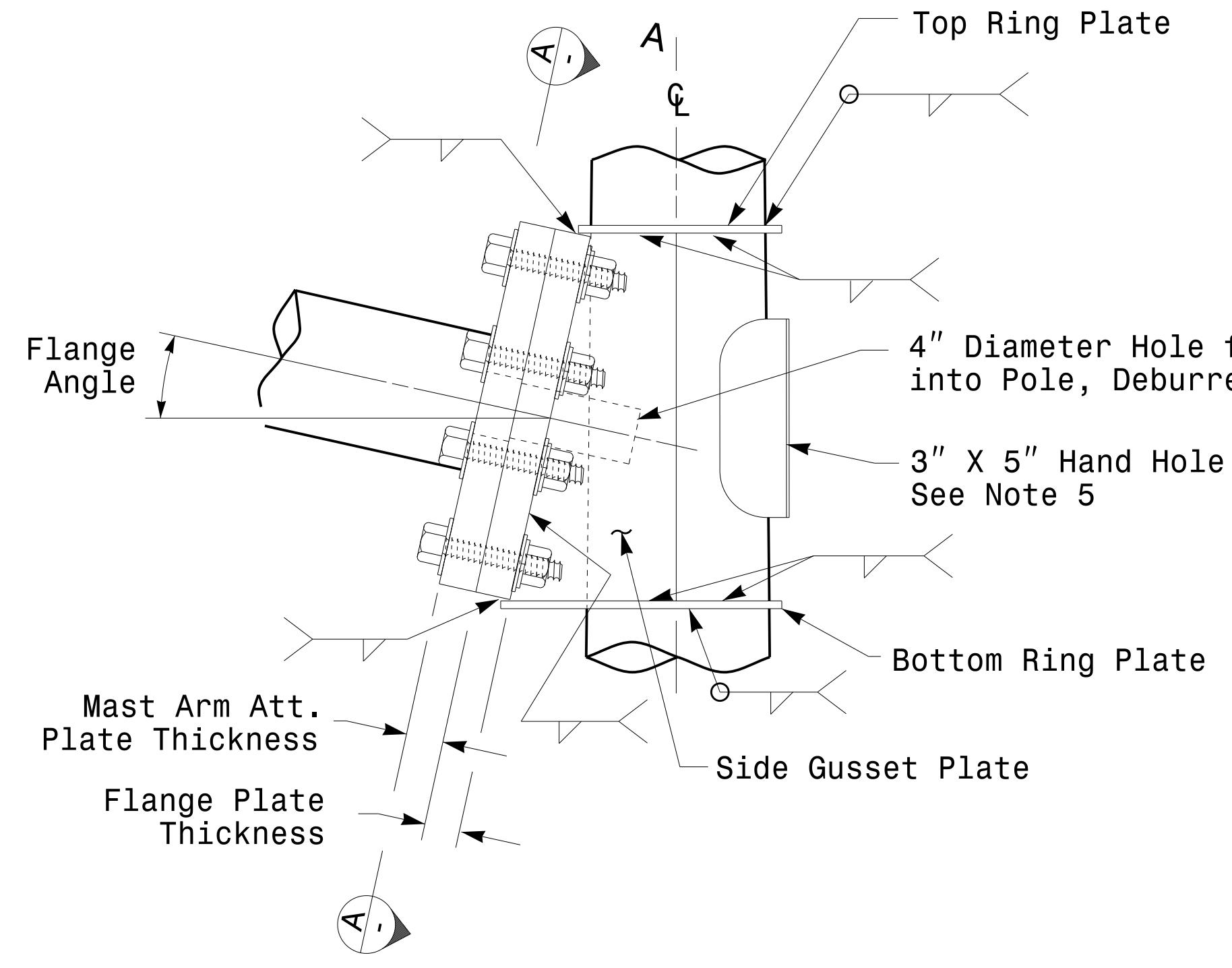
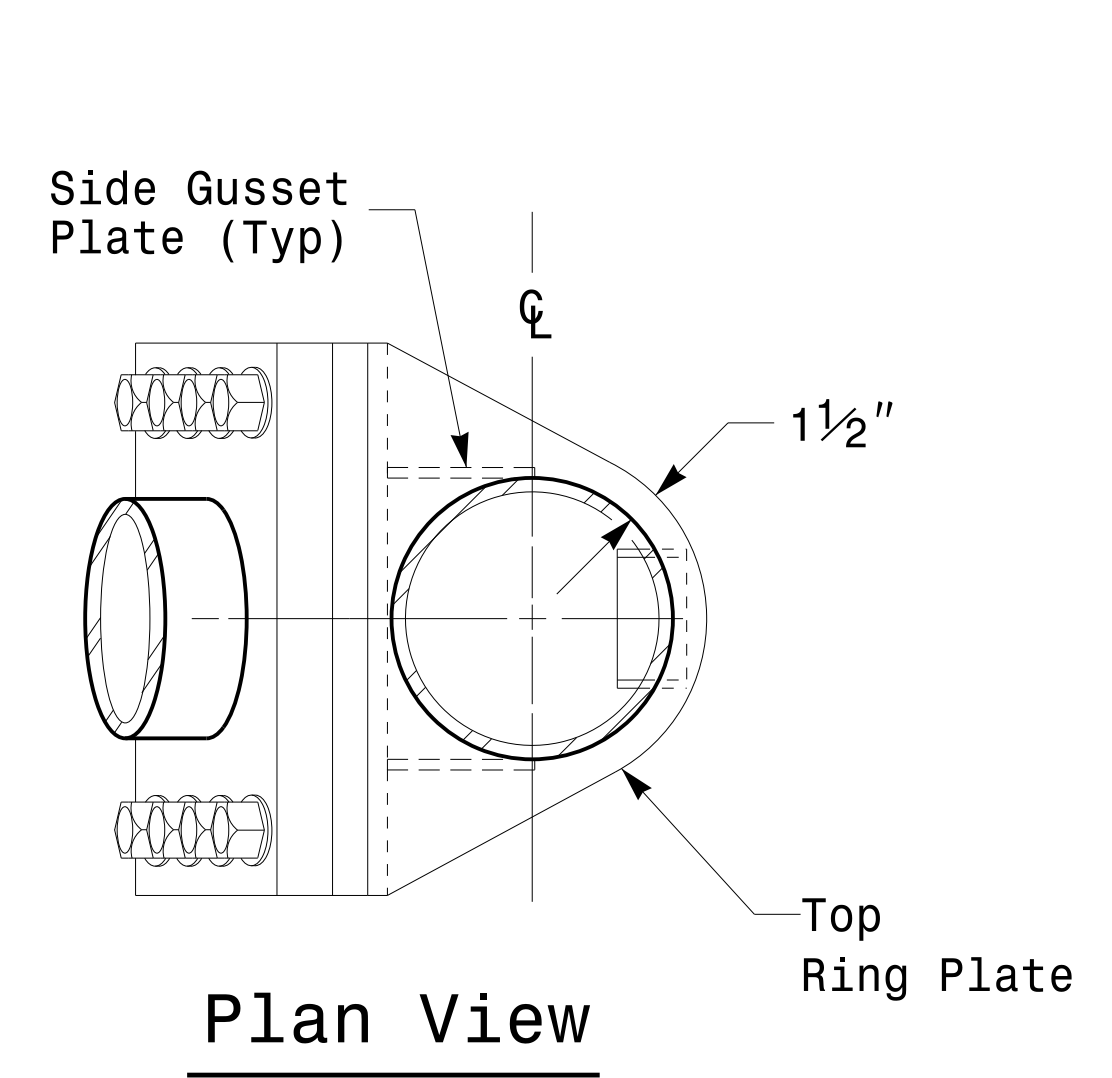

Notes:

1. Provide a permanent means of identification above the mast arm to indicate proper attachment orientation of the mast arm.
2. Designer will determine the size of all structural components, plates, fasteners, and welds shown unless they are already specified.
3. Fabricator is responsible for providing appropriate holes at drainage points to drain galvanizing materials.
4. For minimum edge distance follow AISC Table J3.4 and J3.5. For nominal bolt hole size use Table J3.3.
5. Provide upper handhole as necessary when shaft extensions are required for luminaire arms or camera. For poles without luminaires/camera, wiring can be done through the top of pole.
6. Allowable range of flange tilt angle will vary from 0° to as required.

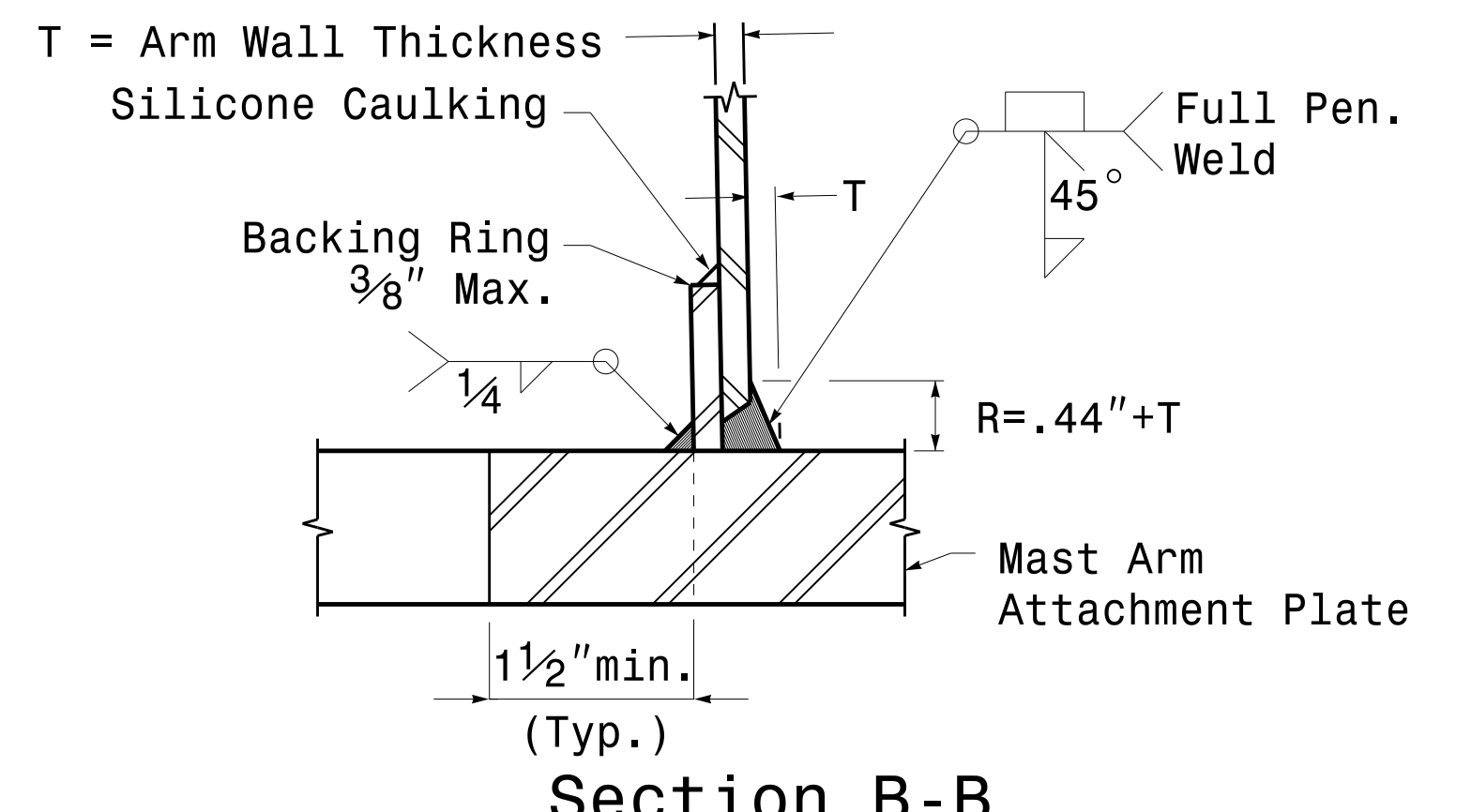
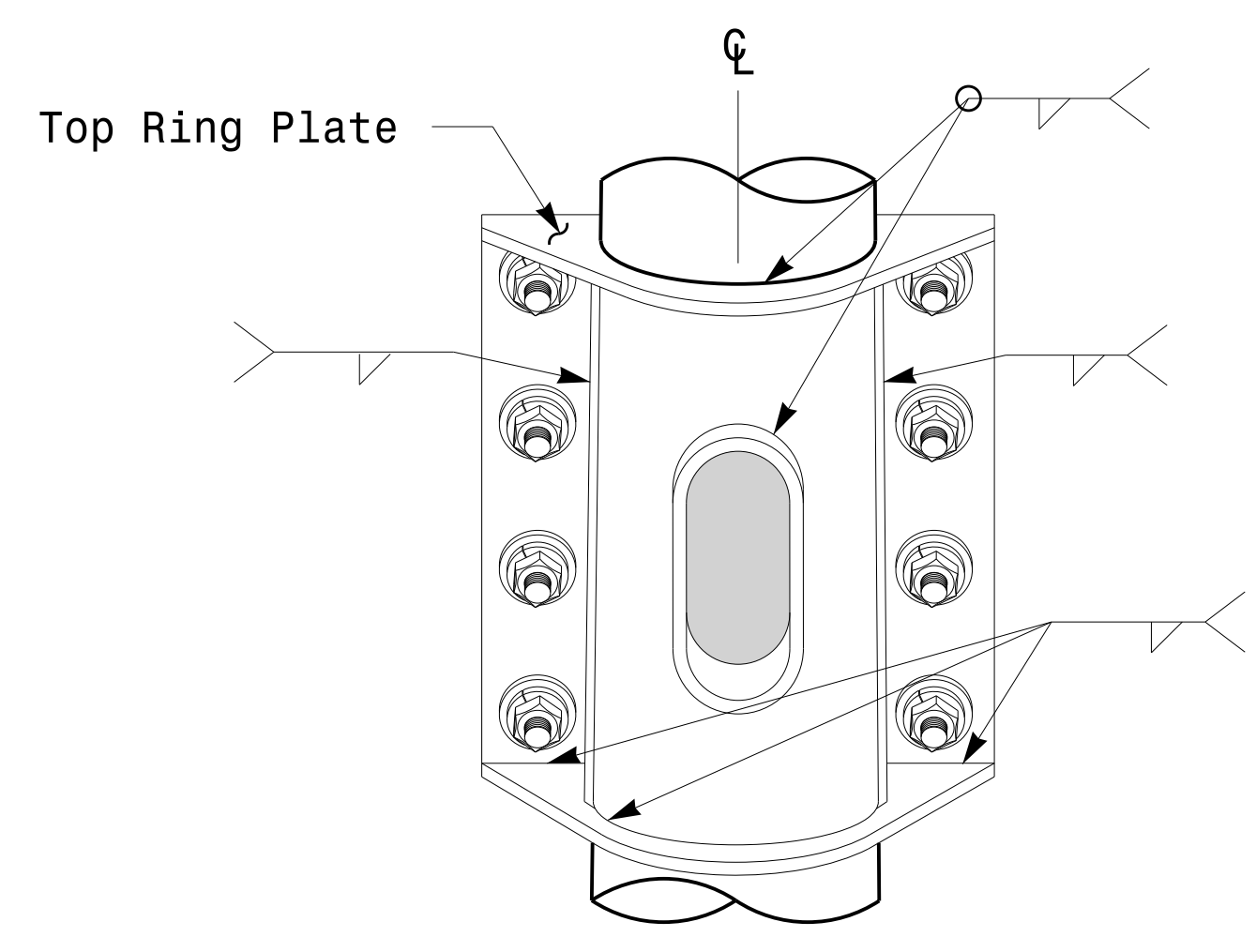

Prepared in the Offices of: 750 N. Greenfield Pkwy, Garner, NC 27529	Typical Fabrication Details For Mast Arm Connection To Pole		SEAL NORTH CAROLINA PROFESSIONAL ENGINEER 028094 DEBESH C. SARKAR
	PLAN DATE: OCTOBER 2017 PREPARED BY: N. BITTING	DESIGNED BY: C.F. ANDREWS REVIEWED BY: D.C. SARKAR	
SCALE 0 NA NONE	Disigned by: DATE: 10/11/2017		

Fabrication Details – Mast Arm Connection

11-OCT-2017 08:35 136560115 5101a1s461gnol Design Section Eastern RegionM Sheers20162014 Sig.M5 51d. Connection Fabrication Detail s-Mast Arm Poles.dgn P21