

PROJECT ID. NO.	SHEET NO.
U-5798A	Sig.M4

Note:  
 1. Opening in pole base plate shall be equal to pole base inside diameter minus 3 1/2" but shall not be less than 8 1/2".

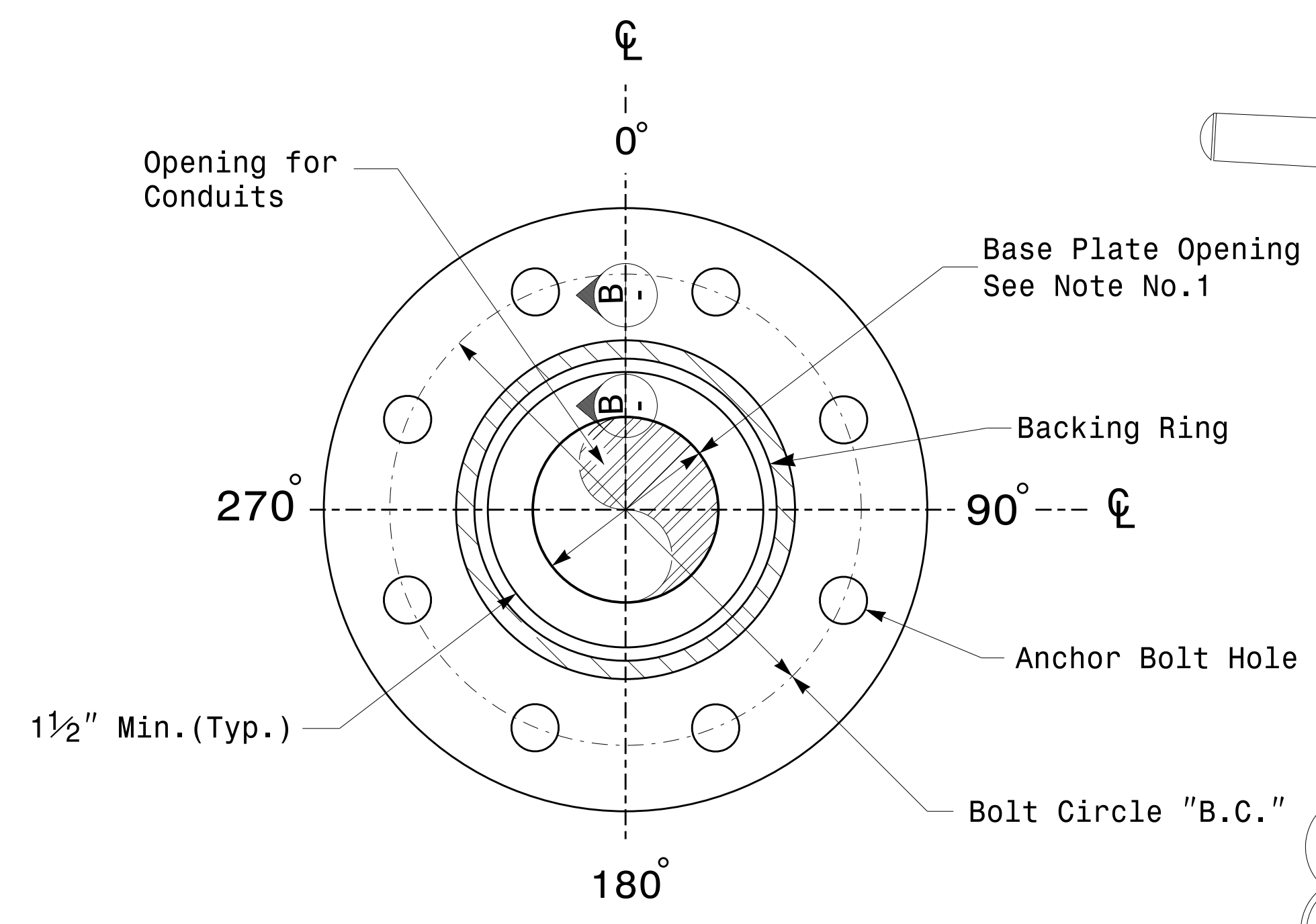

**Section A-A**  
**Pole Base Plate Details**

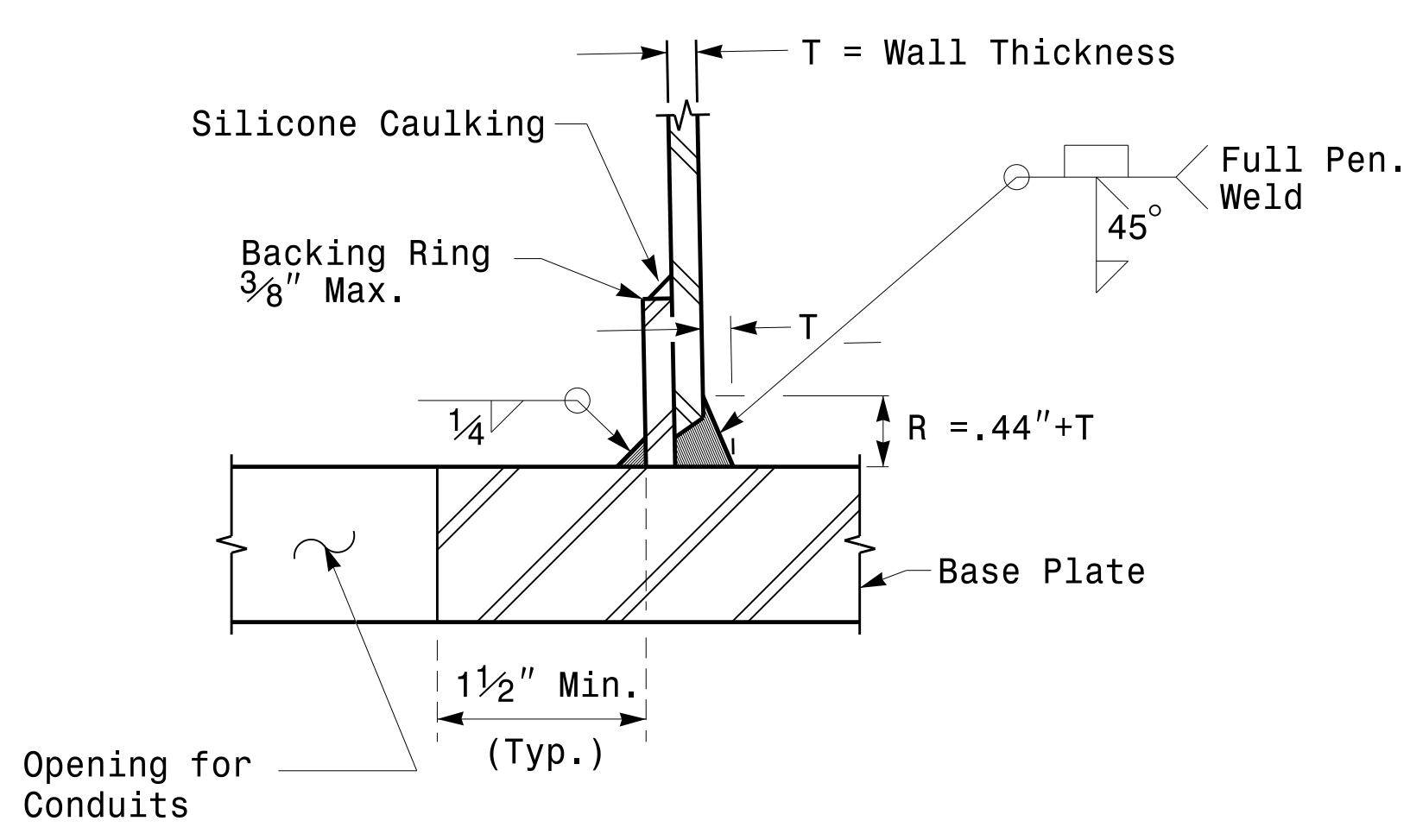

**Section B-B**  
 (Pole Attachment to Base Plate)  
**Full-Penetration Groove Weld Detail**

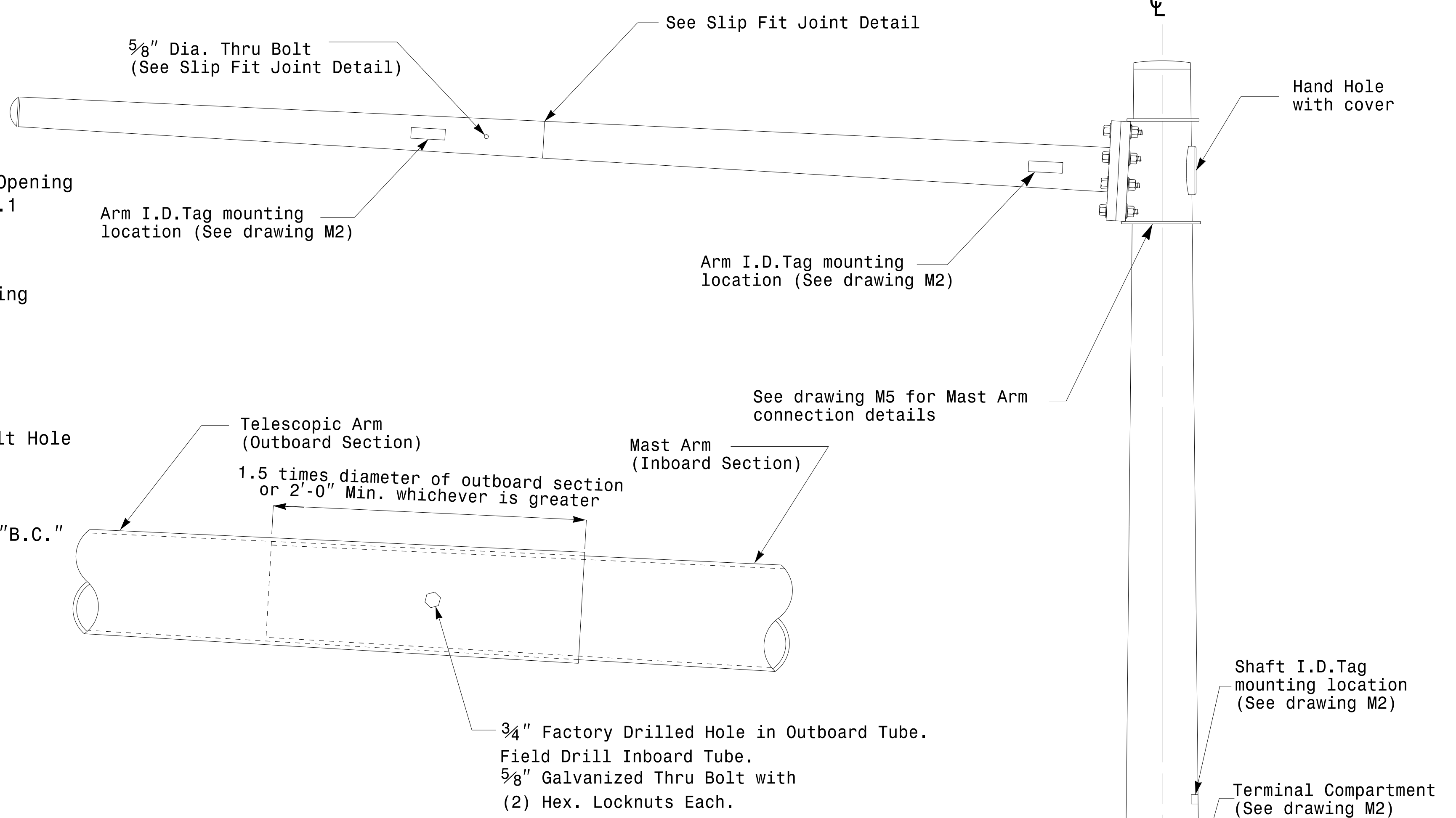

**Slip Fit Joint Detail for Mast Arm**

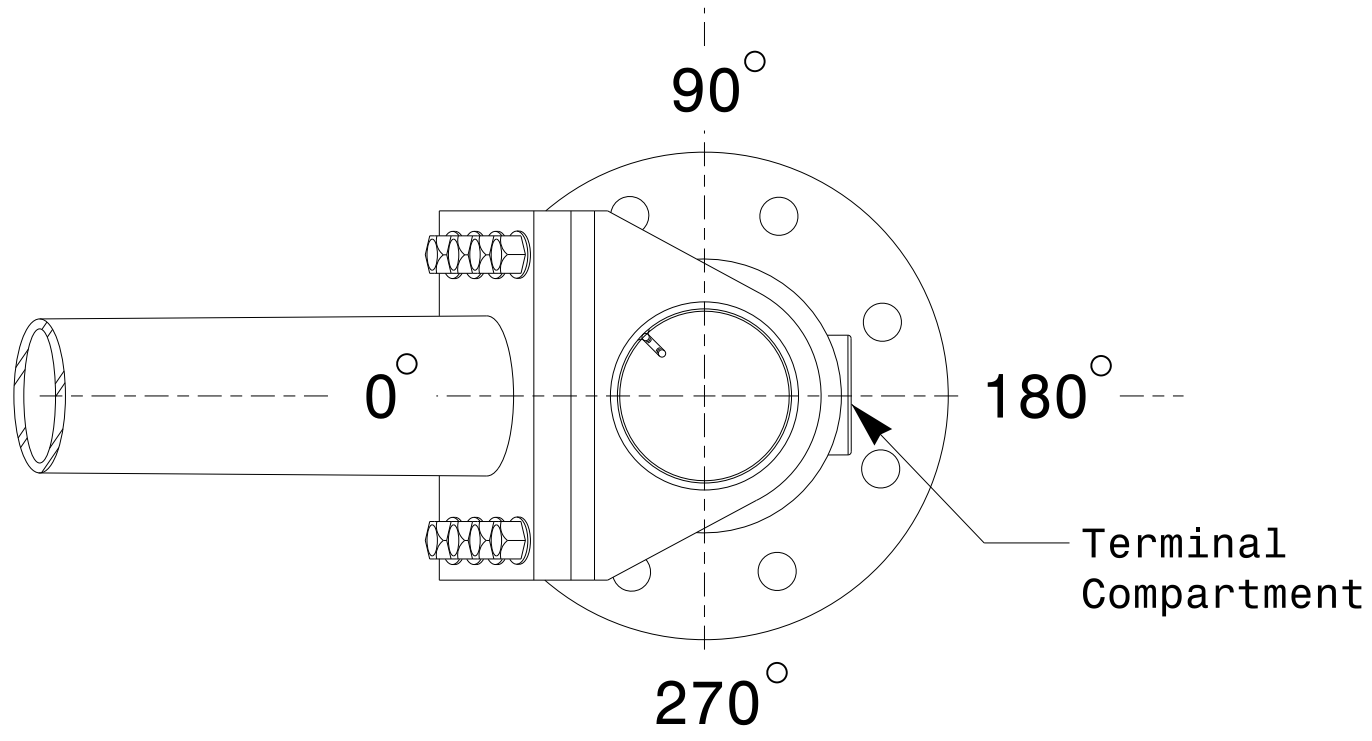

**Mast Arm Radial Orientation**

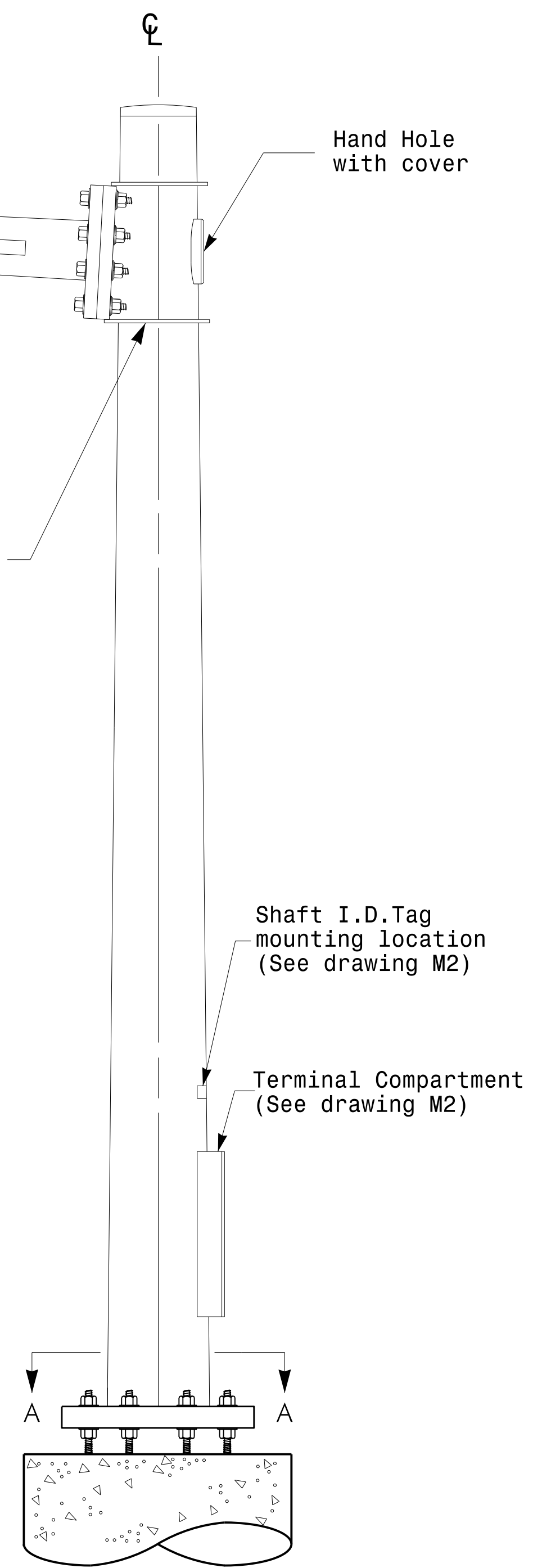

**Mast Arm Pole**

**Fabrication Details - Mast Arm Poles**

	Typical Fabrication Details For Mast Arm Poles		SEAL 
	PLAN DATE: OCTOBER 2017 PREPARED BY: N. BITTING	DESIGNED BY: K.C. DURIGON REVIEWED BY: D.C. SARKAR	
SCALE: 0 NA NONE	DocuSigned by: Dinesh C. Sarkar DATE: 10/11/2017		DATE

11-OCT-2017 08:33  
 P:\S604115\SIGNALS\Signal Design Section\Eastern Region\Sheet\2016\2014\_Sig\_M4\_Std\_Fabrication\_Details-Mast\_Arm\_Poles.dgn  
 P:\S604115\SIGNALS\Signal Design Section\Eastern Region\Sheet\2016\2014\_Sig\_M4\_Std\_Fabrication\_Details-Mast\_Arm\_Poles.dgn