

NOTES

STIRRUPS IN CAP MAY BE SHIFTED AS NECESSARY TO CLEAR ANCHOR BOLTS.

HOOKS ON "M" BARS MAY BE TURNED AS NECESSARY FOR PLACING REINFORCING STEEL.

FOR DRILLED PIERS, SEE SECTION 411 OF THE STANDARD SPECIFICATIONS.

ALL STEEL IN THE DRILLED PIERS IS INCLUDED IN THE PAY ITEMS FOR "REINFORCING STEEL" AND "SPIRAL COLUMN REINFORCING STEEL."

★INVERT ALTERNATE STIRRUPS.

THE LOCATION OF THE CONSTRUCTION JOINT IN THE DRILLED PIERS IS BASED ON AN APPROXIMATE GROUND LINE ELEVATION. IF THE CONSTRUCTION JOINT IS ABOVE THE ACTUAL GROUND LINE ELEVATION, THE CONTRACTOR SHALL PLACE THE CONSTRUCTION JOINT ONE FOOT BELOW THE GROUND LINE.

THE CONTRACTOR'S ATTENTION IS CALLED TO THE FACT THAT THE LONGITUDINAL REINFORCEMENT FOR DRILLED PIERS IS DETAILED WITH 3 FEET OF EXTRA LENGTH.

SPLICING OF THE LONGITUDINAL BARS IN DRILLED PIERS WILL NOT BE PERMITTED.

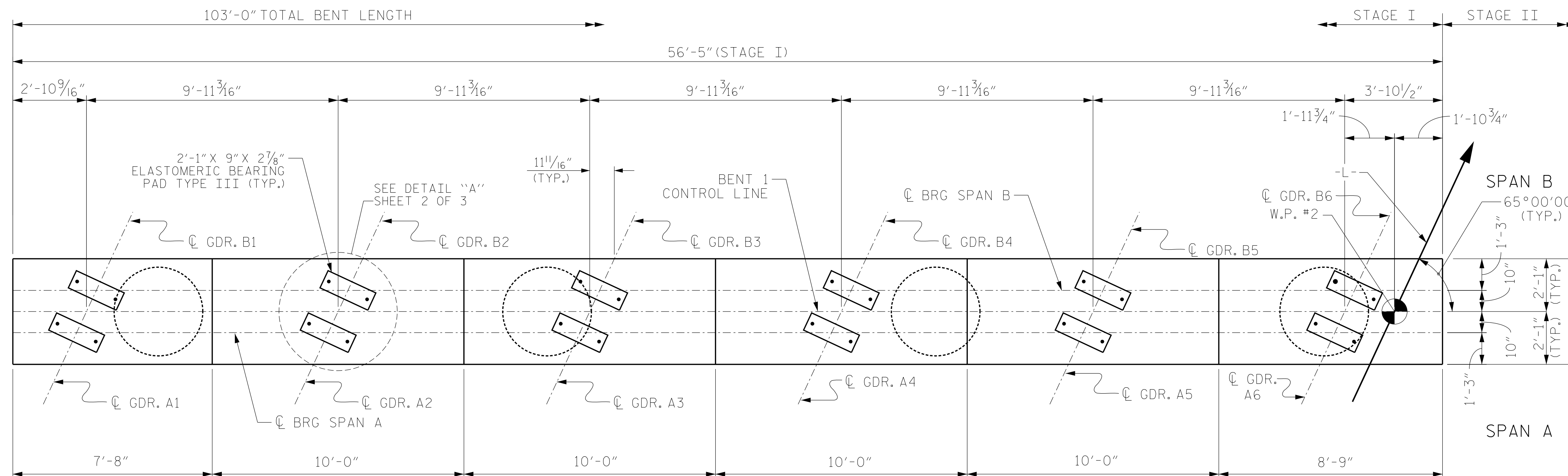

PLAN

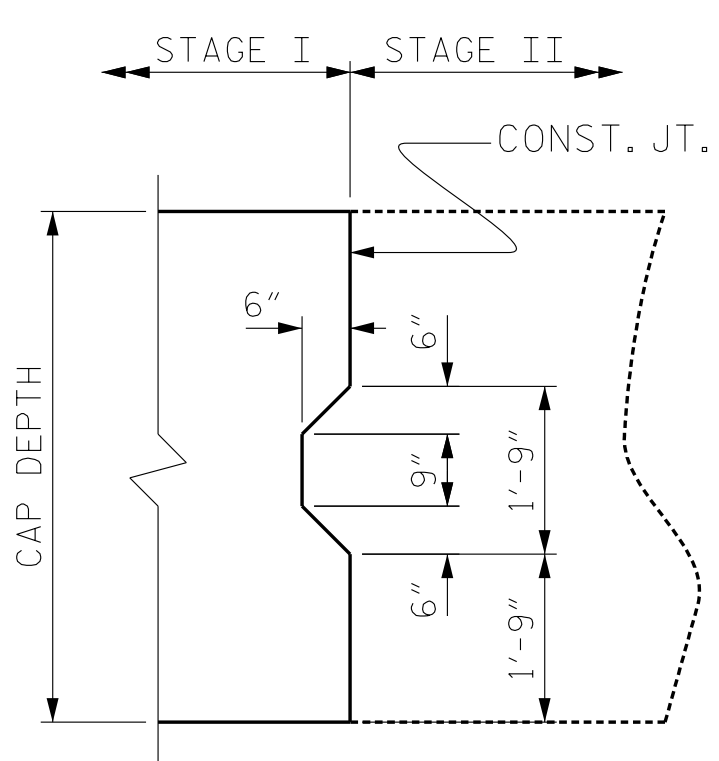

SHEAR KEY DETAIL

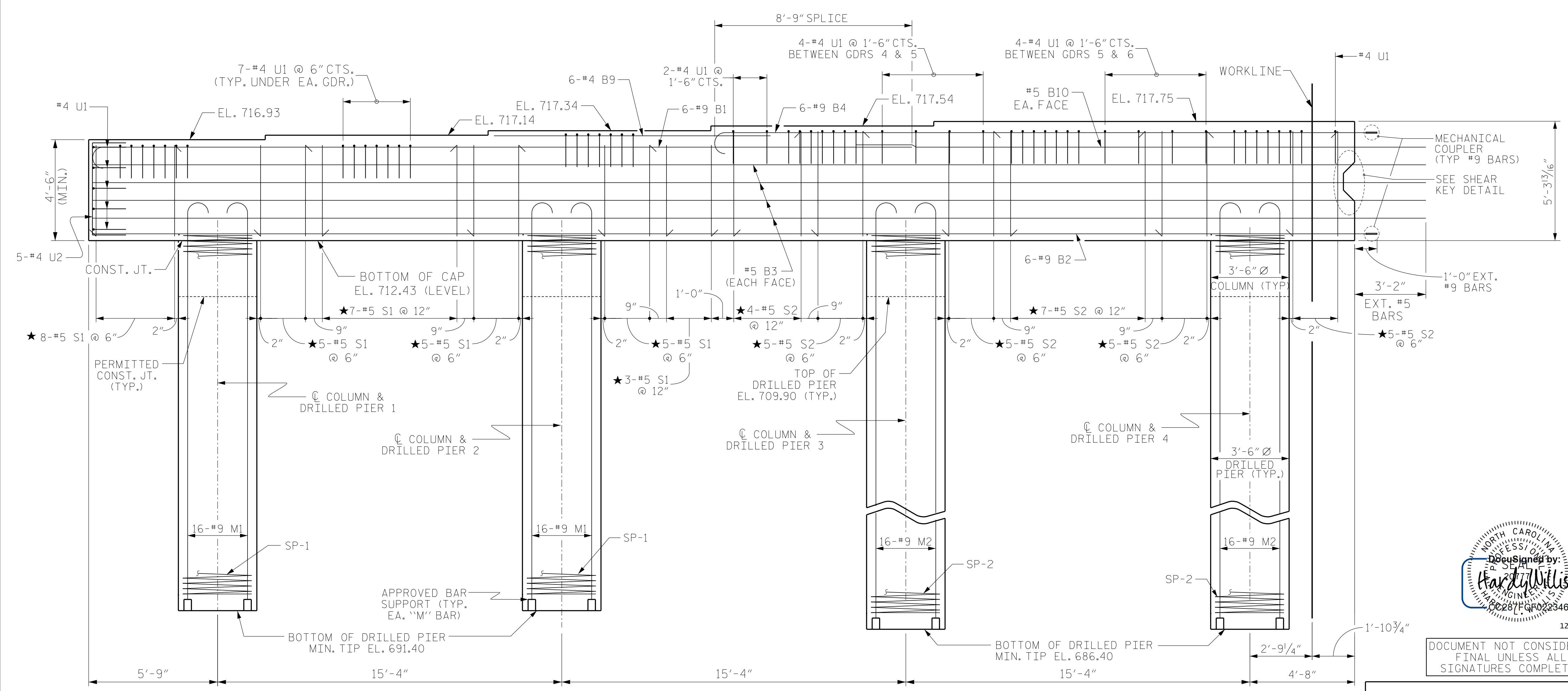

ELEVATION

DIMENSIONS & REINFORCING STEEL ARE TYPICAL FOR EACH COLUMN & DRILLED PIER UNLESS OTHERWISE NOTED.

**V&M**  
Vaughn & Melton  
Consulting Engineers

Asheville, North Carolina  
828-253-2796

Boone, NC 828-355-9933  
Tri-Cities, TN 423-467-8400  
Knoxville, TN 865-546-5800  
Spartanburg, SC 864-574-4775  
Charleston, SC 843-914-6650  
Middleburg, KY 606-248-6600  
Raleigh, NC 919-777-9455  
Charlotte, NC 704-357-0488  
Atlanta, GA 770-627-3509

Copyright © 2006 Vaughn & Melton, Inc. All Rights Reserved

PROJECT NO. U-5738

ROWAN COUNTY

STATION: 70+72.50 -L-

SHEET 1 OF 3

STATE OF NORTH CAROLINA  
DEPARTMENT OF TRANSPORTATION  
RALEIGH

SUBSTRUCTURE

BENT 1  
STAGE I

DESIGNED BY  
*Harold Willis*  
REGISTERED PROFESSIONAL ENGINEER  
No. 28716 License No. 34611...  
12/20/2021

DOCUMENT NOT CONSIDERED FINAL UNLESS ALL SIGNATURES COMPLETED

DWN. BY: FRJ	DATE: 11/18
CHKD. BY: CDB	DATE: 11/18
DES. EGR. OF RECORD: CDB	DATE: 11/18

REVISIONS						SHEET NO. S-28
NO.	BY:	DATE:	NO.	BY:	DATE:	
1			3			TOTAL SHEETS 39
2			4			