

TYPICAL END BENT OR BENT DIAPHRAGM (D1)

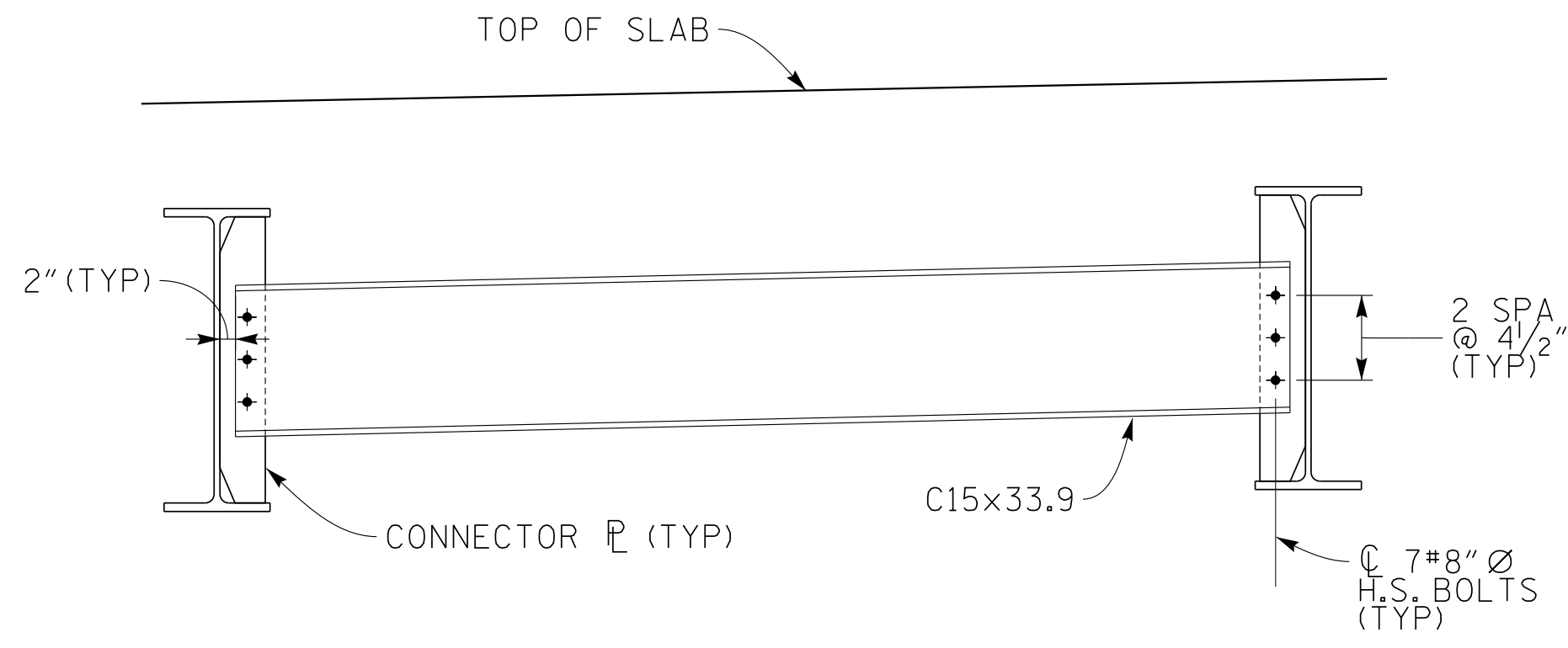

TYPICAL INTERMEDIATE DIAPHRAGM (D2)

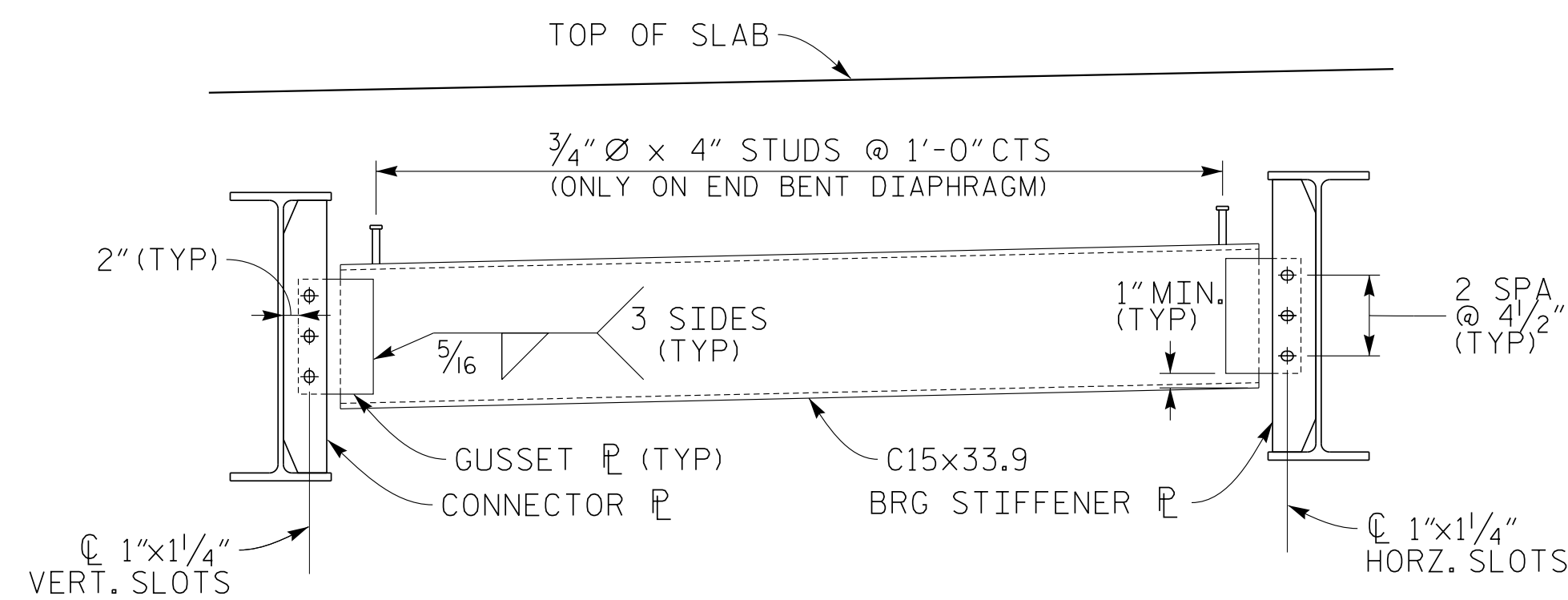

END BENT OR BENT DIAPHRAGM (D4)
IN CLOSURE BAY

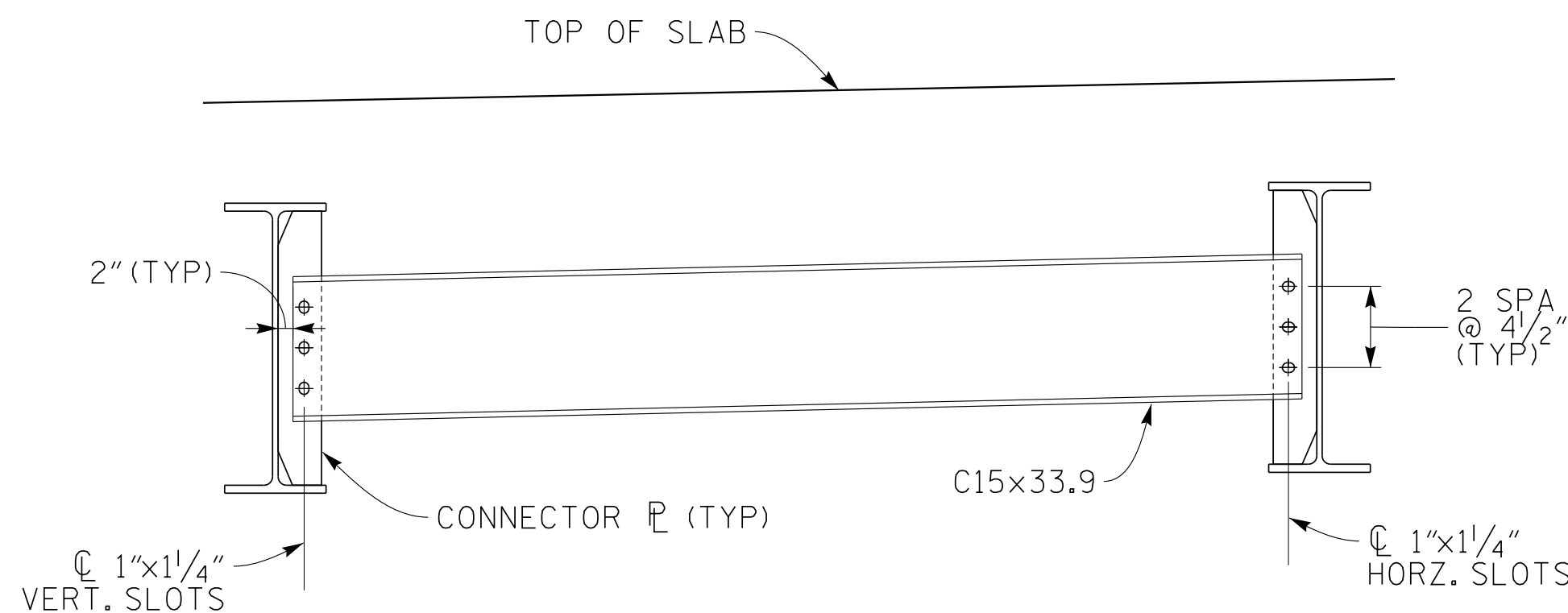

INTERMEDIATE DIAPHRAGM (D3)
IN CLOSURE BAY

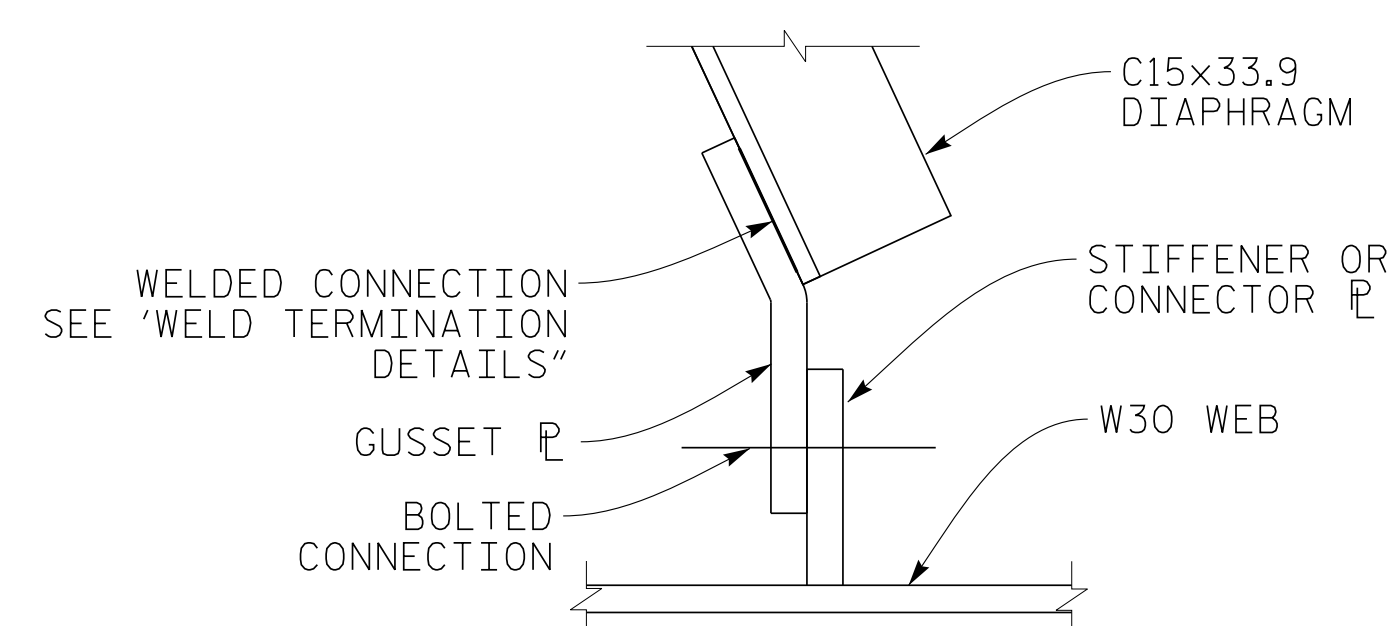

STIFFENER/CONNECTOR TO GUSSET DETAIL

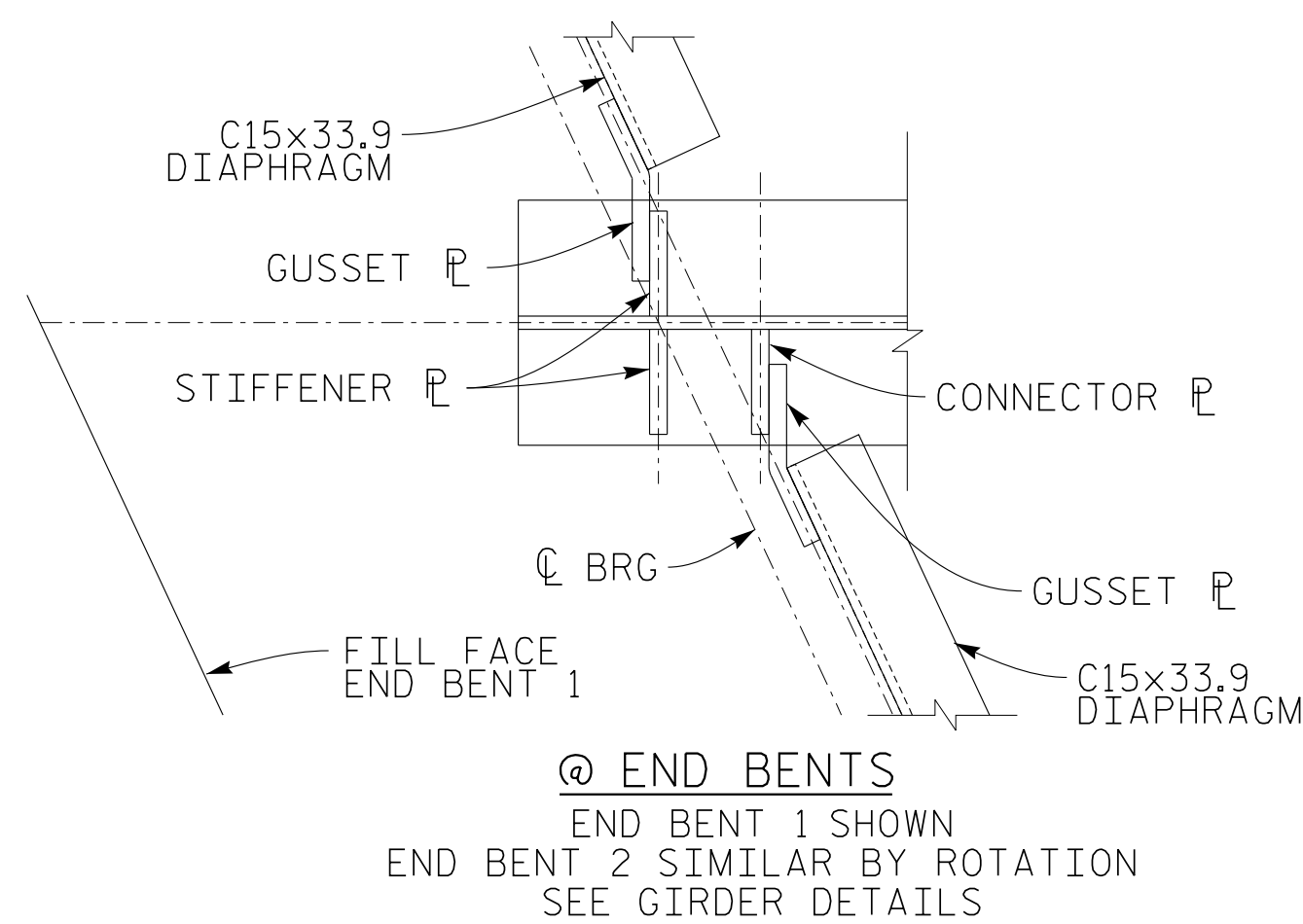

DIAPHRAGM CONNECTION DETAILS

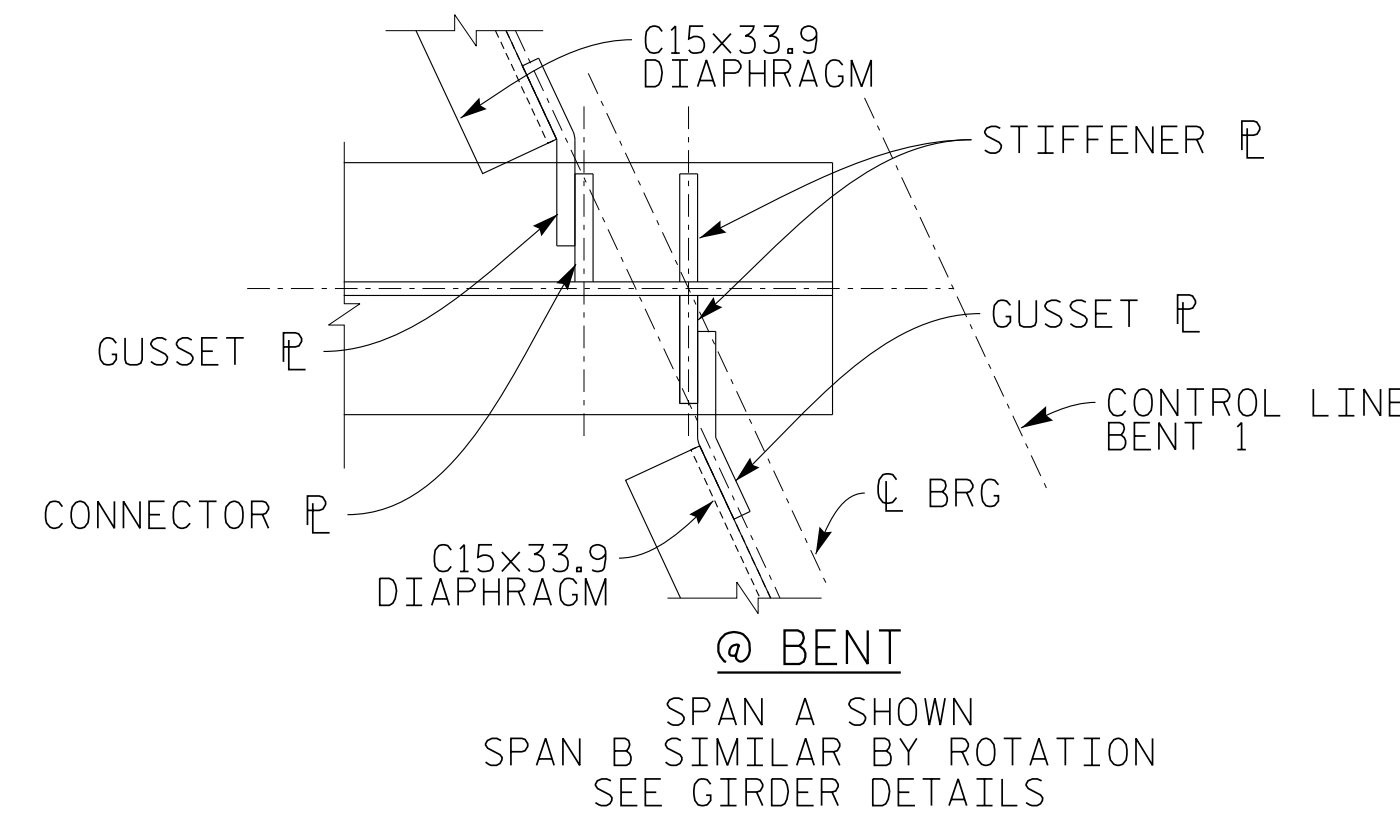

V&M
Vaughn & Melton
Consulting Engineers
Asheville, North Carolina
828-253-2796

- Boone, NC 828-355-9933
- Tri-Cities, TN 423-467-8401
- Knoxville, TN 865-546-5800
- Spartanburg, SC 864-574-4775
- Charleston, SC 843-974-5650
- Middlesboro, KY 606-248-5600
- Raleigh, NC 919-977-9455
- Charlotte, NC 704-357-0488
- Atlanta, GA 770-627-3509

Copyright © 2006 Vaughn & Melton, Inc. All Rights Reserved



12/13/2021

NOTES

ALL STRUCTURAL STEEL SHALL BE AASHTO M270 GRADE 50W AND PAINTED IN ACCORDANCE WITH SYSTEM 5 OR SYSTEM 6 OF THE STRUCTURAL STEEL SHOP COATINGS PROGRAM AND SECTION 442-8 OF THE STANDARD SPECIFICATIONS UNLESS OTHERWISE NOTED ON THE PLANS.

STIFFENERS ARE NOT REQUIRED ON THE OUTSIDE OF EXTERIOR BEAMS.

ALL DIMENSIONS ARE HORIZONTAL OR VERTICAL UNLESS OTHERWISE NOTED. ALL BOLTED FIELD CONNECTIONS SHALL BE 7/8" Ø HIGH STRENGTH BOLTS, UNLESS OTHERWISE NOTED.

BEARING STIFFENERS ARE TO BE PLACED NORMAL TO THE WEB OF THE GIRDER AND SHALL BE PLUMB.

NUTS ON BOLTS FOR CONNECTING DIAPHRAGMS TO CONNECTOR PLATE SHALL BE LEFT LOOSE FOR PURPOSE OF ADJUSTMENT UNTIL BOTH SIDES OF SLAB IN CLOSURE BAY HAVE BEEN POURED.

A CHARPY V-NOTCH TEST IS REQUIRED ON ALL BEAM SECTIONS AS SHOWN ON THE PLANS AND IN ACCORDANCE WITH ARTICLE 1072-7 OF THE STANDARD SPECIFICATIONS.

ENDS OF ALL GIRDERS SHALL BE PLUMB.

FABRICATORS SHALL DETAIL DIAPHRAGM MEMBERS AND CONNECTIONS FOR FULL DEAD LOAD FIT UP. GIRDERS SHALL BE PLUMB AFTER THE FULL AMOUNT OF DEAD LOAD IS APPLIED.

FOR WELD SIZE AND WELD TERMINATION DETAILS, SEE SHEET S-15

PROJECT NO. U-5738

ROWAN COUNTY

STATION: 70+72.50 -L-

SHEET 2 OF 3

STATE OF NORTH CAROLINA
DEPARTMENT OF TRANSPORTATION
RALEIGH
SUPERSTRUCTURE
STRUCTURAL STEEL
DETAILS

DOCUMENT NOT CONSIDERED
FINAL UNLESS ALL
SIGNATURES COMPLETED

DWN. BY: FRJ DATE: 11/18
CHKD. BY: CDB DATE: 11/18
DES. EGR. OF RECORD: CDB DATE: 11/18

REVISIONS						SHEET NO.	
NO.	BY:	DATE:	NO.	BY:	DATE:	S-14	
1			3			TOTAL SHEETS	
2			4			39	