

PHASING DIAGRAM

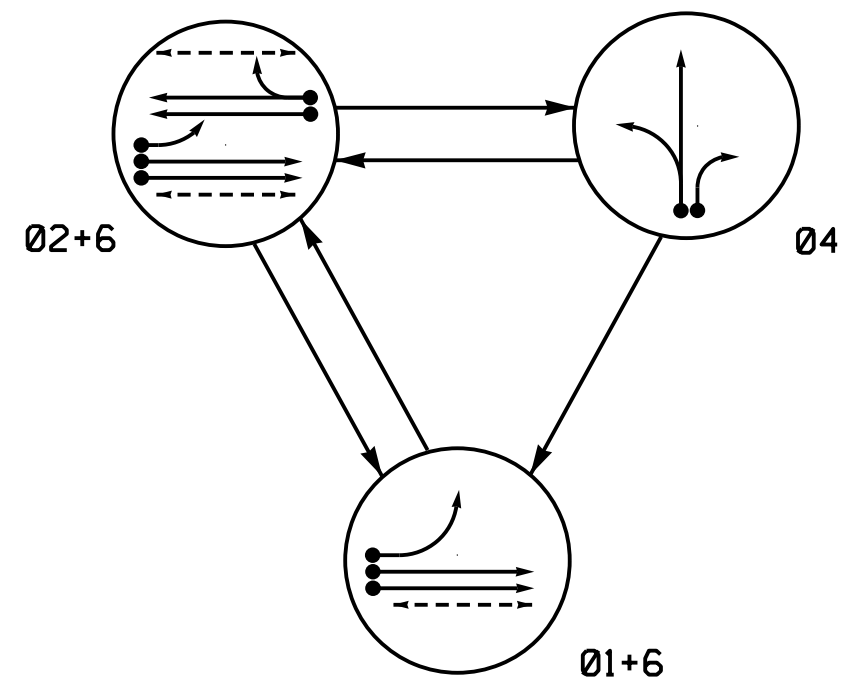

SIGNAL FACE	PHASE			
	Ø 1 + 6	Ø 2 + 6	Ø 4	FLASH
11	-	-	-	-
21,22	R	G	R	Y
41,42	R	R	G	R
61,62	↑	↑	R	Y
P21,P22	DW	W	DW	DRK
P61,P62	W	W	DW	DRK

SIGNAL FACE I.D.

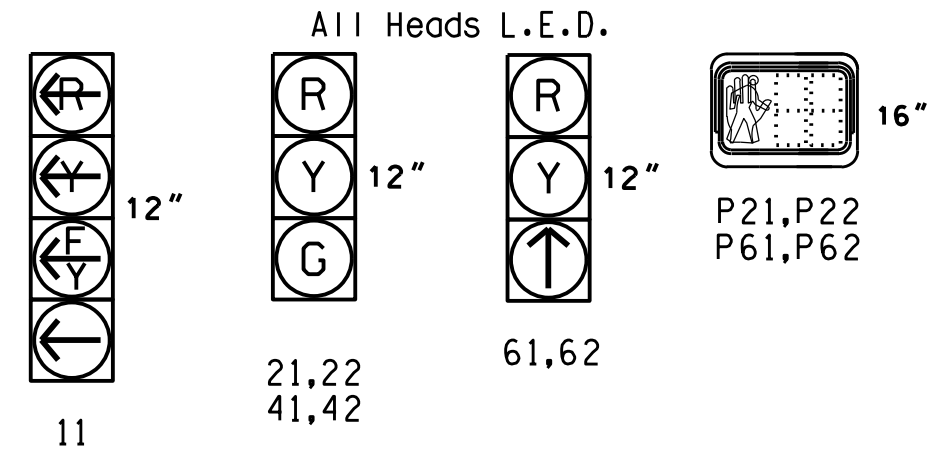

PHASING DIAGRAM DETECTION LEGEND

- ←● DETECTED MOVEMENT
- ← UNDETECTED MOVEMENT (OVERLAP)
- UNSIGNALIZED MOVEMENT
- PEDESTRIAN MOVEMENT

ASC/3 DETECTOR INSTALLATION CHART											
DETECTOR				PROGRAMMING							
ZONE	SIZE (FT)	DISTANCE FROM STOPBAR (FT)	TURNS	NEW LOOP	PHASE	CALLING	EXTEND TIME	DELAY TIME	USE ADDED INITIAL	TYPE	NEW CARD
1A*	6X40	0	*	*	1	Yes	-	15	-	S	*
2A*	6X6	70	*	*	2	Yes	-	-	-	S	*
2B*	6X6	70	*	*	2	Yes	-	-	-	S	*
4A*	6X40	0	*	*	4	Yes	-	-	-	S	*
4B*	6X40	0	*	*	4	Yes	-	15	-	S	*
6A*	6X6	70	*	*	6	Yes	-	-	-	S	*
6B*	6X6	70	*	*	6	Yes	-	-	-	S	*

* Video Detection

3 Phase Fully Actuated (High Point Signal System)

NOTES

- Refer to "Roadway Standard Drawings NCDOT" dated January 2018 and "Standard Specifications for Roads and Structures" dated January 2018.
- Do not program signal for late night flashing operation unless otherwise directed by the Engineer.
- Phase 1 may be lagged.
- Reposition existing signal heads numbered 21 and 22.
- Set all detector units to presence mode.
- Omit "WALK" and flashing "DON'T WALK" with no pedestrian calls.
- Program pedestrian heads to countdown the flashing "Don't Walk" time only.
- This intersection uses video detection, install according to manufacturer's instructions to achieve the desired detections.
- Maximum times shown in timing chart are for free-run operation only. Coordinated signal system timing values supersede these values.
- All metal poles, mastarms, and pedestrian pedestals shall be black power coated and fluted design approved by City of High Point. Refer to the Project Special Provisions for details.

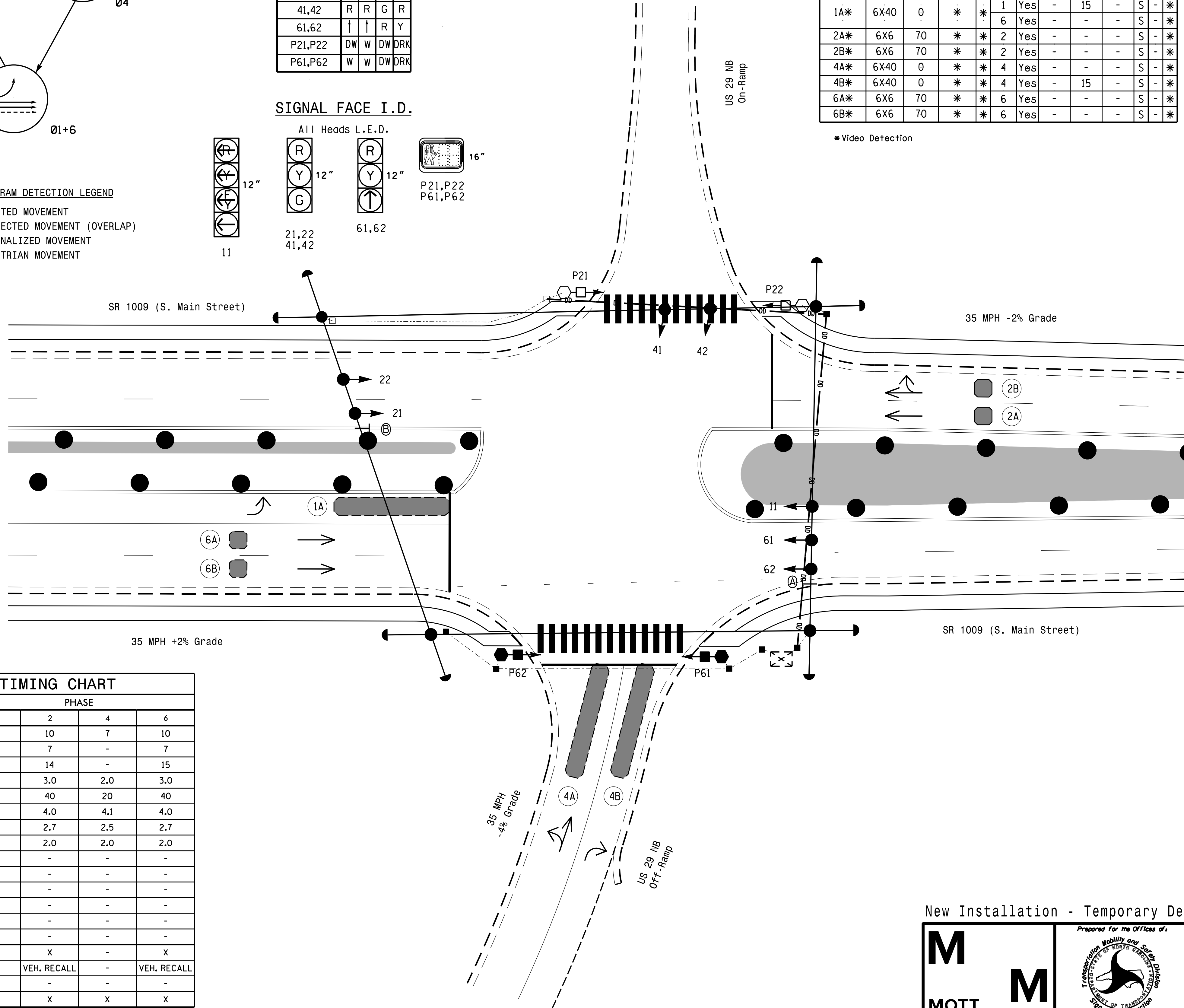

FEATURE	PHASE			
	1	2	4	6
Min Green *	7	10	7	10
Walk *	-	7	-	7
Ped Clear	-	14	-	15
Veh. Extension *	2.0	3.0	2.0	3.0
Max I *	20	40	20	40
Yellow	3.0	4.0	4.1	4.0
Red Clear	3.4	2.7	2.5	2.7
Red Revert	2.0	2.0	2.0	2.0
Actuations B4 Add *	-	-	-	-
Seconds / Actuation *	-	-	-	-
Max Initial *	-	-	-	-
Time Before Reduction *	-	-	-	-
Time To Reduce *	-	-	-	-
Minimum Gap	-	-	-	-
Locking Detector	-	X	-	X
Recall Position	-	VEH. RECALL	-	VEH. RECALL
Dual Entry	-	-	-	-
Simultaneous Gap	X	X	X	X

* These values may be field adjusted. Do not adjust Min Green and Extension times for phases 2 and 6 lower than what is shown. Min Green for all other phases should not be lower than 4 seconds.

LEGEND

- | PROPOSED | EXISTING |
|----------|----------|
| | |
| | N/A |
| | |
| | |
| | |
| | |
| | |
| | |
| | |
| | |
| | N/A |
| | |
| | |
| | |
| | |
| | |
| | |
| | |
| | |

New Installation - Temporary Design 4 (TMP Phase VI)

DOCUMENT NOT CONSIDERED FINAL UNLESS ALL SIGNATURES COMPLETED

MOTT MACDONALD
7621 Purfoy Road
Suite 115
Fuquay-Varina, NC 27526
www.mottmac.com
License No. F-0669

750 N. Greenfield Hwy, Corner, NC 27529
SCALE
0 20
1"=20'

SR 1009 (S. Main Street) at US 29 NB Ramps
Division 7 Guilford County High Point
PLAN DATE: May 2021 REVIEWED BY: RW Thompson
PREPARED BY: DE Fowler REVIEWED BY:
REVISIONS INIT. DATE

SEAL
NORTH CAROLINA PROFESSIONAL ENGINEER
SEAL 045256
Brendan A. Lehman
SIGNATURE DATE