

BENT CAP REPAIRS

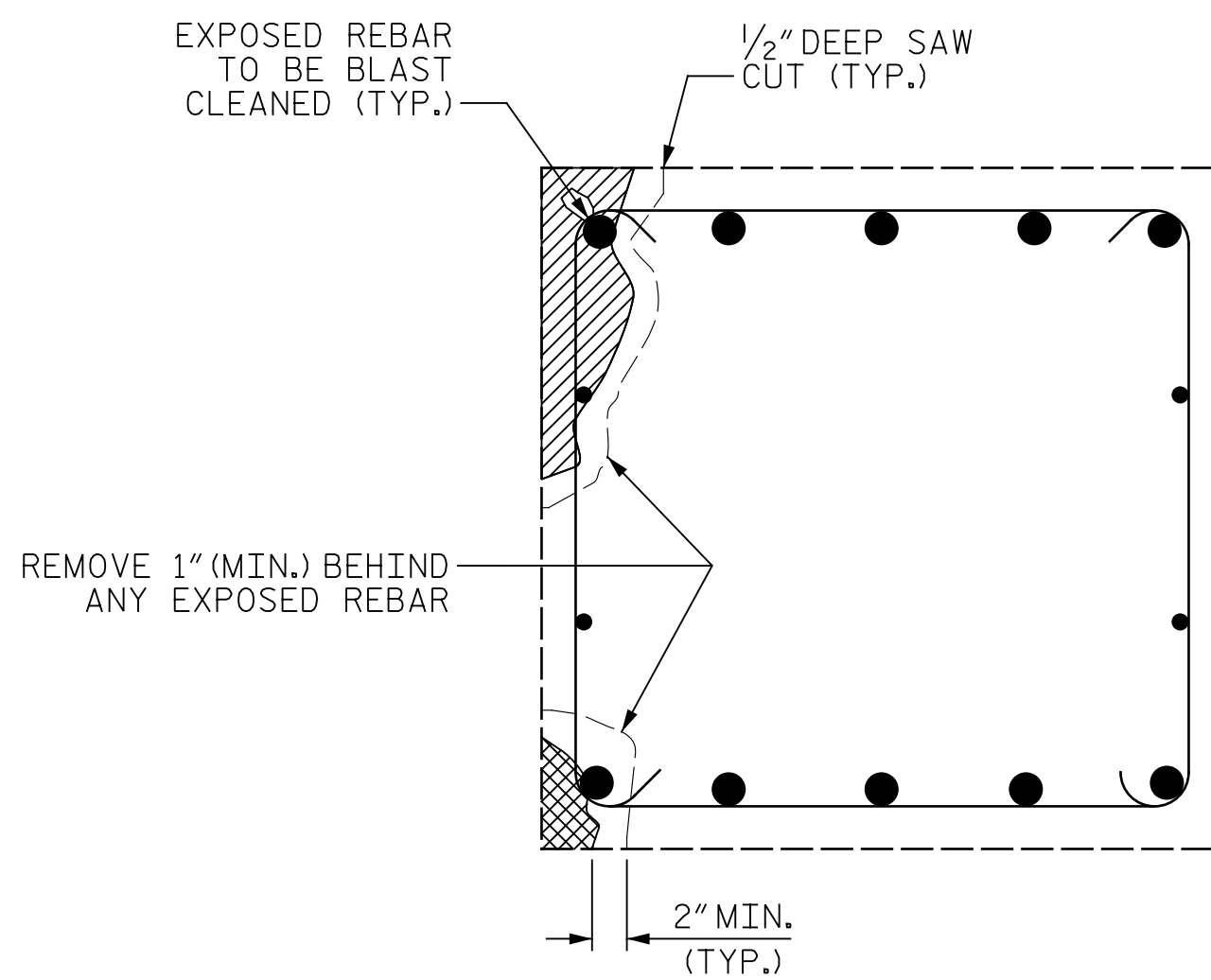

CAP REPAIR

SECTION A-A

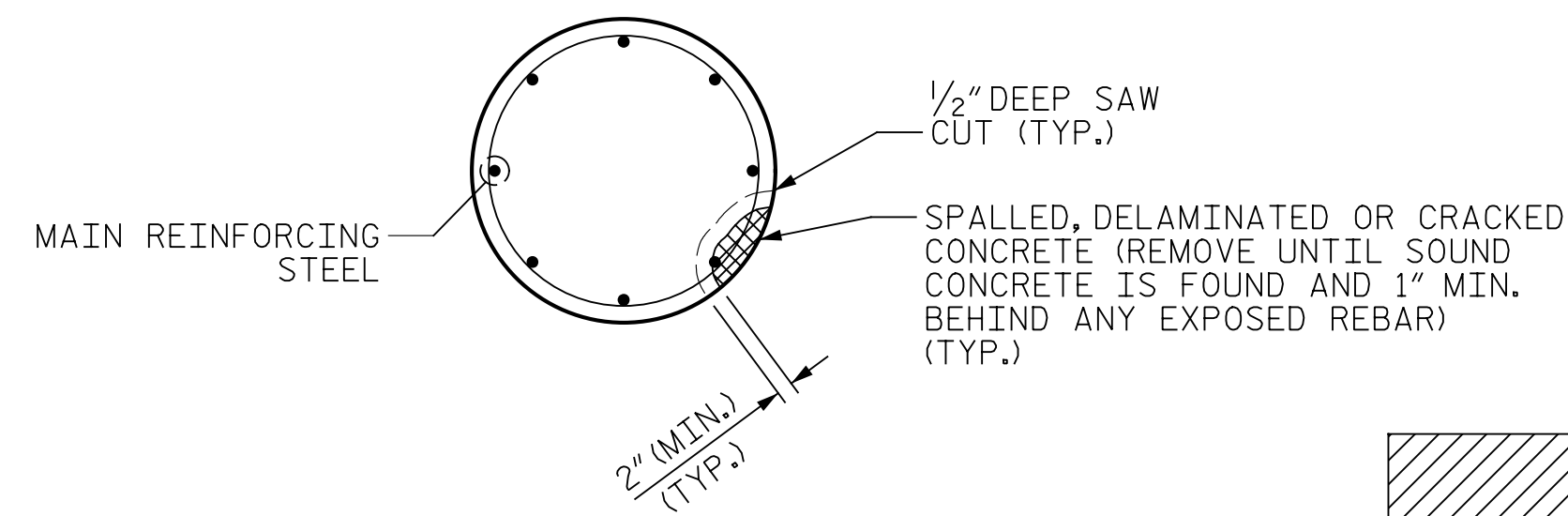

REPAIR KEY

- CONCRETE REPAIR AREA (FORM AND POUR)
- SHOTCRETE REPAIR AREA
- EPOXY RESIN INJECTION (ERI)

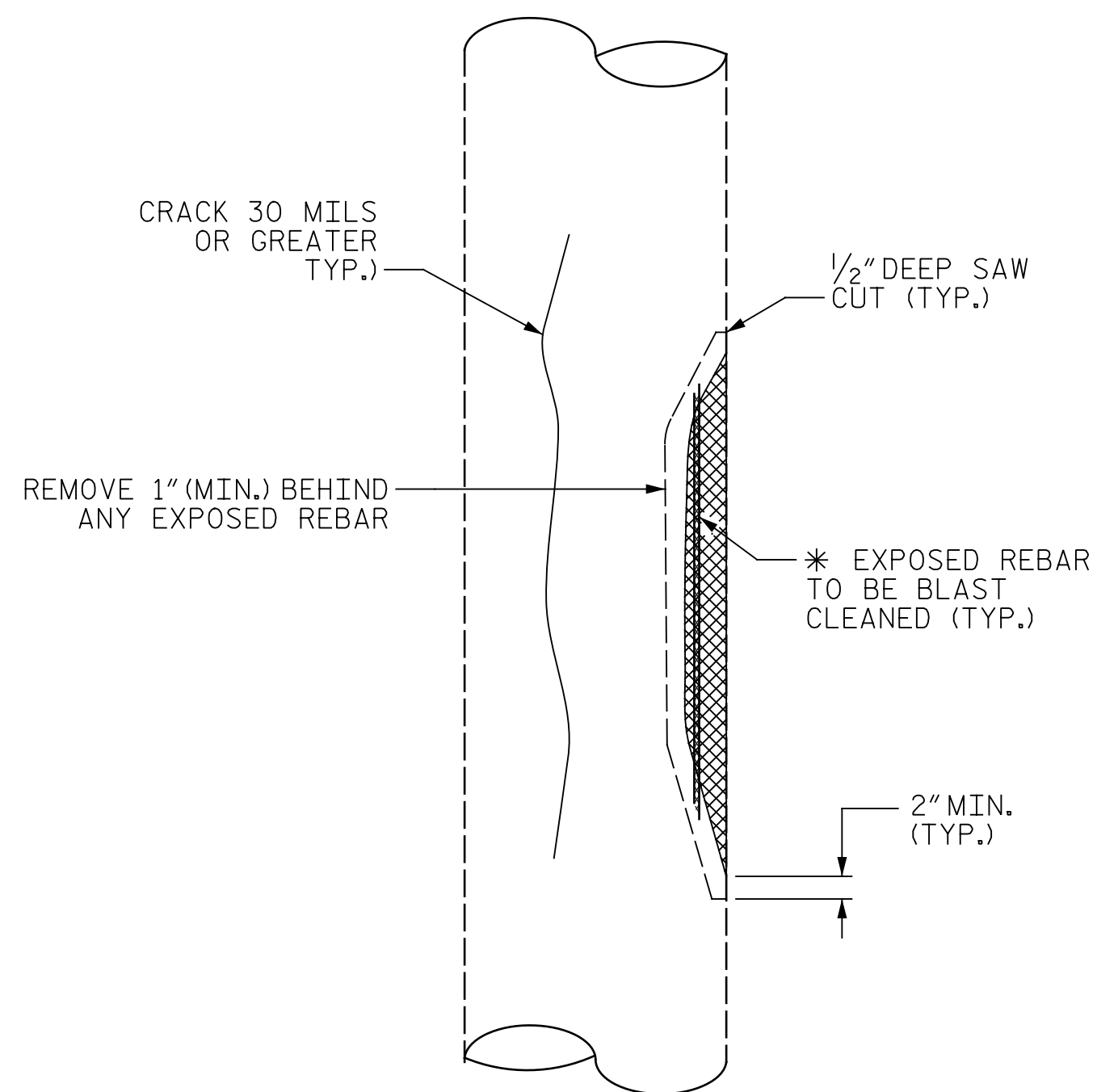

* REPAIR LENGTH SHALL NOT EXCEED 10 FEET.

ELEVATION OF COLUMN

COLUMN REPAIR

SPLICE LENGTH TABLE	
BAR SIZE	MINIMUM SPLICE LENGTH
#4	2'-4"
#5	2'-9"
#6	4'-0"
#7	5'-3"
#8	6'-9"
#9	8'-6"
#10	10'-11"
#11	13'-4"

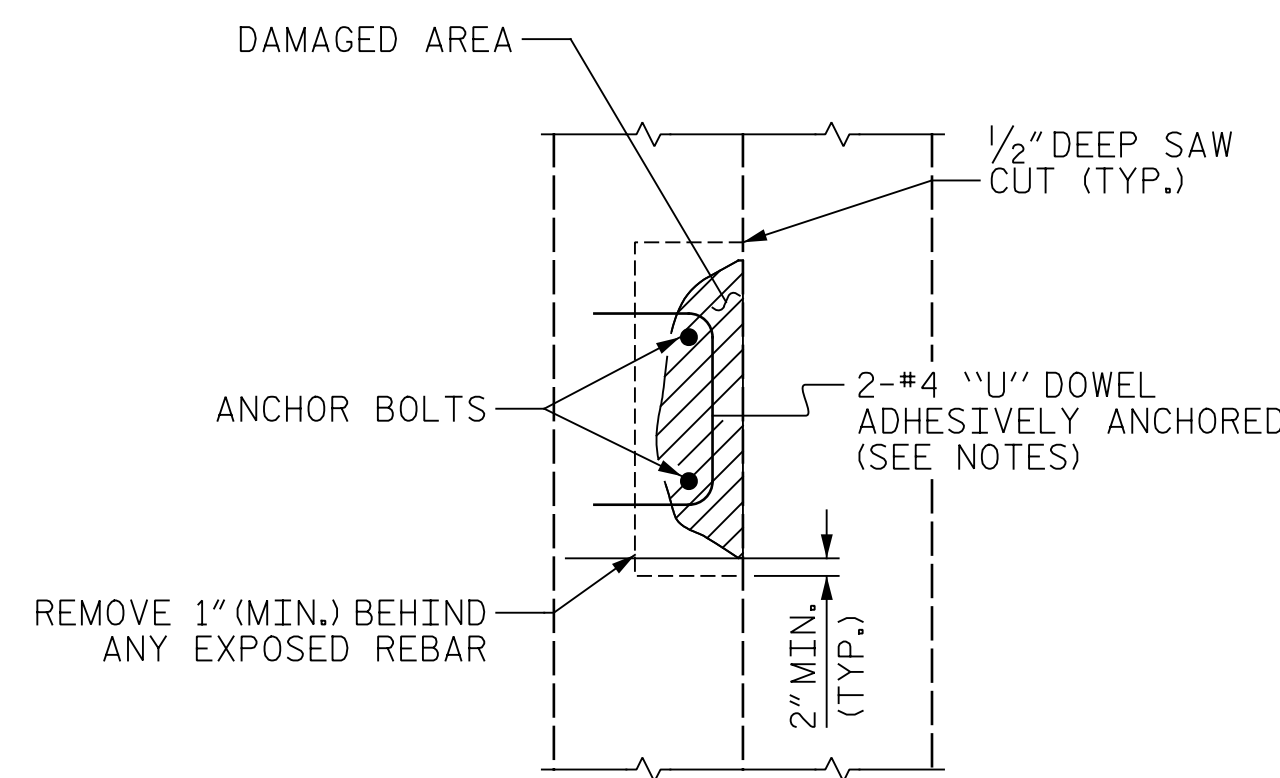

PLAN

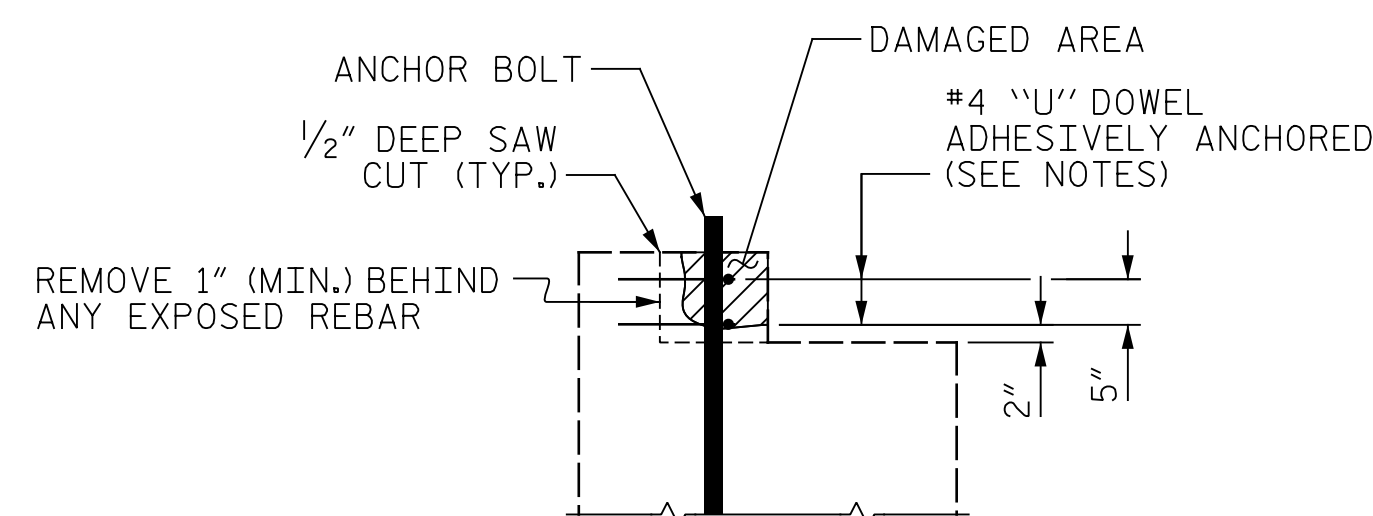

ELEVATION

PEDESTAL WALL REPAIR

NOTES:

TYPICAL BENT CAP REPAIRS ARE SHOWN. REPAIR DETAILS SIMILAR FOR END BENT CAPS AND STRUTS.

THE METHOD USED TO DELINEATE THE AREAS OF UNSOUND CONCRETE TO BE REPAIRED SHALL NOT PERMANENTLY MARK THE CONCRETE, LEAVE ANY RESIDUE AFTER REMOVAL OR REQUIRE HARSH CHEMICALS TO REMOVE.

THE CONTRACTOR SHALL REMOVE THE DETERIORATED CONCRETE IN ACCORDANCE WITH THE GUIDELINES SET IN THESE NOTES, IN THE SPECIAL PROVISIONS AND THE STANDARD SPECIFICATIONS.

REMOVE UNSOUND CONCRETE TO THE EXTENT NECESSARY, MINIMUM OF 1" BEHIND REBAR AND MINIMUM OF 2" CLEARANCE TO SAWCUT.

NO MORE THAN ONE-THIRD OF THE CAP OR COLUMN CROSS SECTIONAL AREA SHALL BE REMOVED AT ONE TIME. SHOULD IT BECOME NECESSARY TO REMOVE MORE THAN 30% OF A CAP OR COLUMN CROSS SECTIONAL AREA, NOTIFY THE ENGINEER PRIOR TO PROCEEDING.

SIMULTANEOUS REMOVAL OF UNSOUND CONCRETE MAY BE PERMITTED ON MORE THAN ONE FACE OF A CAP AND/OR COLUMN, IF THE AREAS OF REMOVAL ARE NOT ADJACENT TO OR DIRECTLY OPPOSITE ONE ANOTHER. IF REMOVAL EXTENDS MORE THAN 1/2" BEHIND THE MAIN REINFORCING BARS, NOTIFY THE ENGINEER PRIOR TO PROCEEDING.

REINFORCING STEEL WHICH IS DETERMINED BY THE ENGINEER TO BE REPLACED, SHALL BE REMOVED TO A POINT WHERE IT IS SOUND. THE PATCH SHALL EXTEND A SUFFICIENT DISTANCE BEYOND THIS POINT TO DEVELOP A SPLICE LENGTH SPECIFIED IN THE TABLE ON THIS SHEET.

THE #4 "U" DOWELS ARE REQUIRED ONLY AROUND THE ANCHOR BOLTS. THE EXISTING REINFORCING STEEL IN THE PEDESTAL WALL SHALL BE CLEANED, STRAIGHTENED AND REMAIN IN PLACE.

FOR ADHESIVELY ANCHORED ANCHOR BOLTS OR DOWELS, SEE STANDARD SPECIFICATIONS.

COAT ALL REPAIR SURFACE AREAS ON THE TOP OF CAPS, INCLUDING CHAMFERS, WITH EPOXY PROTECTIVE COATING, OVERLAPPING THE REPAIR AREA BY A MINIMUM OF 3" ON ALL POSSIBLE SIDES.

FOR SHOTCRETE REPAIRS, SEE SPECIAL PROVISIONS.

FOR CONCRETE REPAIRS, SEE SPECIAL PROVISIONS.

FOR EPOXY PROTECTIVE COATING, SEE SPECIAL PROVISIONS.

FOR EPOXY RESIN INJECTION (ERI), SEE SPECIAL PROVISIONS.

PROJECT NO. 15BPR.44
CUMBERLAND COUNTY
 BRIDGE NO. 250053



DocuSigned by:
 Eric B. Nelson 12/3/2021

STATE OF NORTH CAROLINA
 DEPARTMENT OF TRANSPORTATION
 RALEIGH

TYPICAL
 CAP AND COLUMN
 REPAIR DETAILS

DRAWN BY : J. MYA DATE : 01/2021
 CHECKED BY : J. YANACCONO DATE : 01/2021

PLANS PREPARED BY:
 2610 Wycliff Road
 Suite 102
 Raleigh NC 27607-3073
 (919) 420-7660
 Excellence Delivered As Promised [NC Lic. No. F-0270]

DOCUMENT NOT CONSIDERED
 FINAL UNLESS ALL
 SIGNATURES COMPLETED

REVISIONS						SHEET NO.
NO.	BY:	DATE:	NO.	BY:	DATE:	S-17
1			3			TOTAL SHEETS
2			4			19