

Concrete Shaft Elevation

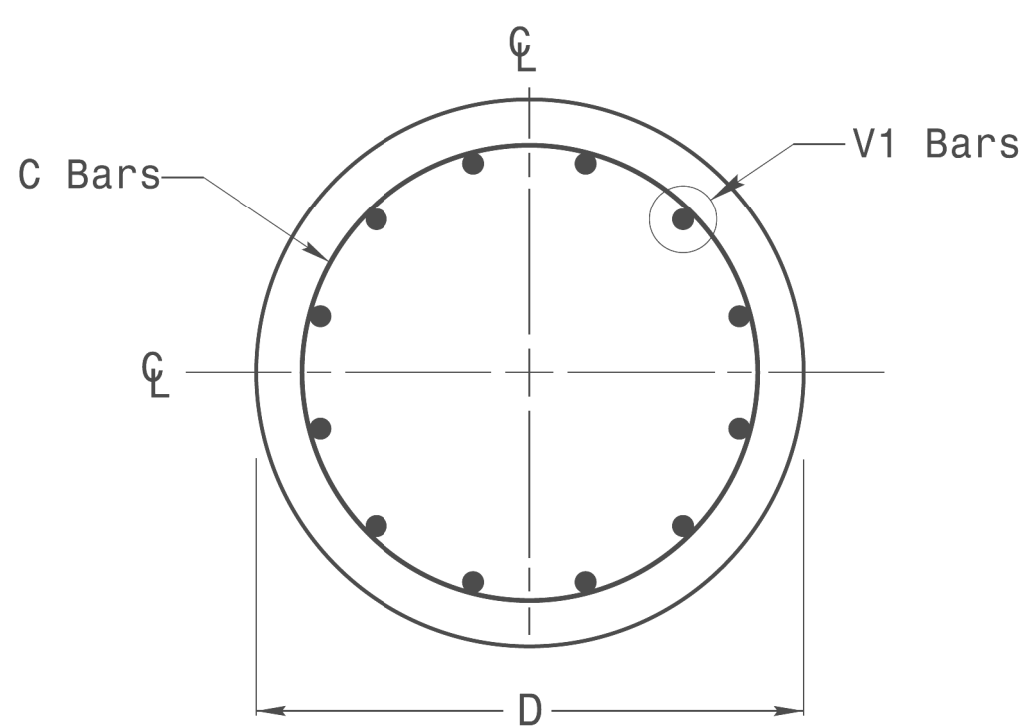

Section A-A

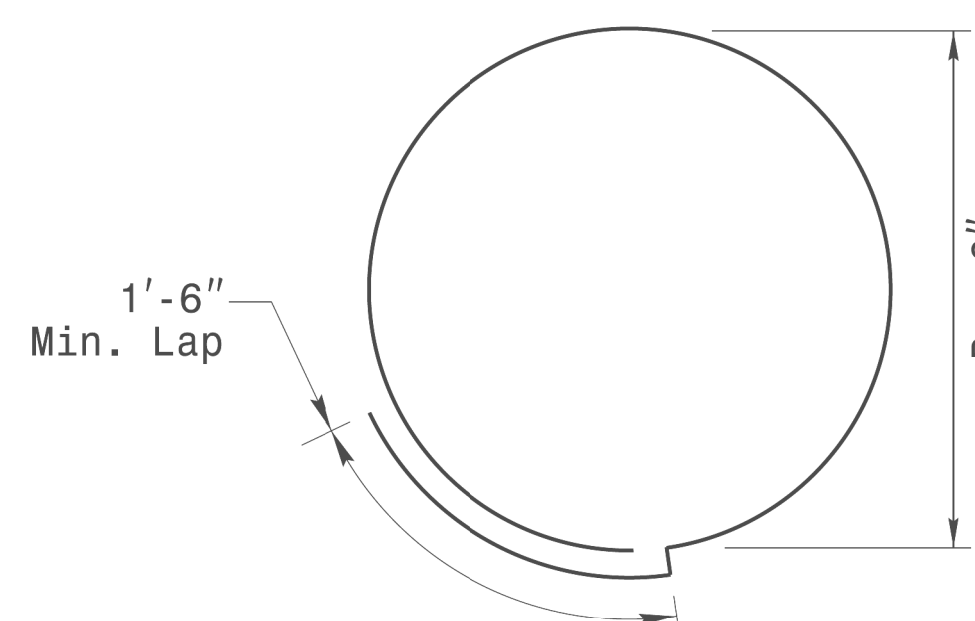

Typical "C" Bar Detail

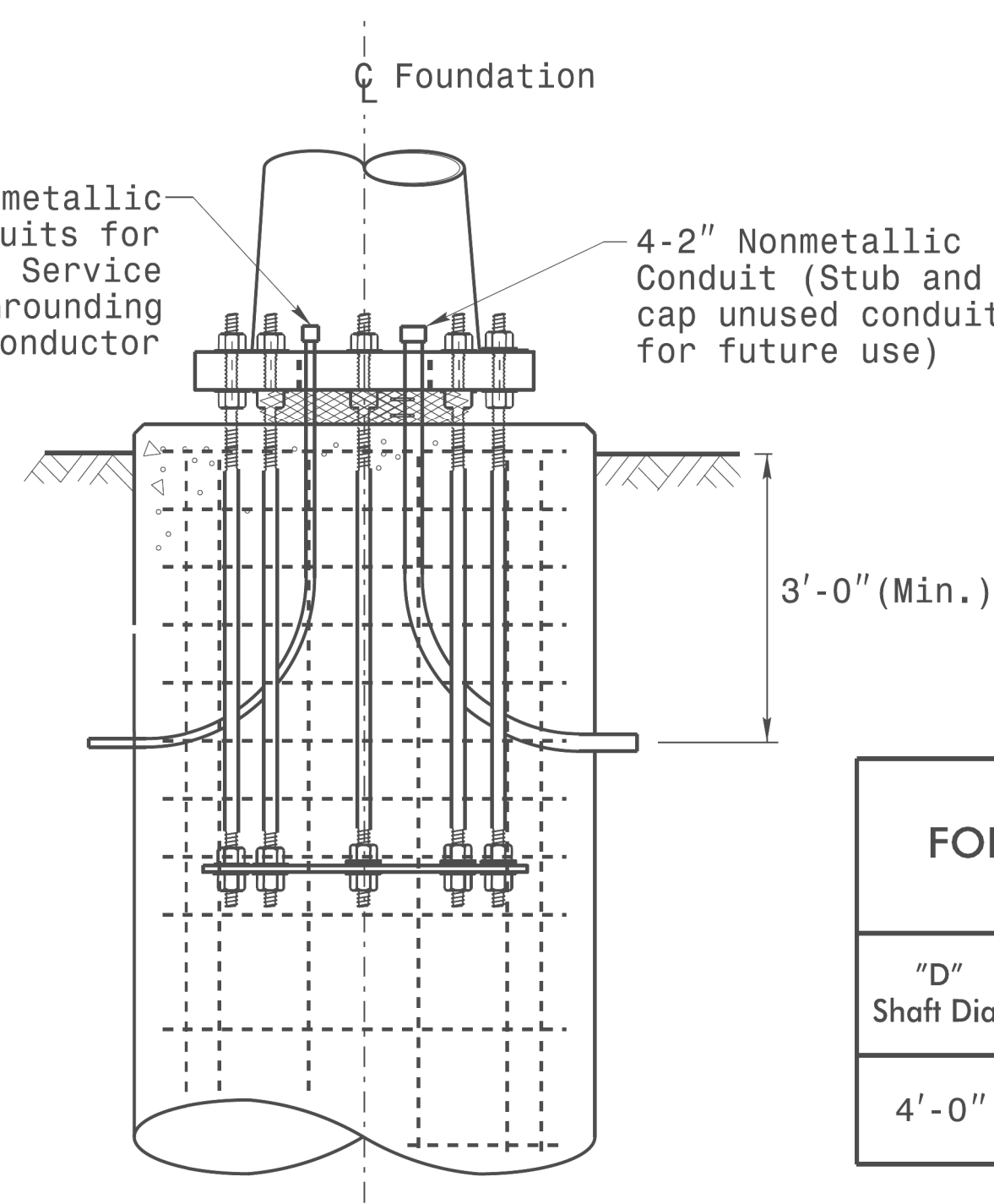

Typical Foundation Conduit Details

REINFORCING STEEL TABLE FOR STANDARD DRILL PIER SHAFT (4'-0" DIAMETER)

"D" Shaft Dia.	Conc. Volume (cu. yds.)	Bar Name	MIN.	Size	Type	Length
4'-0"	.465 x L	V1	-	#8	STR.	**
		C	*	#4	CIR.	12'-6"

* See Note No. 2
 ** See Note No. 3

General Notes:

- If actual subsurface conditions differ significantly from boring data contact the Engineer before excavating or placing concrete.
- Circular tie reinforcing rings may be vertically adjusted by +/-3" at a depth between 2'-0" and 3'-0" to facilitate the installation of electrical conduit entering in the cage.
- For standard foundations, see sheet Sig. M8 for details. Vertical reinforcing bars (V1) may be horizontally adjusted by +/-3" to facilitate the installation of electrical conduit entering into the cage.
- Provide 2" to 5" foundation projection above ground level depending on the ground slope.
- Unless otherwise shown, foundation designs are based on non-sloping level ground surfaces with slope ratios of 8:1 (H:V) or flatter. If actual ground line slopes are steeper contact the Engineer before excavating or placing concrete.
- Construct foundations in accordance with NCDOT Standard Provisions SP09 R005- Foundations and Anchor Rod Assemblies for Metal Poles. All applicable 2018 NCDOT Standard Specifications are referenced in this provision. Refer to the NCDOT Resources/Specifications page located on the Connect NCDOT website.
<https://connect.ncdot.gov/resources/Specifications and Special Provisions.aspx>
- Use air entrained AA concrete mix with a compression strength of f'c=4500 psi.(min.) after 28 days.
- Use ASTM A615 grade 60 deformed bars for all reinforcing steel. Maintain at least 3" cover on all reinforcement.
- Locate the Identification Tag on the top of the base plate, directly above the conduit's entry point.
- Provide two layers of galvanized welded 23 gauge (0.25) 6" wide 4 mesh wire around pipes under the base plate and secure it with ties if necessary.
- Preferred location for the I.D. Tag is as shown in Detail-A; directly above the conduit entering the foundation.

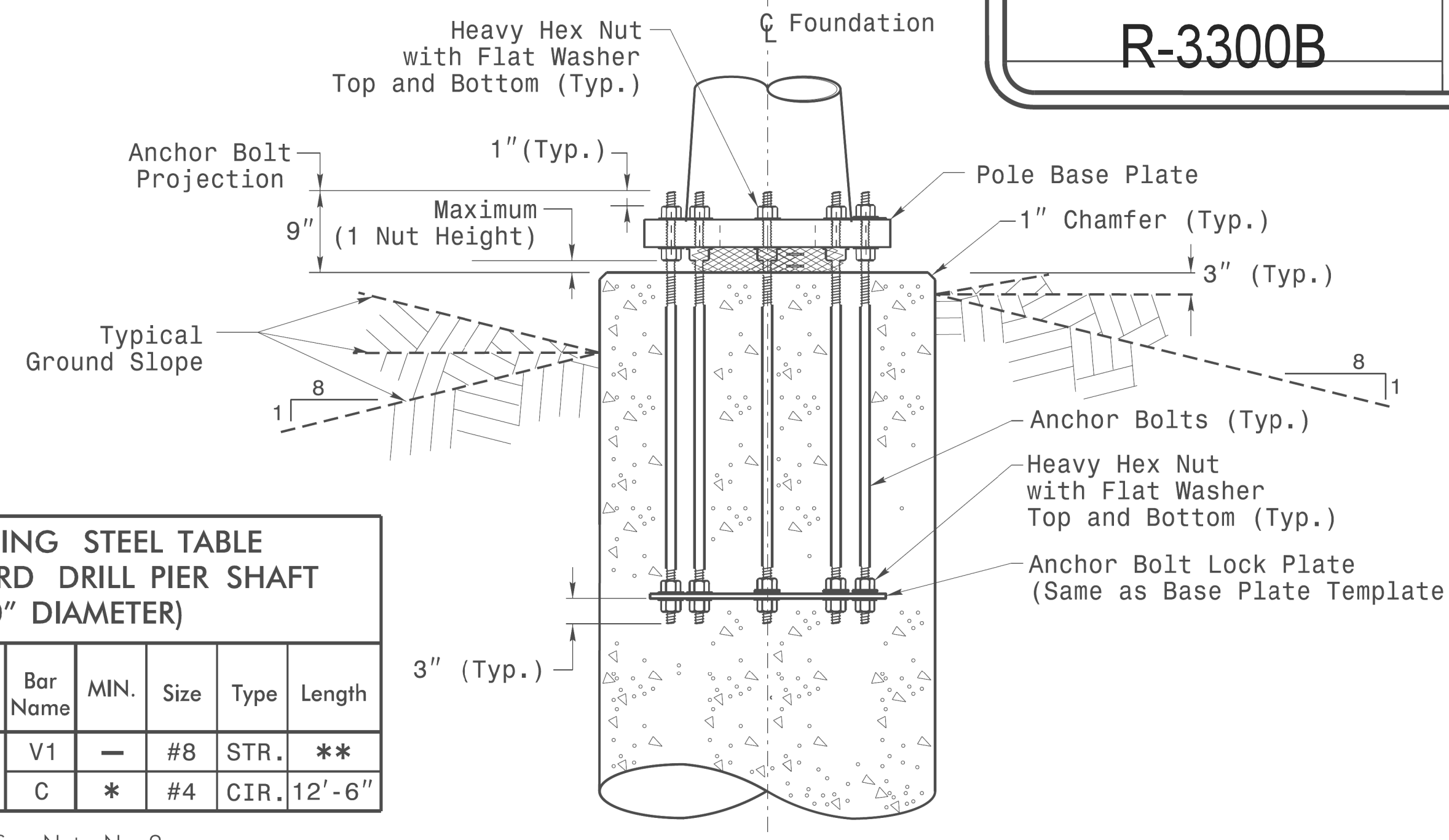

Typical Foundation Anchor Bolt Details

(Reinforcing Cage Not Shown for Clarity)

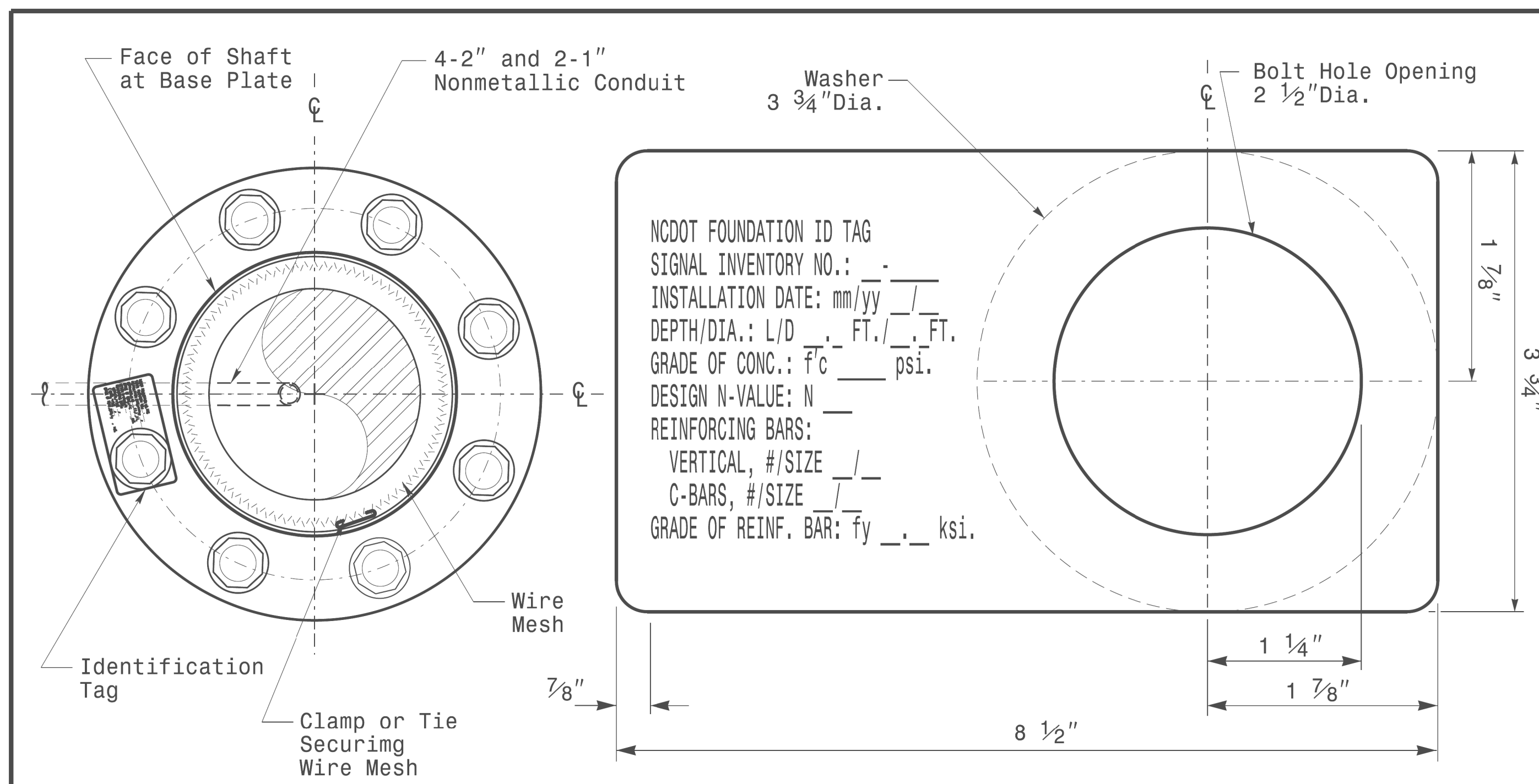

Concrete Foundation Identification Tag Details

Detail-A

D = Diameter
 L = Length/Depth
 mm = Month
 yy = Year

Prepared In the Offices of:

Construction Details For Foundations

PLAN DATE: OCTOBER 2018 DESIGNED BY: C.B. COGDILL
 PREPARED BY: N. BITTING REVIEWED BY: D.C. SARKAR

750 N. Greenfield Pkwy, Garner, NC 27529

SCALE: 0 NA NONE

REVISIONS:

REV. NO.	COMMENTS	INIT.	DATE
1	Revised Foundation Tag Details	N.B.	5/11/2015

SEAL: NORTH CAROLINA PROFESSIONAL ENGINEER SEAL 028094 D.C. SARKAR

DocuSigned by: Debesh C. Sarkar ADDRESS SIGNATURE DATE: 10/11/2017

Construction Details - Foundations