

SURFACE PREPARATION
(SCARIFICATION AND SHOTBLASTING)

SURFACE PREPARATION
(SCARIFICATION AND SHOTBLASTING)

SURFACE PREPARATION
(SCARIFICATION AND SHOTBLASTING)

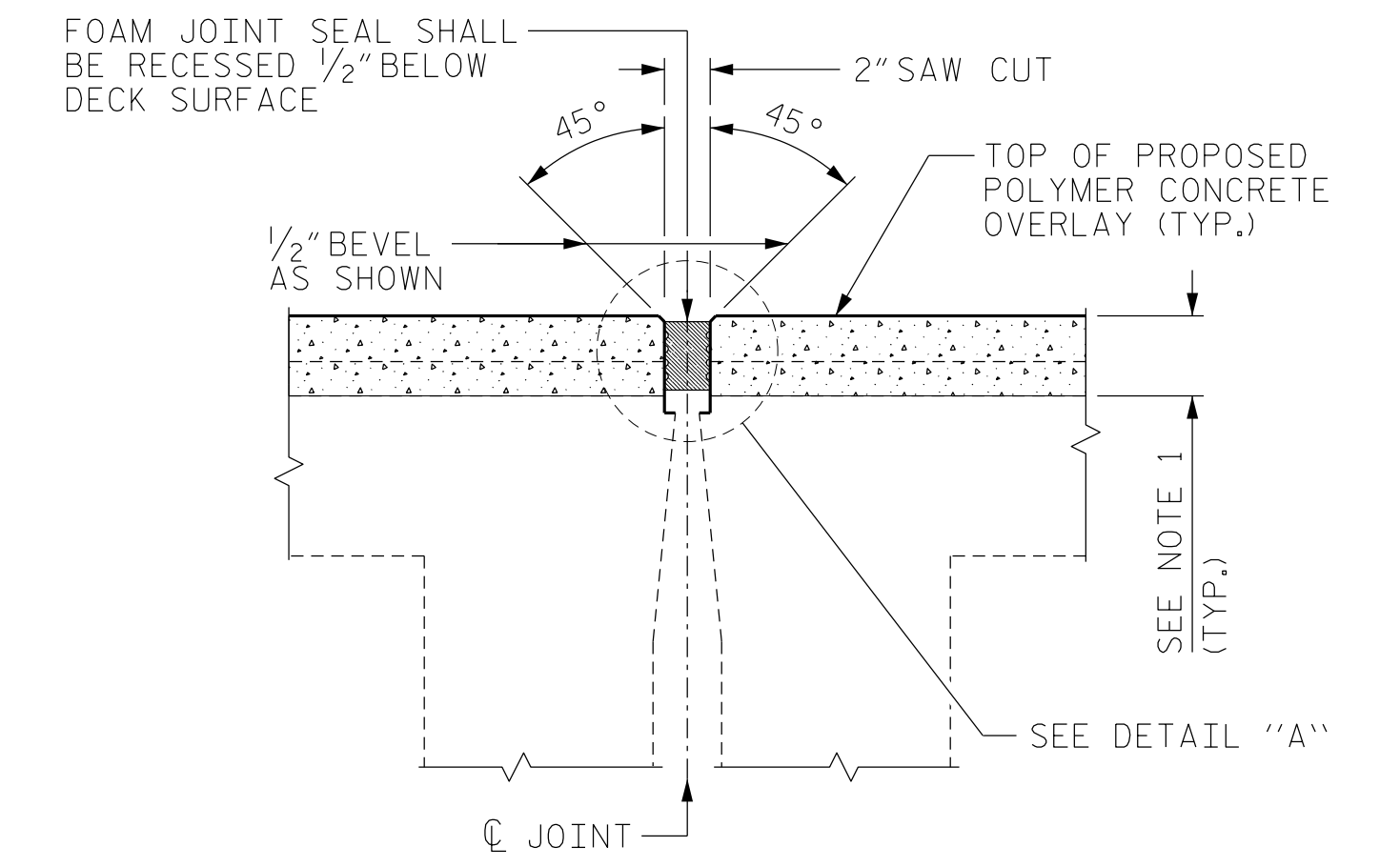
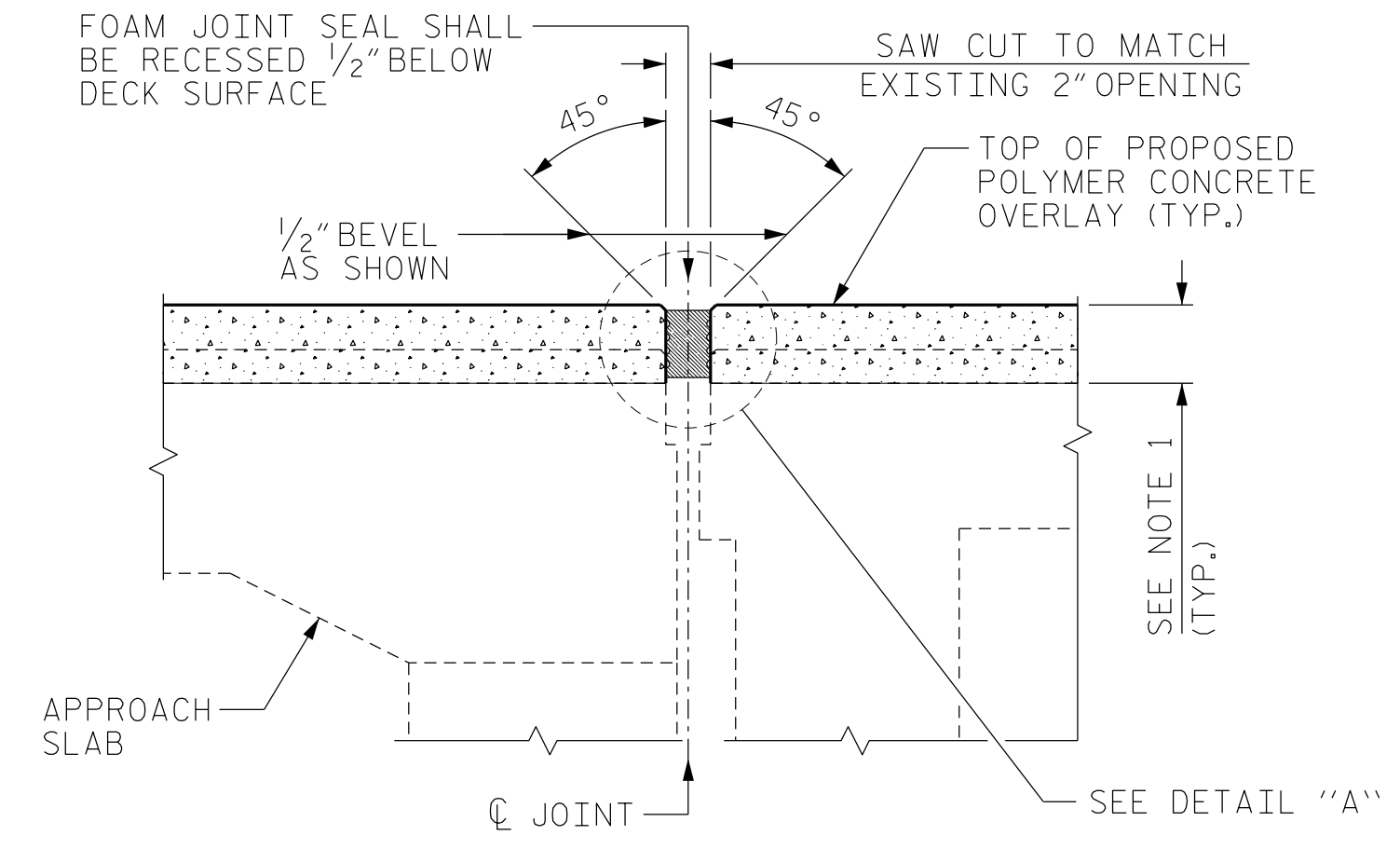
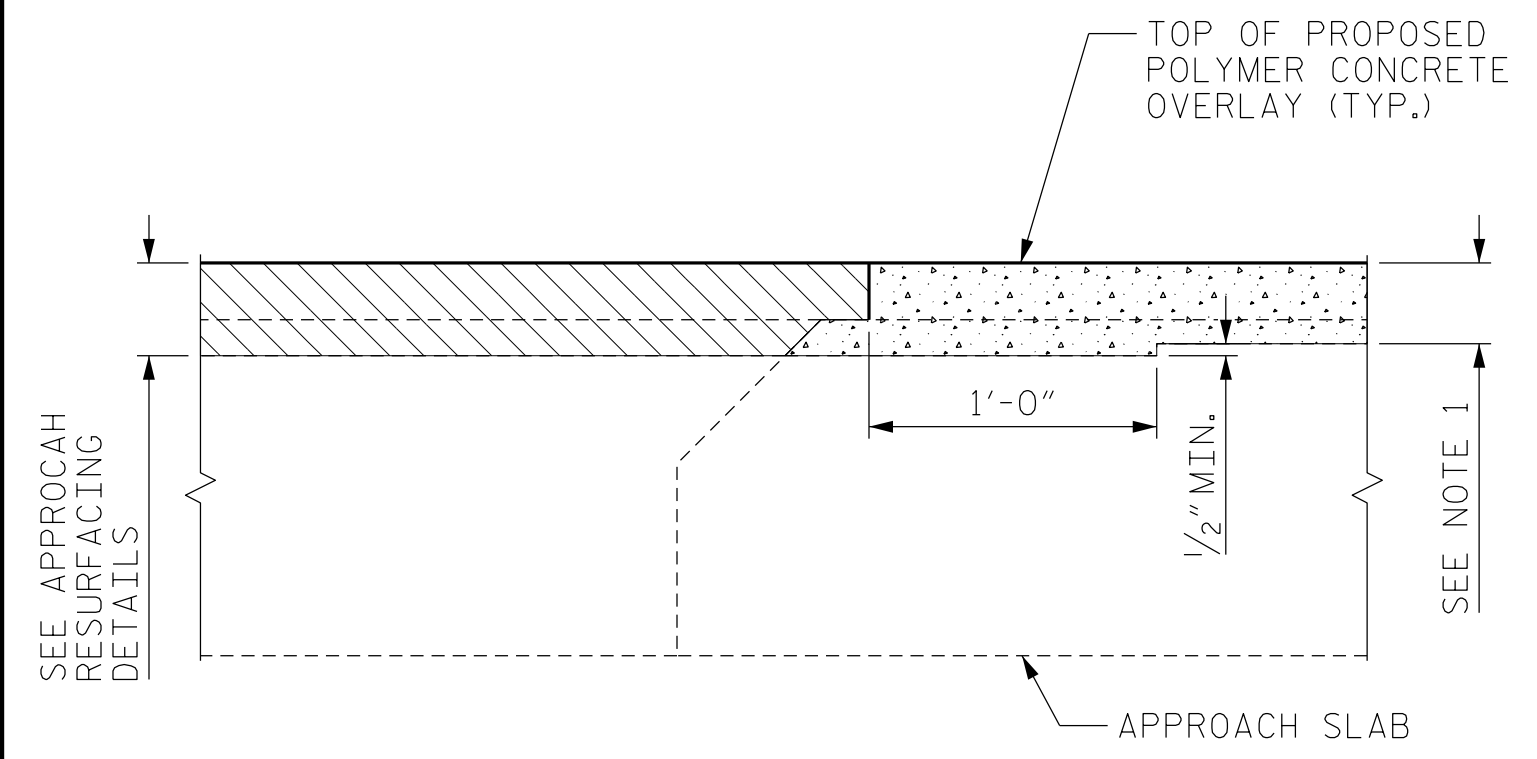

PROPOSED JOINT
APPROACH SLABS

PROPOSED JOINT
(FOAM JOINT SEAL)

PROPOSED JOINT
(FOAM JOINT SEAL)

END BENTS

INTERMEDIATE BENTS
(BENTS: 1 THRU 14, AND 19 THRU 72)

TYPICAL JOINT DETAILS

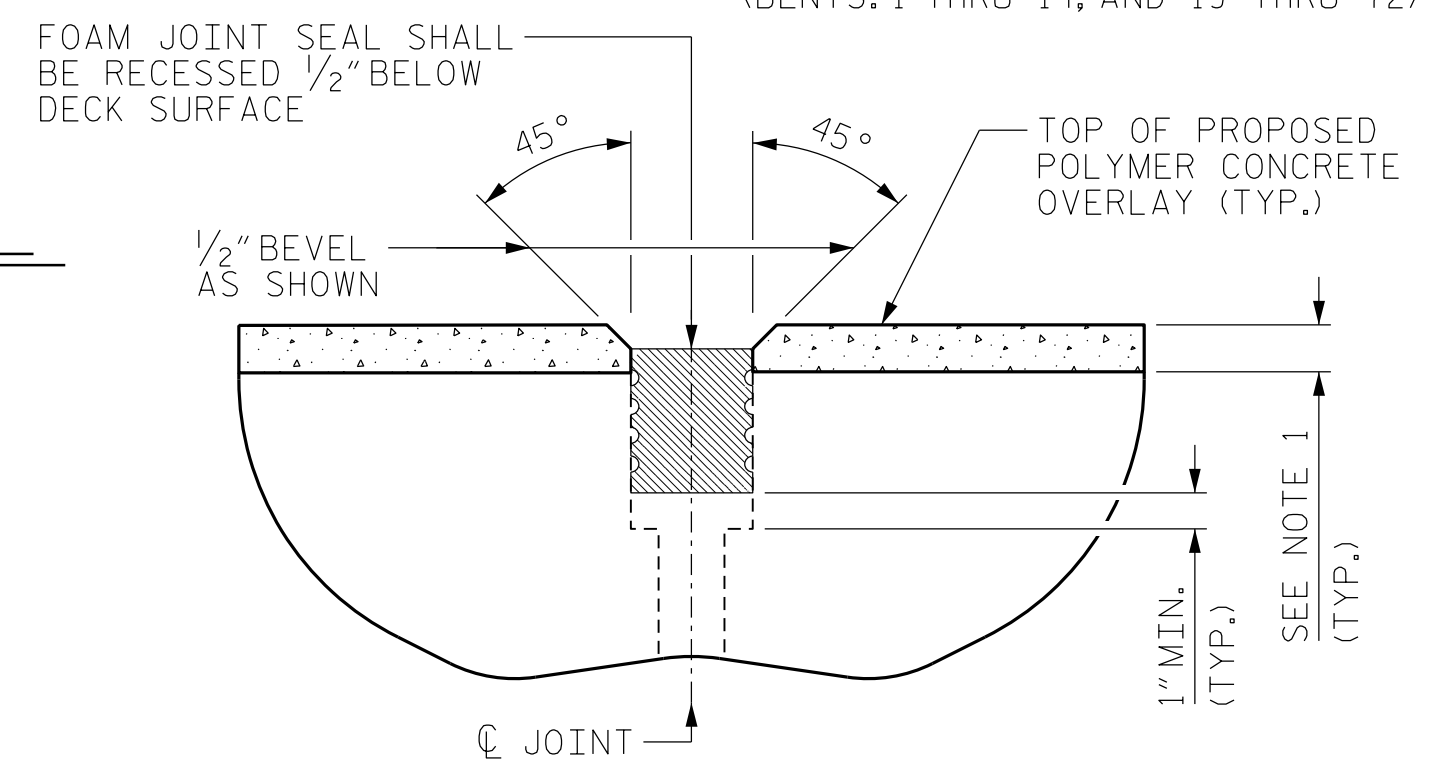

DETAIL "A"
(PROPOSED JOINT SEAL)

NOTES:

THE EXISTING PROFILE GRADE HAS BEEN MODIFIED FOR RIDEABILITY CORRECTION. AS SUCH THE PC OVERLAY THICKNESS VARIES ALONG THE LENGTH OF THE BRIDGE. FOR PC OVERLAY THICKNESS, SEE "DECK SURFACE REPAIR" SHEETS.

IF ENCOUNTERED, RETAIN ALL EXISTING REINFORCING STEEL. CLEAN AND REPAIR IF NECESSARY.

THE CONTRACTOR SHALL FIELD VERIFY THE EXISTING JOINT OPENING PRIOR TO ORDERING JOINT SEAL MATERIAL. IF THE ACTUAL OPENING VARIES FROM THE OPENING INDICATED IN THE DETAIL BY MORE THAN 1/4", NOTIFY THE ENGINEER. REVISION OF THE JOINT SEAL SIZE MIGHT BE NECESSARY.

THE MANUFACTURER IS TO PROVIDE THE NOMINAL UNCOMPRESSED SEAL WIDTH OF THE FOAM JOINT SEAL FOR THE SIZE OF THE OPENING ON THE PLANS AND ACCOMMODATE THE MINIMUM EXPANSION SHOWN ON THE PLANS.

FOAM JOINTS SHALL BE INSTALLED AS PER THE MANUFACTURER'S RECOMMENDATIONS.

THE CONTRACTOR SHALL TAKE CARE DURING JOINT REHAB OPERATIONS NOT TO DROP ANY MATERIAL THAT FALLS BELOW THE BRIDGE, WITHOUT PROTECTIVE DEVICES BELOW TO CATCH THE MATERIAL. ANY MATERIAL THAT FALLS BELOW THE BRIDGE SHALL BE CONTAINED, REMOVED AND DISPOSED OF BY THE CONTRACTOR AT NO EXTRA COST TO THE DEPARTMENT. IF THE ENGINEER DETERMINES THAT THE PROTECTIVE DEVICES ARE NOT ADEQUATE OR NOT BEING EMPLOYED, THE WORK SHALL BE SUSPENDED UNTIL ADEQUATE PROTECTION IS PROVIDED.

THE CONTRACTOR WILL NOT BE PERMITTED TO FORM THE JOINTS IN LIEU OF SAWING THE JOINT.

THE INSTALLED FOAM JOINT SHALL BE WATER TIGHT.

QUANTITIES SHOWN IN THE ELASTOMERIC CONCRETE FOR PRESERVATION TABLE BASED ON THE MINIMUM JOINT DEMOLITION SHOWN.

FOR EXCAVATION BELOW THE BOTTOM OF THE PLANNED JOINT DECK DEMOLITION, CONCRETE FOR DECK REPAIRS SHALL BE PLACED IN THE EXCAVATED AREA TO THE ELEVATION AT BOTTOM OF THE PROPOSED ELASTOMERIC CONCRETE FOR PRESERVATION HEADERS SHOWN.

FOR BRIDGE JOINT DEMOLITION, SEE SPECIAL PROVISIONS.

FOR FOAM JOINT SEALS FOR PRESERVATION, SEE SPECIAL PROVISIONS.

FOR CONCRETE FOR DECK REPAIR, SEE SPECIAL PROVISIONS.

IF THE EMBEDDED PORTION OF THE EXISTING PLASTIC WATERSTOP IS EXPOSED DURING REMOVAL OF UNSOUND CONCRETE, OR IF UNSOUND CONCRETE IS REMOVED WITHIN 2" OF THE WATERSTOP, THE ENTIRE CONCRETE DEPTH TO THE WATERSTOPS SHALL BE REMOVED. IF SUCH EXCAVATION EXTENDS MORE THAN 2" BELOW THE BOTTOM OF THE PLANNED ELASTOMERIC CONCRETE HEADER, AS SHOWN, APPROVED REPAIR CONCRETE SHALL BE PLACED IN THE EXCAVATED AREA TO THE ELEVATION AT THE BOTTOM OF THE ELASTOMERIC CONCRETE.

DEMOLISH BRIDGE JOINT AREA SUCH THAT THE BOTTOM OF THE EXCAVATION SHALL BE REASONABLY FLAT AND LEVEL AND TO THE NECESSARY DEPTH, SUCH THAT ELASTOMERIC CONCRETE SHALL BE FOUNDED ON CONCRETE OR REPAIR CONCRETE SUBSTRATE.

PROJECT NO. 15BPR.46
DARE COUNTY
 BRIDGE NO. 270012

SHEET 1 OF 2

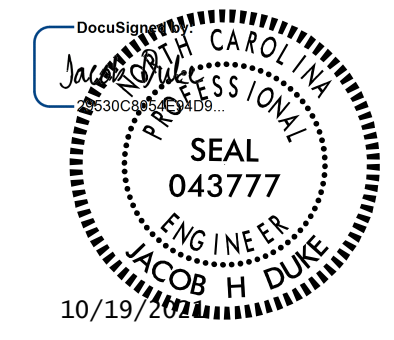

STATE OF NORTH CAROLINA
 DEPARTMENT OF TRANSPORTATION
 RALEIGH

JOINT DETAILS

DRAWN BY DIEGO A. AGUIRRE DATE : 9/30/2020
 CHECKED BY : JACOB H. DUKE DATE : 10/1/2020
 DESIGN ENGINEER OF RECORD: JACOB H. DUKE DATE : 10/1/2020

10/19/2021
 15BPR.46.SMU.JT01.270012.dgn
 jduke

DOCUMENT NOT CONSIDERED
 FINAL UNLESS ALL
 SIGNATURES COMPLETED

REVISIONS						SHEET NO.
NO.	BY:	DATE:	NO.	BY:	DATE:	S-20
1			3			TOTAL SHEETS
2			4			137