

NOTES:

STIRRUPS IN CAP MAY BE SHIFTED AS NECESSARY TO CLEAR #4 VI BARS.

THE TOP PART OF THE END BENT CAP AND WINGS, EXCEPT THE BEARING AREA, SHALL BE RAKED TO A DEPTH OF 1/4".

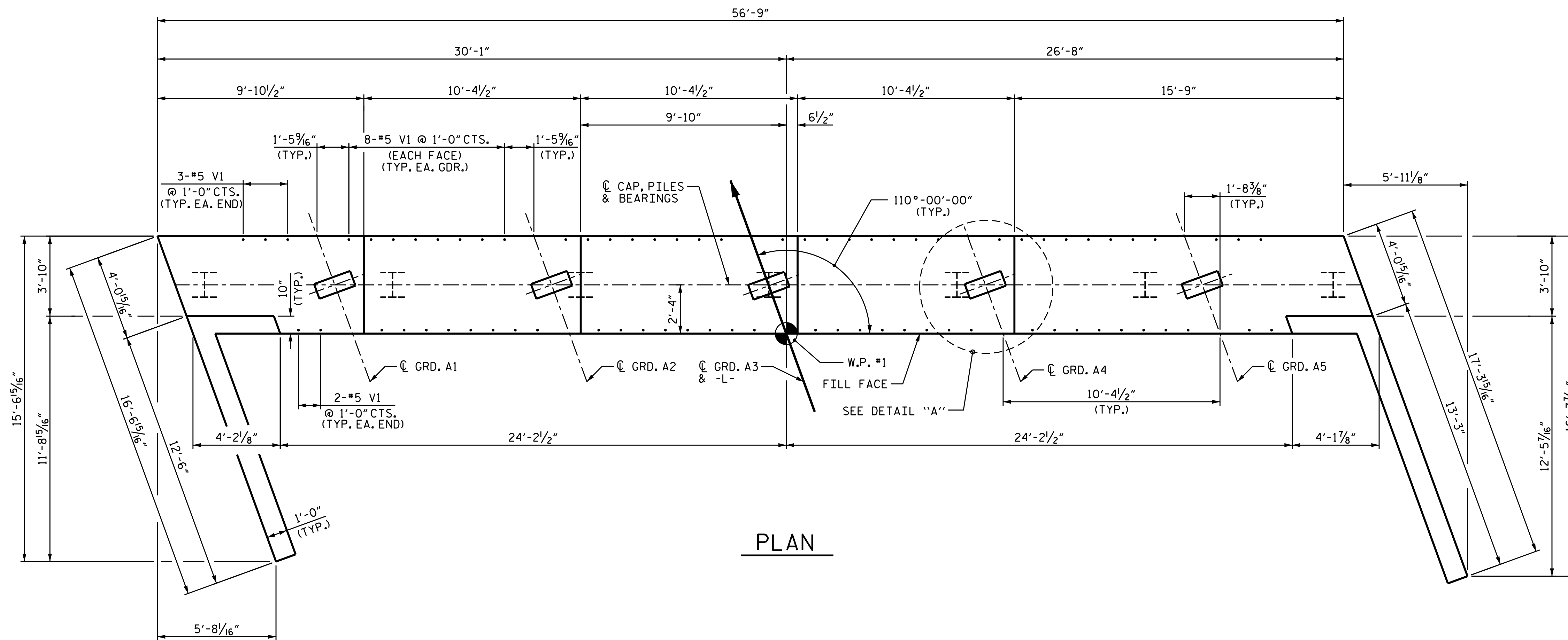

PLAN

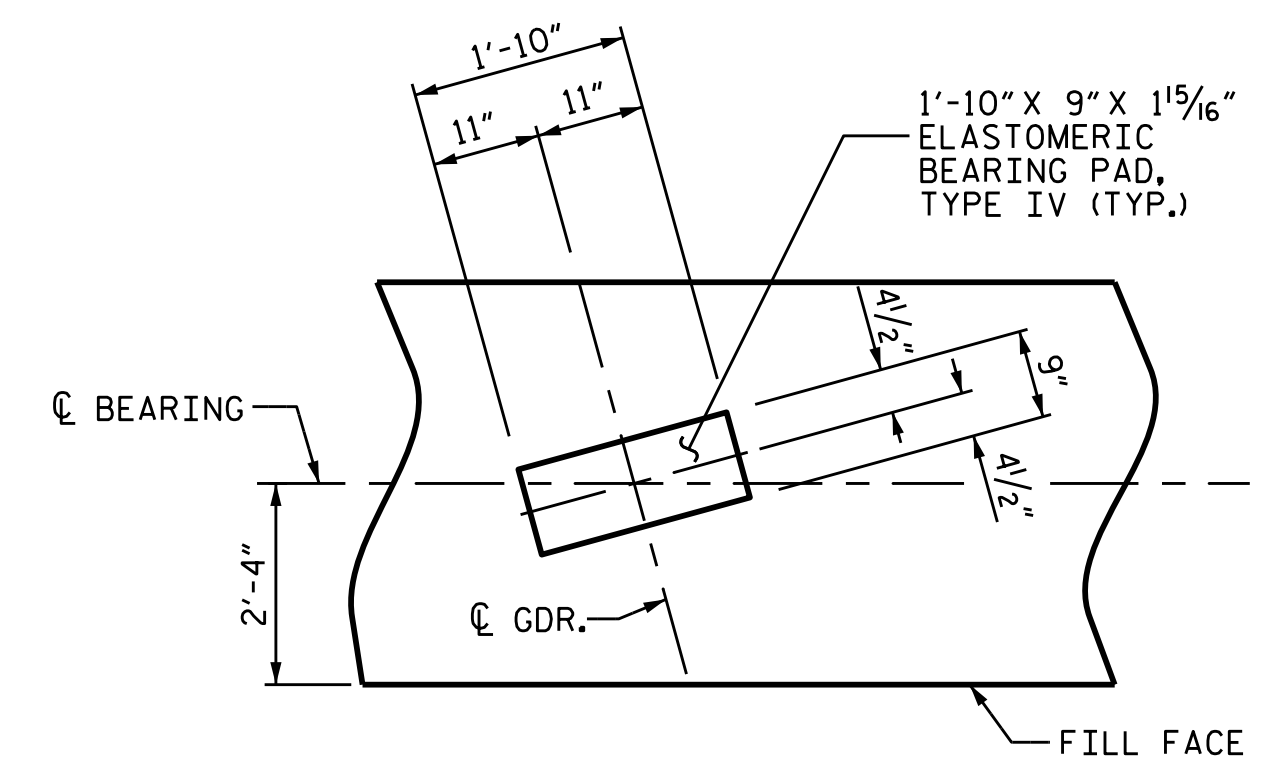

DETAIL "A"

(TYP. EA. GDR.)

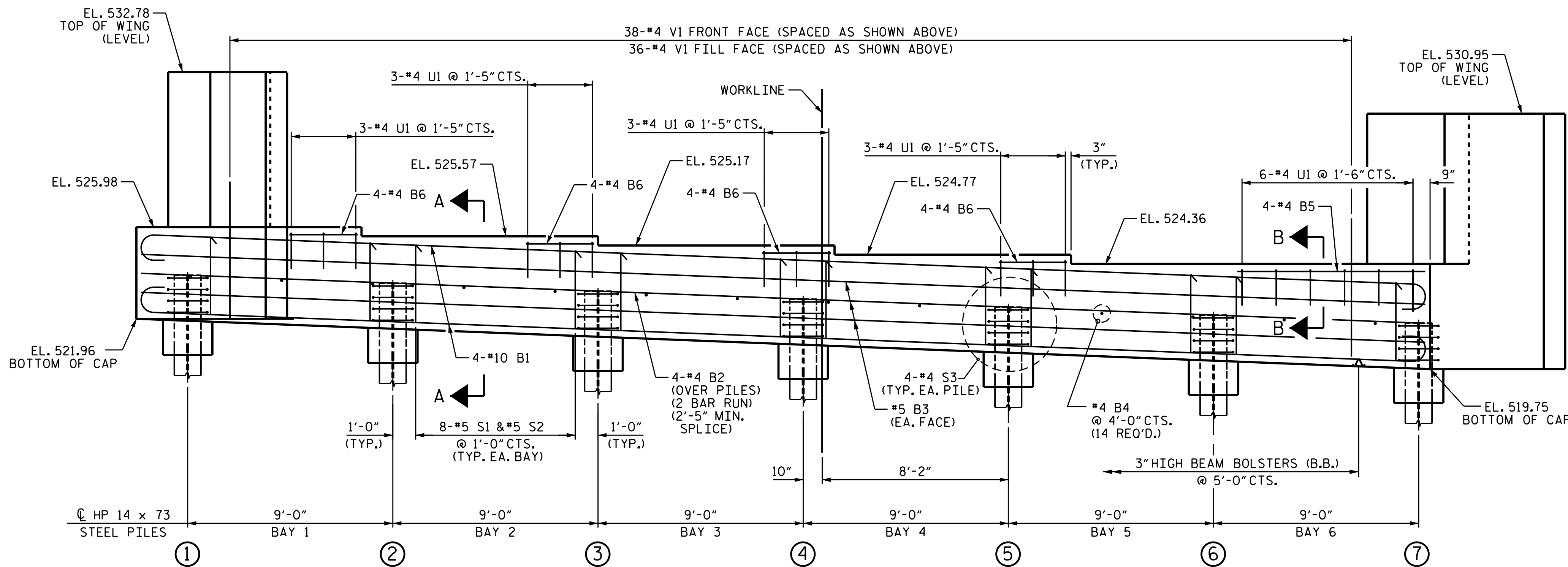

ELEVATION

TOP OF PILE ELEVATIONS	
①	523.925
②	523.575
③	523.225
④	522.874
⑤	522.524
⑥	522.174
⑦	521.824

PROJECT NO. B-5813
CABARRUS COUNTY
 STATION: 21+85.00 -L-

SHEET 1 OF 3

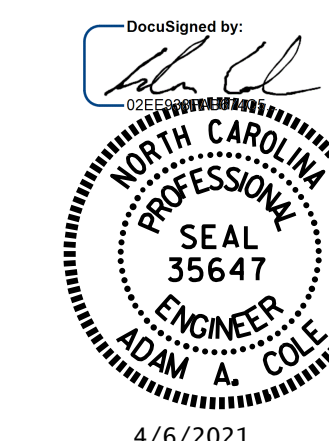

4/6/2021

STATE OF NORTH CAROLINA
 DEPARTMENT OF TRANSPORTATION
 RALEIGH
 SUBSTRUCTURE
INTEGRAL END BENT 1

DRAWN BY : M. G. SHAIKH DATE : 09/2019
 CHECKED BY : H. LOCKLEAR DATE : 09/2019
 DESIGN ENGINEER OF RECORD: H. LOCKLEAR DATE : 08/2019

DOCUMENT NOT CONSIDERED
 FINAL UNLESS ALL
 SIGNATURES COMPLETED

REVISIONS						SHEET NO.
NO.	BY:	DATE:	NO.	BY:	DATE:	S-19
1			3			TOTAL SHEETS
2			4			29