

TIP NO. B-5624	SHEET NO. PMP-2
APPROVED: <i>Adam M. Conrad, P.E., PMP</i> 6/7/2021	
DATE: 6/7/2021	
SEAL 	
DOCUMENT NOT CONSIDERED FINAL UNLESS ALL SIGNATURES COMPLETED	
CDM Smith CDM Smith Inc. 5400 Glenwood Avenue Suite 400 Raleigh, NC 27612-3228 NC COA No. F-1255	

PAVEMENT MARKING SCHEDULE	
SYMBOL	DESCRIPTION
THERMO (4", 90 MILS)	
T1	WHITE EDGELINE
T13	YELLOW DOUBLE CENTER
POLYUREA (4", 20 MILS)	
V1	WHITE EDGELINE
V13	YELLOW DOUBLE CENTER
PERMANENT RAISED PAVEMENT MARKERS	
MA	YELLOW & YELLOW
SNOWPLOWABLE PAVEMENT MARKERS	
ME	YELLOW & YELLOW

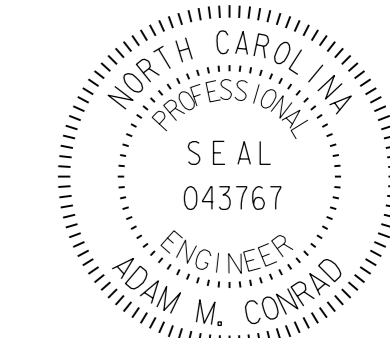
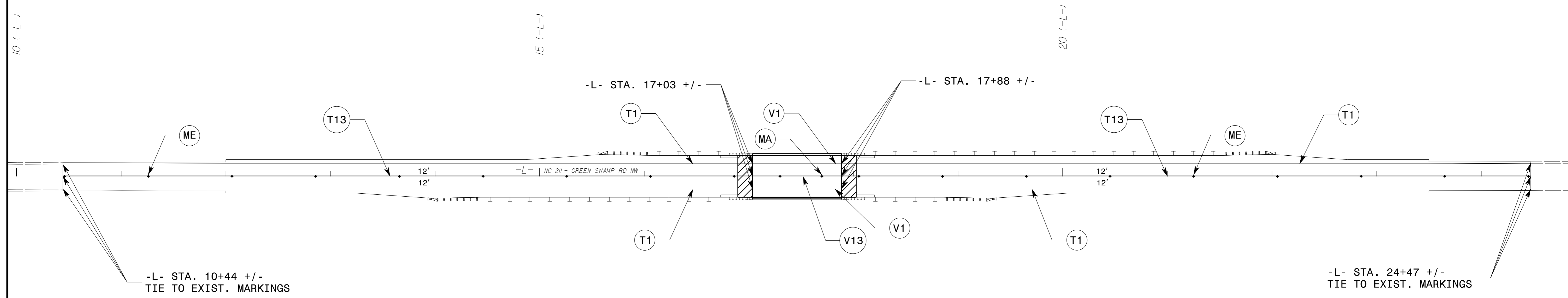
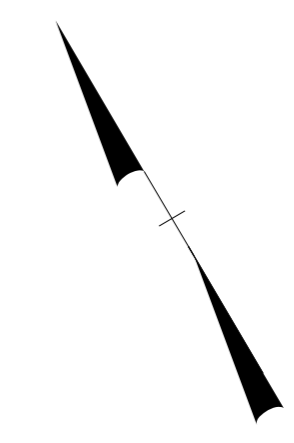

-SYSTEM: B-5624_TIP_PMP02.dgn
USER: B015011A

PAVEMENT MARKING DETAIL