

GEOTECHNICAL ENGINEER

Shane C. Clark  
4/22/2020

ENGINEER

\_\_\_\_\_  
SIGNATURE      DATE

**DOCUMENT NOT CONSIDERED FINAL  
UNLESS ALL SIGNATURES COMPLETED**

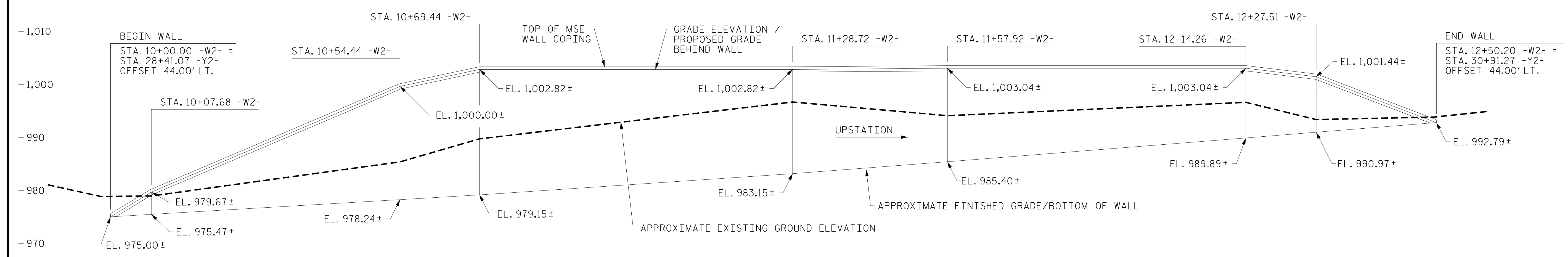
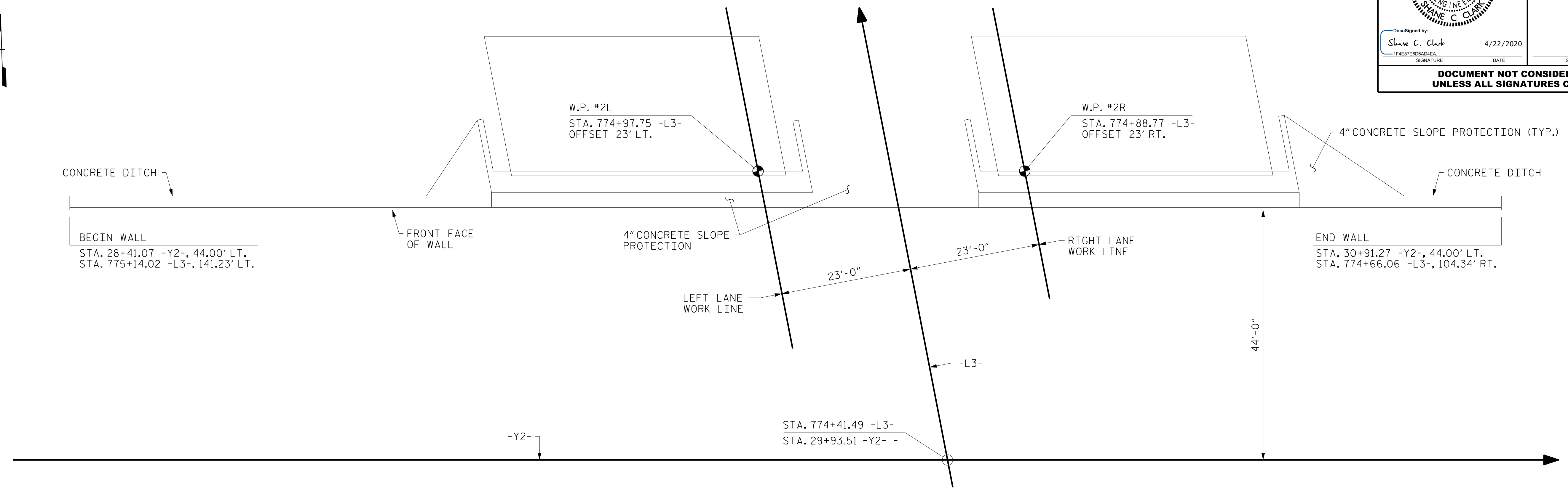

PROJECT NO.: 34400 (R-2233BB)

RUTHERFORD COUNTY

STATION: 29+93.51 -Y2-

SHEET 2 OF 5

MSE WALL QUANTITY (SQUARE FEET)	
MSE RETAINING WALL NO. 2	4,335 SF
* EST. QTY INCLUDES 2 FT EMBEDMENT	

**NORTH CAROLINA**  
**DEPARTMENT OF TRANSPORTATION**  
**DIVISION OF HIGHWAYS**  
  
**GEOTECHNICAL**  
**ENGINEERING UNIT**

BRIDGE NOS. 660 AND 661 ON -L3- OVER -Y2- RETAINING WALL NO. 2					
REVISIONS					
NO.	BY	DATE	NO.	BY	DATE
1	-	-	3	-	-
2	-	-	4	-	-

SHEET NO. W-2

PREPARED BY: SCC	DATE: 4/9/20
REVIEWED BY: ENW	DATE: 4/9/20