

TYPICAL SECTION AT INTERMEDIATE STEEL DIAPHRAGMS

* FOR INTERMEDIATE STEEL DIAPHRAGM DETAILS, SEE "INTERMEDIATE STEEL DIAPHRAGMS FOR TYPE IV PRESTRESSED CONCRETE GIRDERS" SHEET.

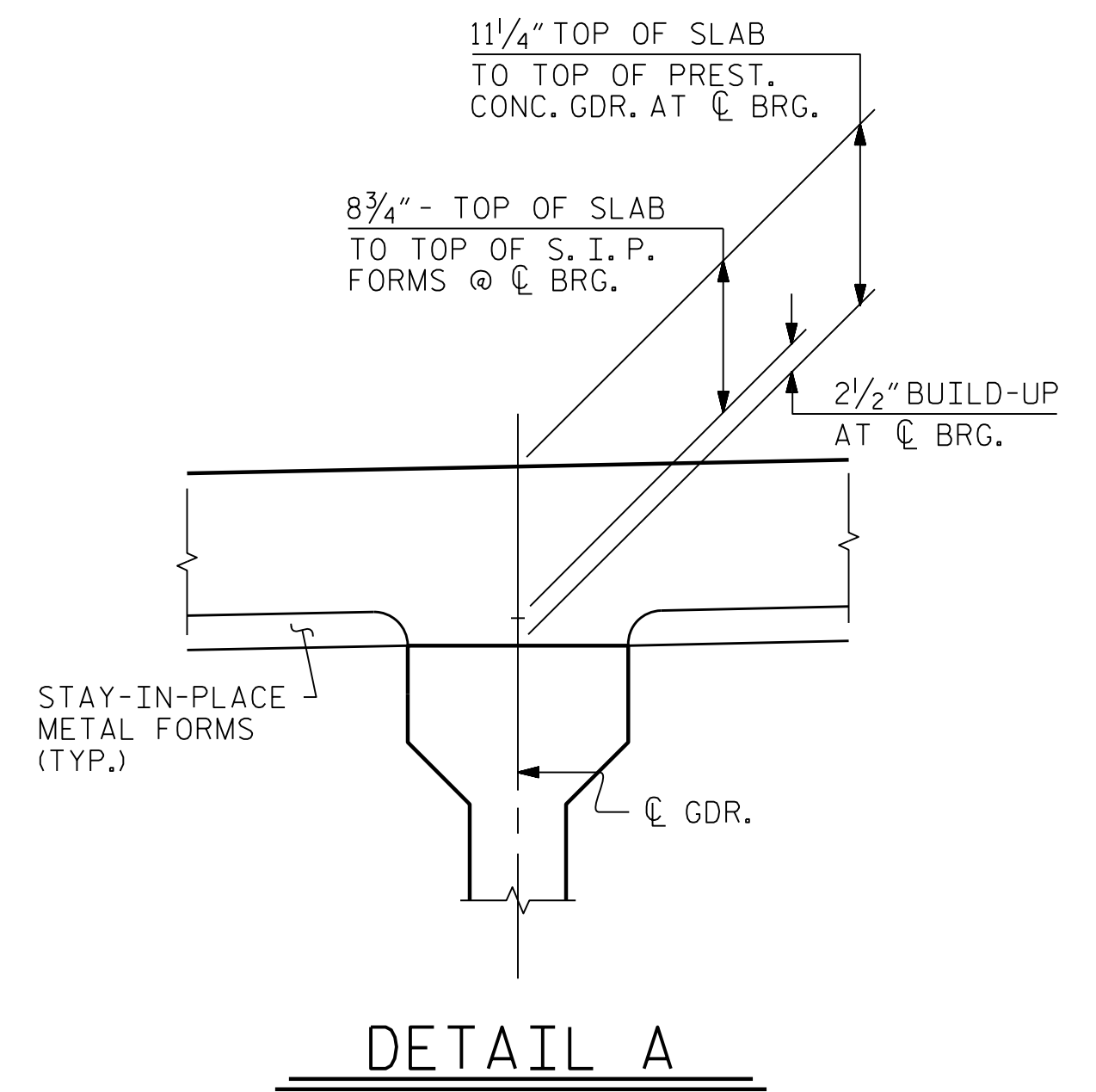

DETAIL A

PROJECT NO. R-2233BB
RUTHERFORD COUNTY
 STATION: 20+88.94 -Y19-

SHEET 2 OF 3

STATE OF NORTH CAROLINA
 DEPARTMENT OF TRANSPORTATION
 RALEIGH
 SUPERSTRUCTURE
 TYPICAL SECTION

MODJESKI and MASTERS
 Experience great bridges.
 333 FAYETTEVILLE STREET, SUITE 500
 RALEIGH, NC 27601
 NC LICENSE NO. C-2979

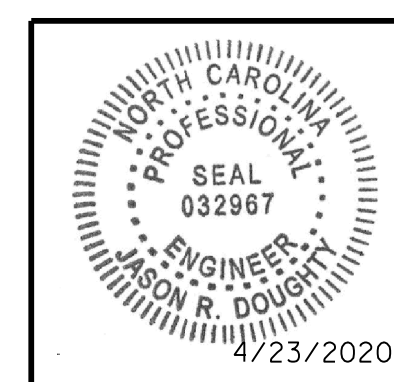

REVISIONS						SHEET NO.
NO.	BY:	DATE:	NO.	BY:	DATE:	S3-6
1			3			TOTAL SHEETS
2			4			34

DOCUMENT NOT CONSIDERED FINAL UNLESS ALL SIGNATURES COMPLETED

DocuSigned by:
 Jason R. Doughty
 SF73FA2DEA974E8...

STR. #3

4/22/2020 403.011.R2233BB_SWL_TYP2_800662.dgn

DESIGNED BY:	C. CORMAN	DATE:	APR 2019
DRAWN BY:	K. WHITE	DATE:	MAR 2019
CHECKED BY:	J. BORUTA	DATE:	AUG 2019
DESIGN ENGINEER OF RECORD:	J. DOUGHTY	DATE:	NOV 2019