

PLAN @ END BENT 1 **PLAN @ END BENT 2**
 DIMENSIONS SHOWN ARE TYPICAL FOR BOTH APPROACH SLABS
 * RADIAL DIMENSION
 ** 100°54'37" (TO LONG CHORD) SEE "LONG CHORD LAYOUT" SHEET FOR ADDITIONAL INFORMATION

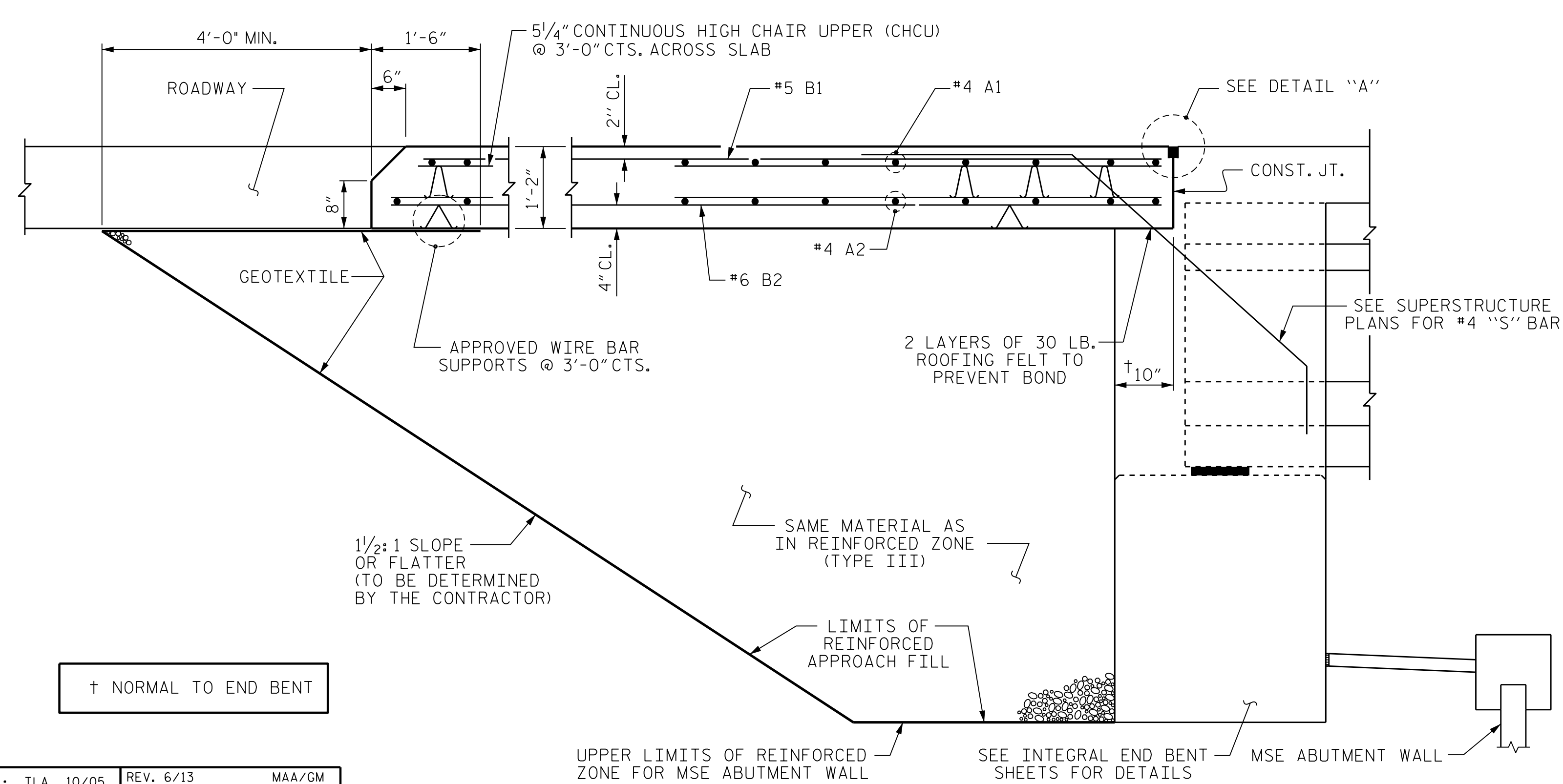

SECTION THRU SLAB
 (TYPE III - REINFORCED APPROACH FILL)

NOTES

APPROACH SLAB SHALL NOT BE CONSTRUCTED PRIOR TO COMPLETION OF THE BRIDGE DECK.

FOR BRIDGE APPROACH FILL INCLUDING GEOTEXTILE, MSE WALL REINFORCEMENT AND BACKWALL MATERIAL, SEE ROADWAY PLANS.

GEOTEXTILE SHALL BE TYPE 1 IN ACCORDANCE WITH THE STANDARD SPECIFICATIONS SECTION 1056.

BACKFILL MATERIAL SHALL BE THE SAME MATERIAL USED IN THE MSE REINFORCED ZONE.

THE JOINT OPENING AT THE APPROACH SLAB/DECK INTERFACE SHALL BE SAWED NO MORE THAN 12 HOURS AFTER THE APPROACH SLAB IS CAST. THE JOINT SHALL BE CLEANED OF ALL DEBRIS BEFORE THE SEALANT IS APPLIED. THE JOINT SEALER MATERIAL SHALL CONFORM TO THE REQUIREMENTS OF SECTION 1028-3 OF THE STANDARD SPECIFICATIONS.

AREA BETWEEN THE WINGWALL AND APPROACH SLAB SHALL BE GRADED TO DRAIN THE WATER AWAY FROM THE FILL FACE OF THE BRIDGE AND SHALL BE PAVED. SEE ROADWAY PLANS.

BILL OF MATERIAL
 FOR ONE APPROACH SLAB
 (2 REQ'D)

BAR	NO.	SIZE	TYPE	LENGTH	WEIGHT
* A1	52	#4	STR	24'-11"	866
A2	52	#4	STR	24'-9"	860
* B1	94	#5	STR	24'-2"	2369
B2	94	#6	STR	24'-6"	3459
REINFORCING STEEL					LBS. 4319
* EPOXY COATED REINFORCING STEEL					LBS. 3235
CLASS AA CONCRETE					C. Y. 51.1

SPLICE LENGTHS

BAR SIZE	EPOXY COATED	UNCOATED
#4	1'-11"	1'-7"
#5	2'-5"	2'-0"
#6	3'-7"	2'-5"

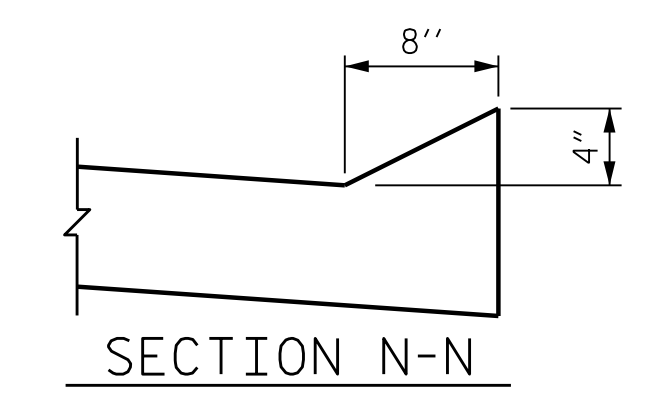
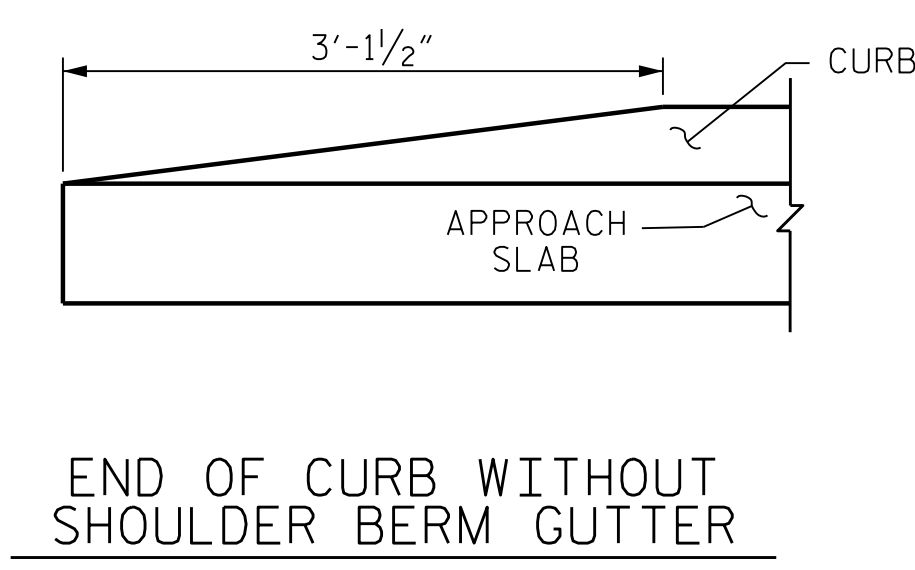
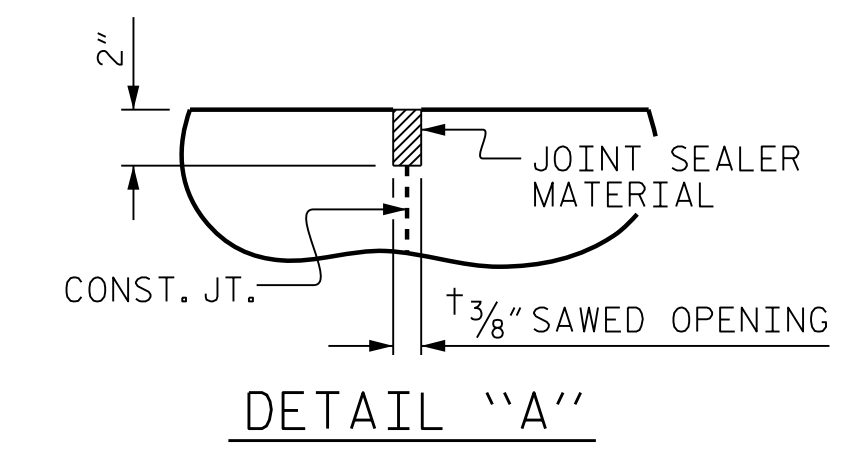

PROJECT NO. R-2233BB
RUTHERFORD COUNTY
 STATION: 774+41.49 -L3-
 SHEET 1 OF 2

STATE OF NORTH CAROLINA
 DEPARTMENT OF TRANSPORTATION
 RALEIGH

STANDARD
BRIDGE APPROACH SLAB FOR INTEGRAL ABUTMENT

REVISIONS

NO.	BY:	DATE:	NO.	BY:	DATE:
1			3		
2			4		

SHEET NO. **S2-27**
 TOTAL SHEETS 28

STR. #2 STD. NO. BAS5 1b

MODJESKI and MASTERS
 Experience great bridges.

333 FAYETTEVILLE STREET, SUITE 500
 RALEIGH, NC 27601
 NC LICENSE NO. C-2979

DocuSigned by:
Jason R. Dougherty
 5F73FA2DEA874E8...

DOCUMENT NOT CONSIDERED FINAL UNLESS ALL SIGNATURES COMPLETED

4/22/2020
 402_053_R2233BB_SML_AS1_800661JDCN

DRAWN BY: TLA	10/05	REV. 6/13	MAA/GM
CHECKED BY: GM	5/06	REV. 12/17	MAA/THC
		REV. 06/19	BNB/THC

DESIGNED BY: CCC/K. WHITE DATE: AUG 2019
 DRAWN BY: K. WHITE DATE: AUG 2019
 CHECKED BY: J. BORUTA DATE: AUG 2019
 DESIGN ENGINEER OF RECORD: J. DOUGHTY DATE: NOV 2019