

SECTION A-A

* FOR S7 BARS, SEE DETAIL "A" OF PRESTRESSED CONCRETE GIRDER CONTINUOUS FOR LIVE LOAD DETAILS SHEET

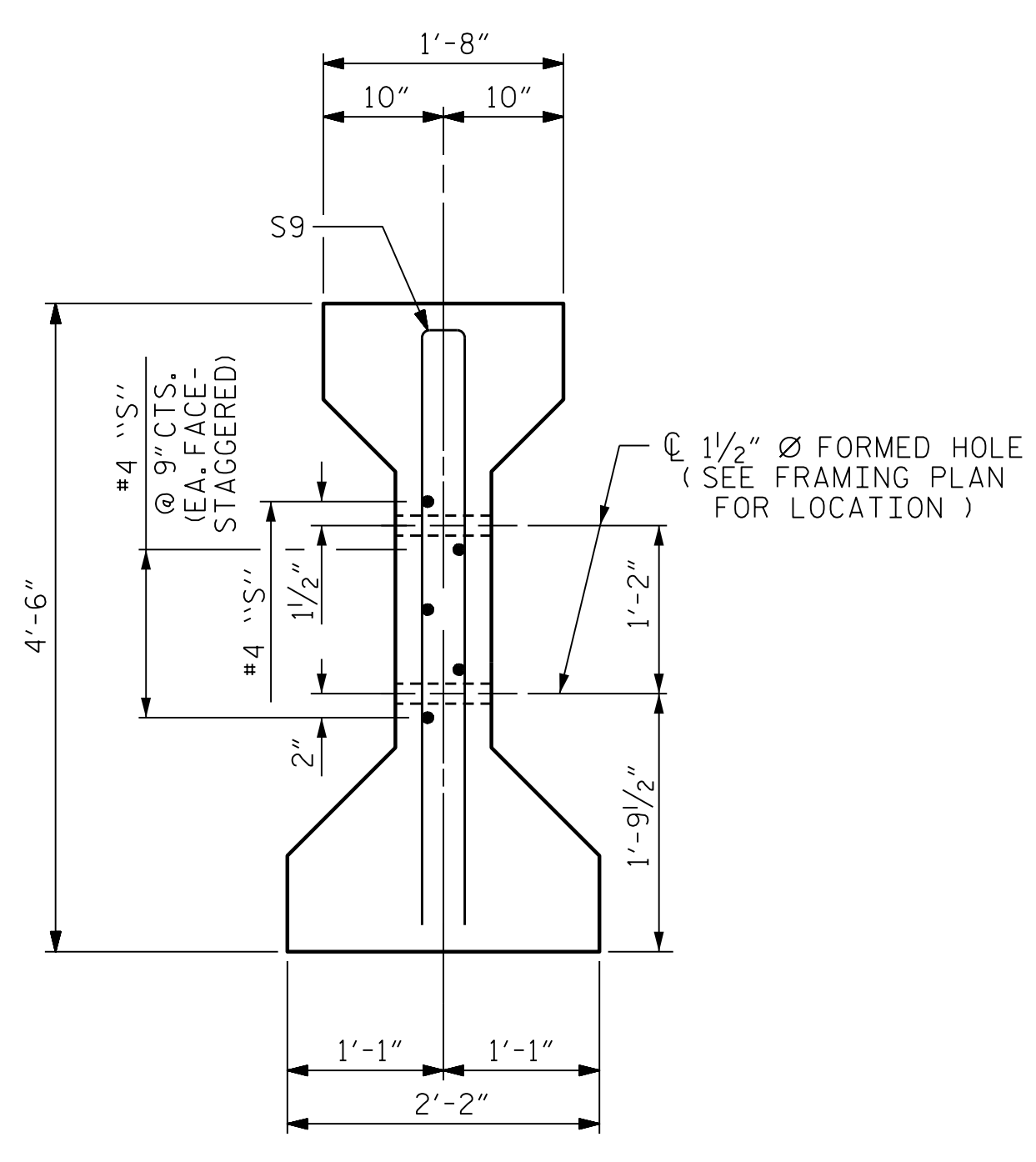

SECTION C-C
(S1 BARS NOT SHOWN)

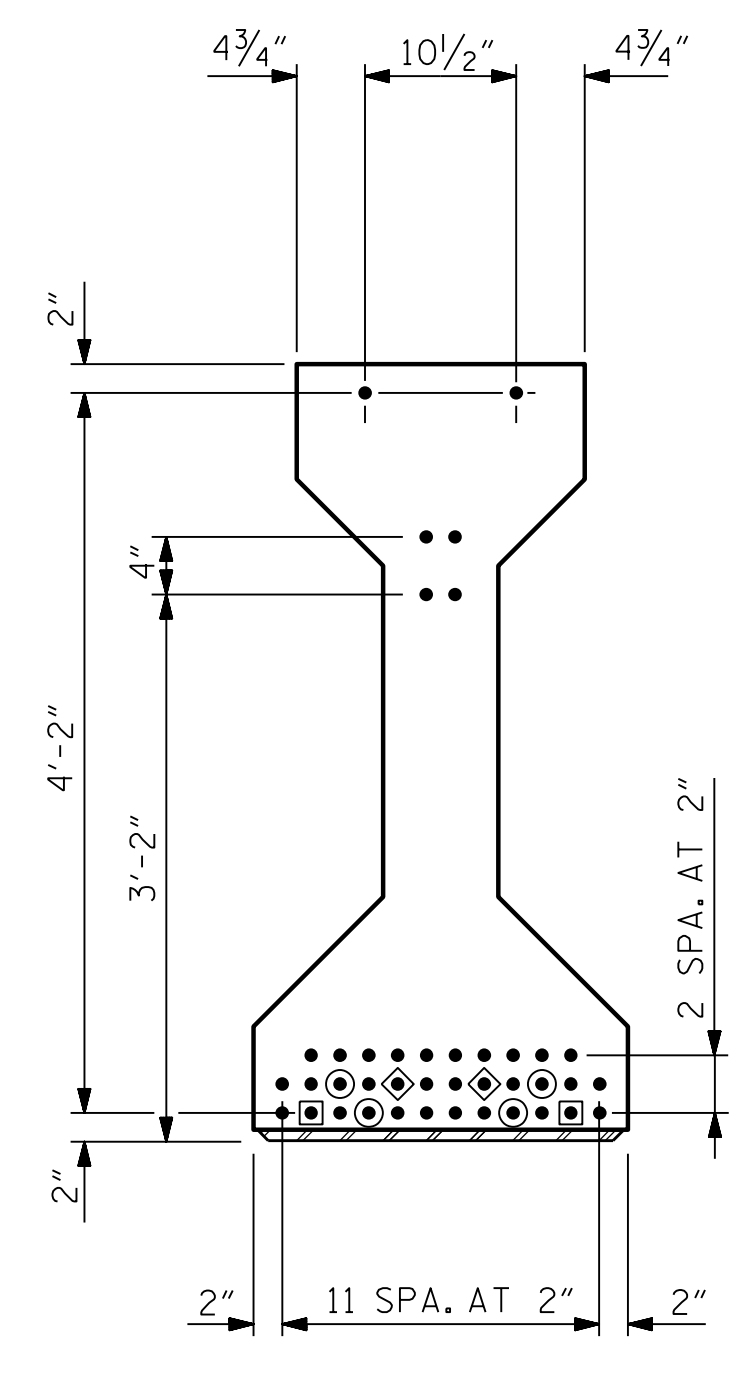

AT END OF GIRDER

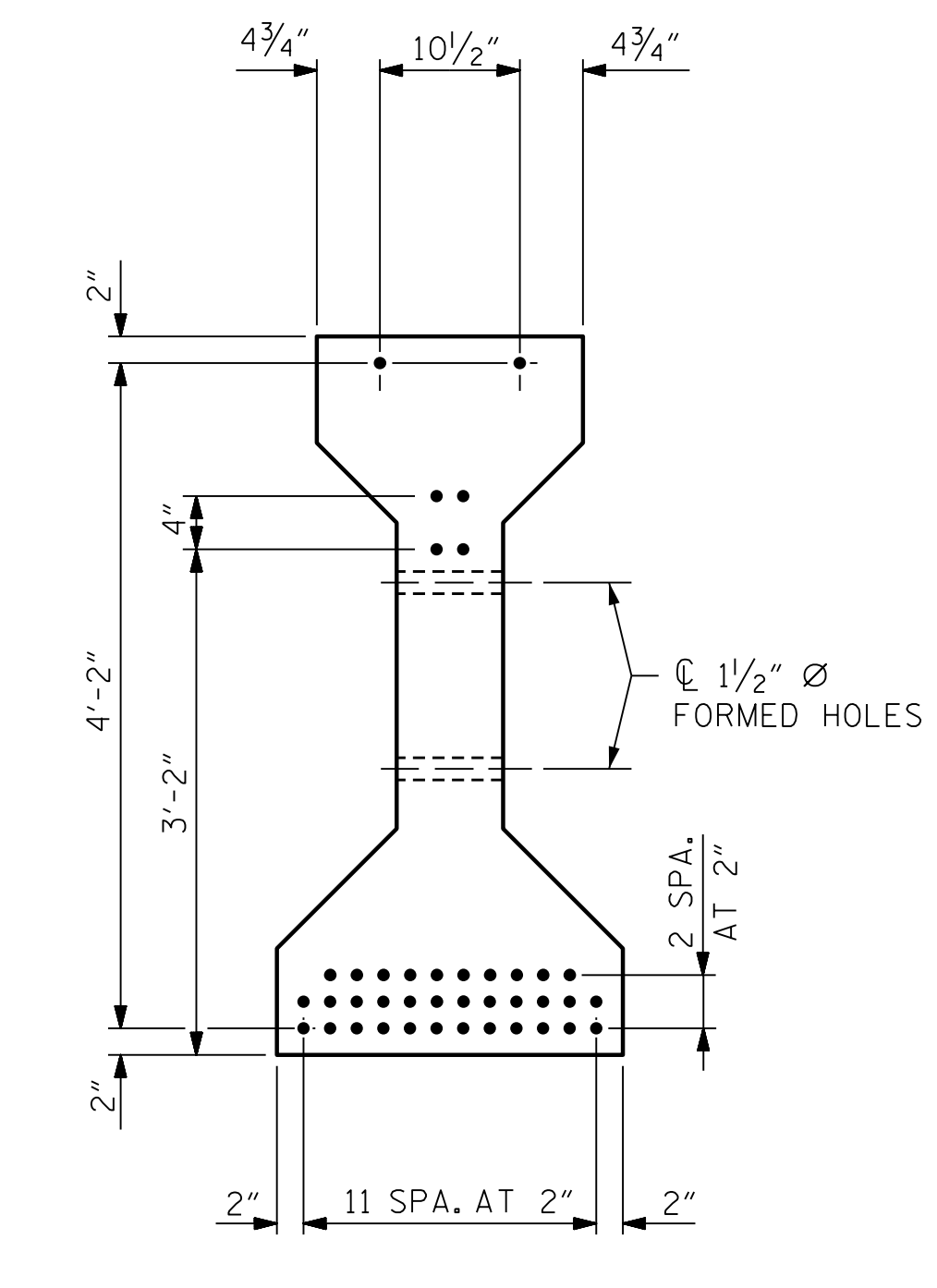

AT C OF GIRDER

0.6" Ø LOW RELAXATION STRAND LAYOUT

DEBONDING LEGEND

- FULLY BONDED STRANDS.
- STRANDS DEBONDED FOR 10'-0" FROM END OF GIRDER.
- ⊙ STRANDS DEBONDED FOR 8'-0" FROM END OF GIRDER.
- ◆ STRANDS DEBONDED FOR 6'-0" FROM END OF GIRDER.

0.6" Ø L. R. GRADE 270 STRANDS		
AREA (SQUARE INCHES)	ULTIMATE STRENGTH (LBS. PER STRAND)	APPLIED PRESTRESS (LBS. PER STRAND)
0.217	58,600	43,950

REINFORCING STEEL FOR ONE GIRDER

BAR	NUMBER	SIZE	TYPE	LENGTH	WEIGHT
S1	76	#4	1	10'-9"	546
S2	22	#6	1	10'-9"	355
S3	4	#4	2	9'-1"	24
S4	80	#4	3	3'-5"	183
S5	6	#4	2	8'-5"	34
S6	4	#4	2	8'-7"	23
S7	24	#5	STR	3'-8"	92
S8	2	#3	STR	1'-10"	1
S9	2	#5	2	8'-8"	18
S10	5	#4	STR	7'-0"	23
S11	2	#3	STR	1'-4"	1

* NOTE: S7 BARS SHALL BE BENT BEFORE SHIPMENT. HEAT BENDING SHALL NOT BE ALLOWED.

BAR TYPES

ALL BAR DIMENSIONS ARE OUT-TO-OUT

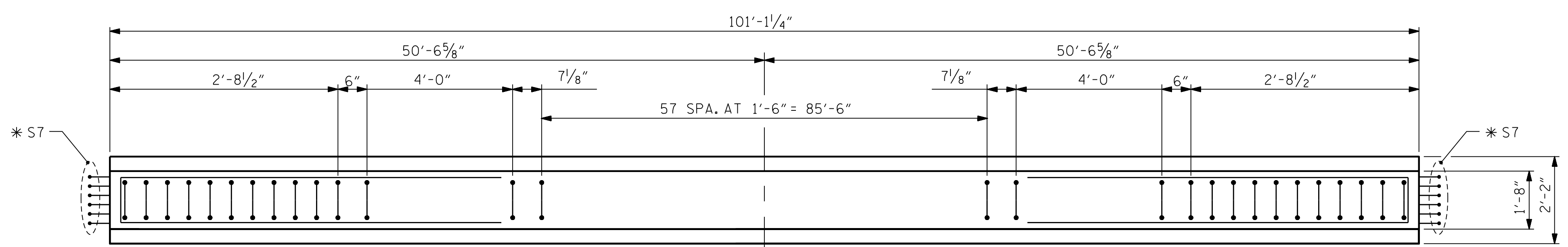
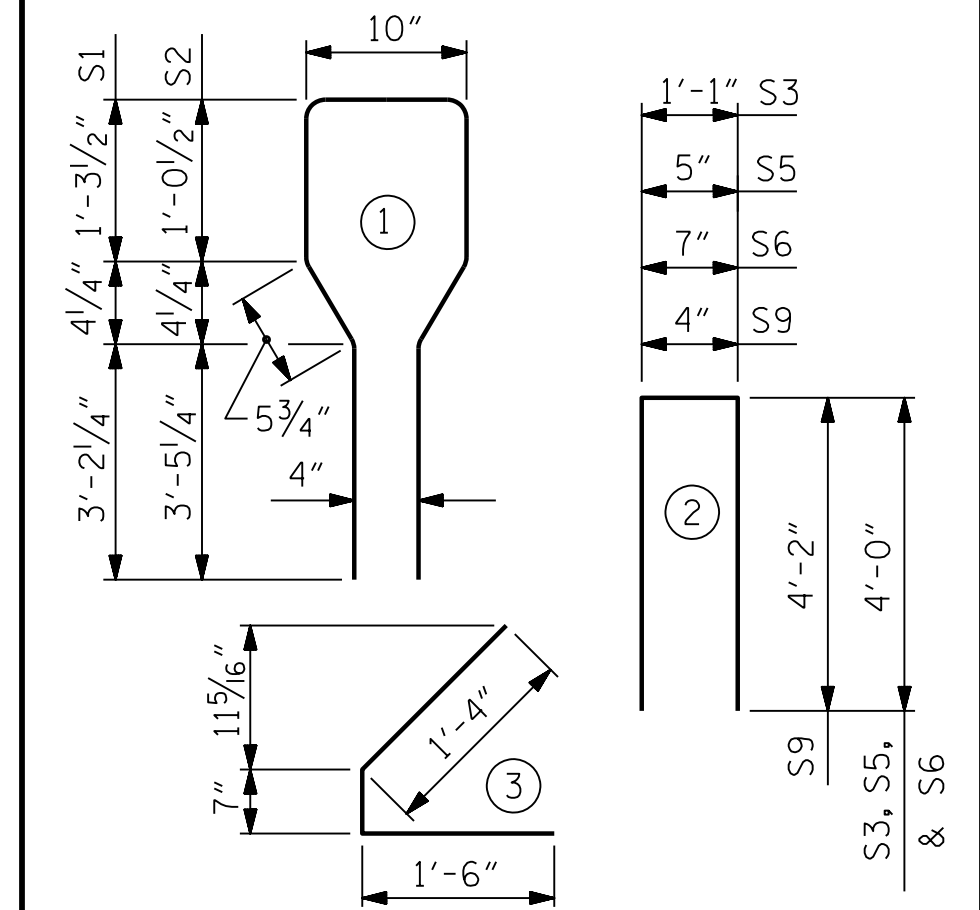

PLAN OF GIRDER

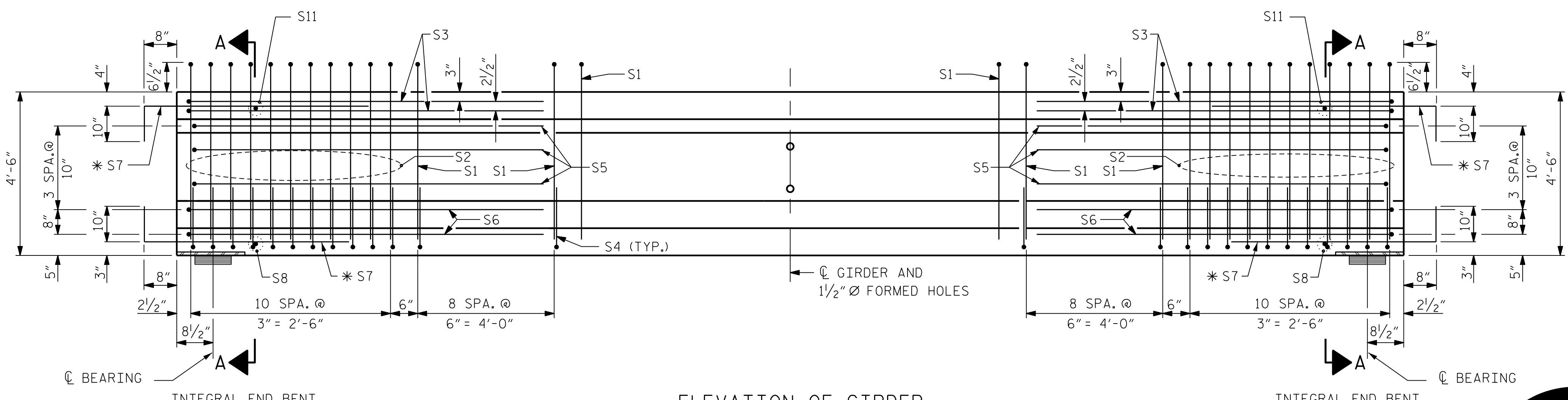

ELEVATION OF GIRDER

(SEE PARTIAL ELEVATION FOR ADDITIONAL "S" BARS)

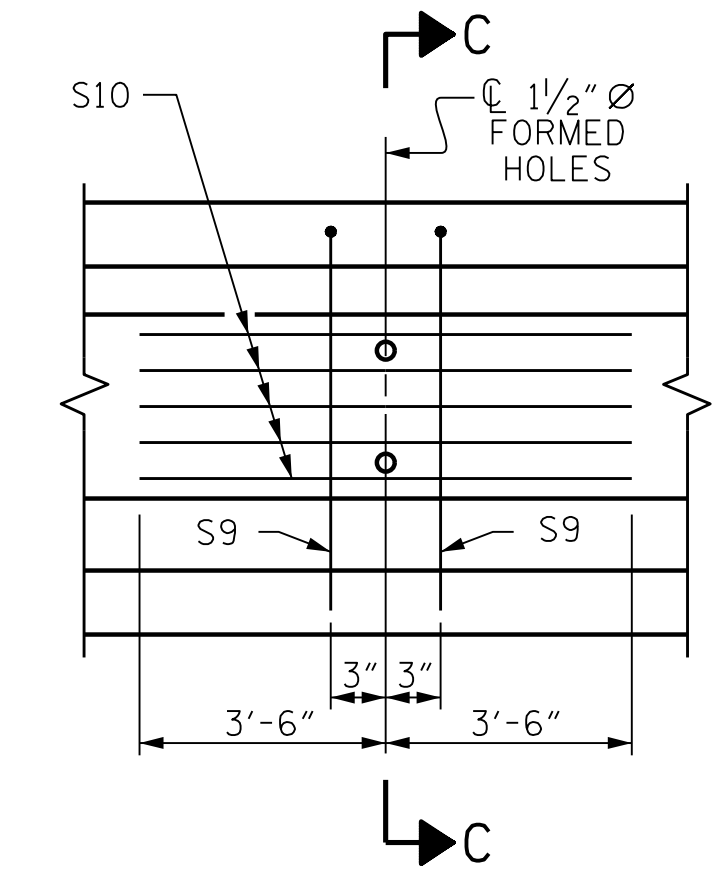

PARTIAL ELEVATION

SHOWING INTERMEDIATE DIAPHRAGM REINFORCING STEEL FOR ALL GIRDERS.

QUANTITIES FOR ONE GIRDER

	REINFORCING STEEL	7500 PSI CONCRETE	0.6" Ø L. R. STRANDS
	LB.	C.Y.	No.
54" PCG GIRDER	1300	20.5	40

GIRDERS REQUIRED

NUMBER	LENGTH	TOTAL LENGTH
6	101'-1 1/4"	606.63'

PROJECT NO. R-2233BB
RUTHERFORD COUNTY
 STATION: 774+41.49 -L3-

DRAWN BY: ELR 8/91	REV. 10/1/11	MAA/GM
CHECKED BY: GRP 8/91	REV. 1/15	MAA/TMG
	REV. 12/17	MAA/THC
DESIGNED BY: C. CORMAN	DATE: JULY 2019	
DRAWN BY: K. WHITE	DATE: JULY 2019	
CHECKED BY: J. BORUTA	DATE: AUG 2019	
DESIGN ENGINEER		
OF RECORD: J. DOUGHTY	DATE: NOV 2019	

MODJESKI and MASTERS
 Experience great bridges.
 333 FAYETTEVILLE STREET, SUITE 500
 RALEIGH, NC 27601
 NC LICENSE NO. C-2979

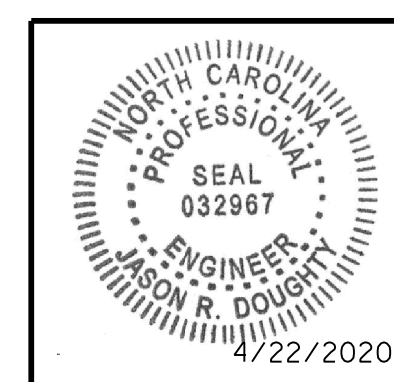

STATE OF NORTH CAROLINA
 DEPARTMENT OF TRANSPORTATION
 RALEIGH
 STANDARD
**AASHTO TYPE IV
 PRESTRESSED
 CONCRETE GIRDER**
 SPAN A

REVISIONS				SHEET NO.	
NO.	BY:	DATE:	NO.	BY:	DATE:
1			3		
2			4		

TOTAL SHEETS: 28

**DOCUMENT NOT CONSIDERED FINAL
 UNLESS ALL SIGNATURES COMPLETED**