

NOTES:

CONSTRUCT PROPOSED STEEL PIPE RAIL 1 1/2" DIAMETER SCHEDULE 40 PLAIN END GALVANIZED STEEL PIPE MEETING THE REQUIREMENTS OF ASTM A53.

EMBED PIPE RAIL INTO PROPOSED HEADWALLS AND WINGS AS SHOWN ON THE PLANS AND GROUT INTO PLACE. FOR GROUT, SEE SPECIAL PROVISIONS.

REPAIR GALVANIZING IN ACCORDANCE WITH SECTION 1076 OF THE NCDOT STANDARD SPECIFICATIONS.

WELD IN ACCORDANCE WITH ARTICLE 1072-18 OF THE STANDARD SPECIFICATIONS.

FOR GALVANIZED RAILS, SEE SPECIAL PROVISIONS.

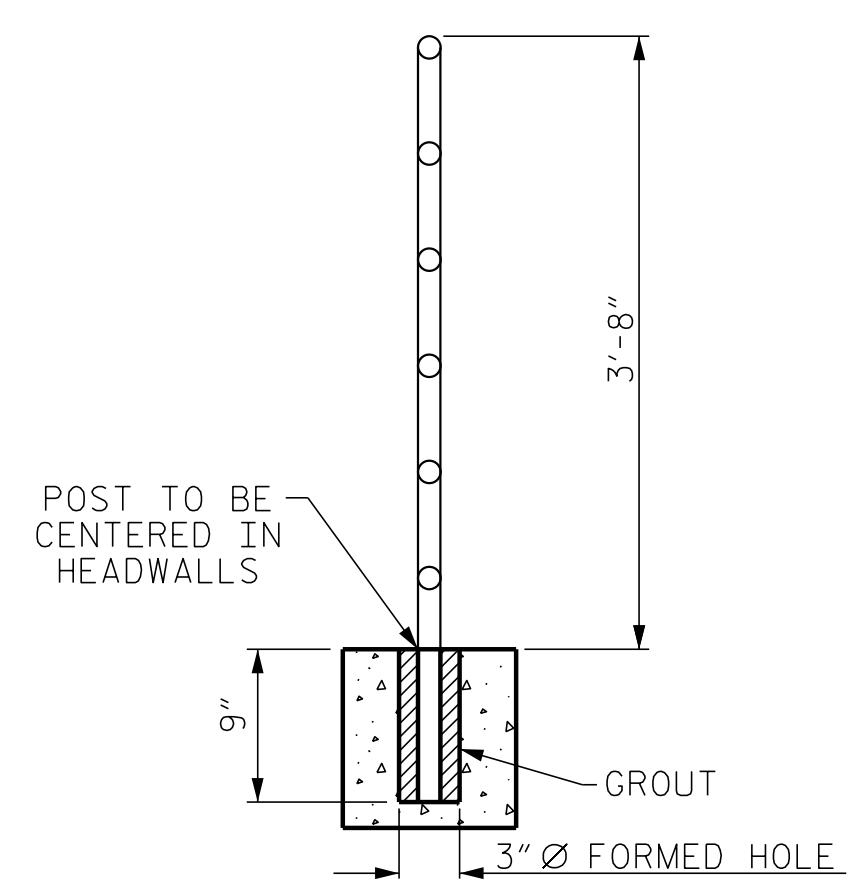

INSET 'A'

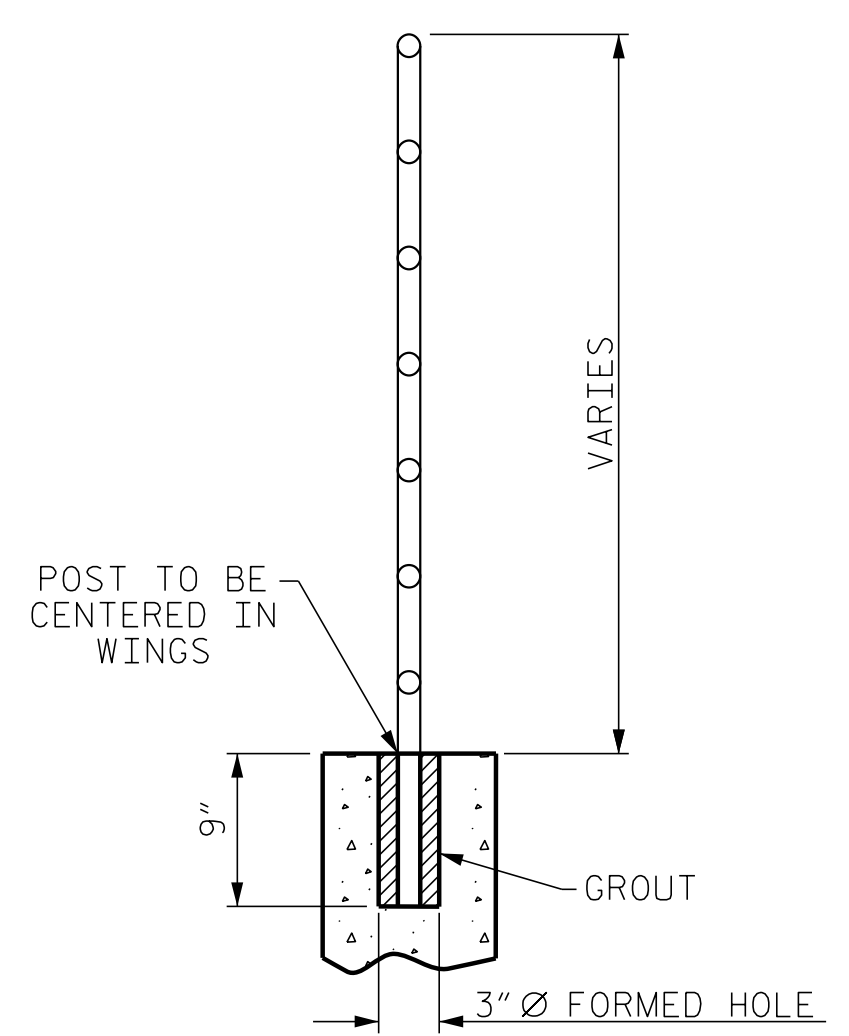

INSET 'B'

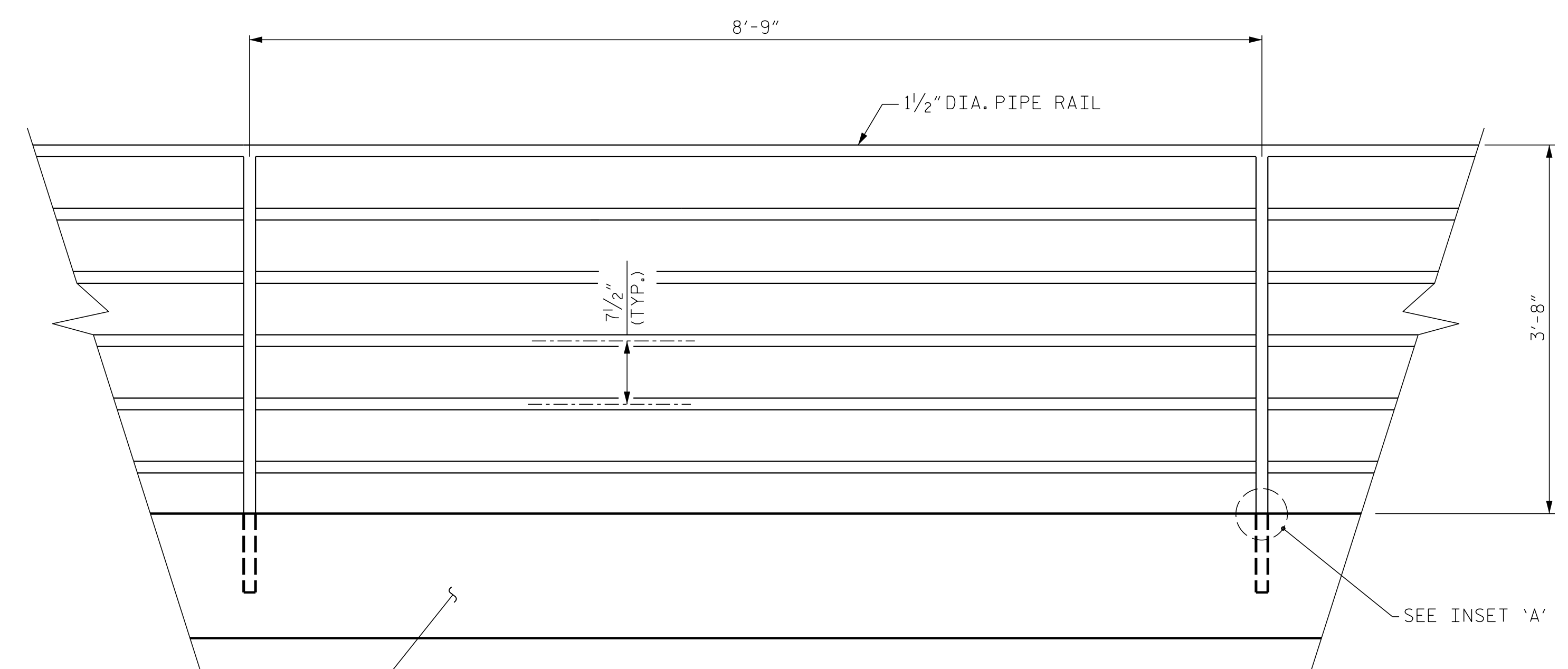

ELEVATION OF RAIL AT HEADWALLS

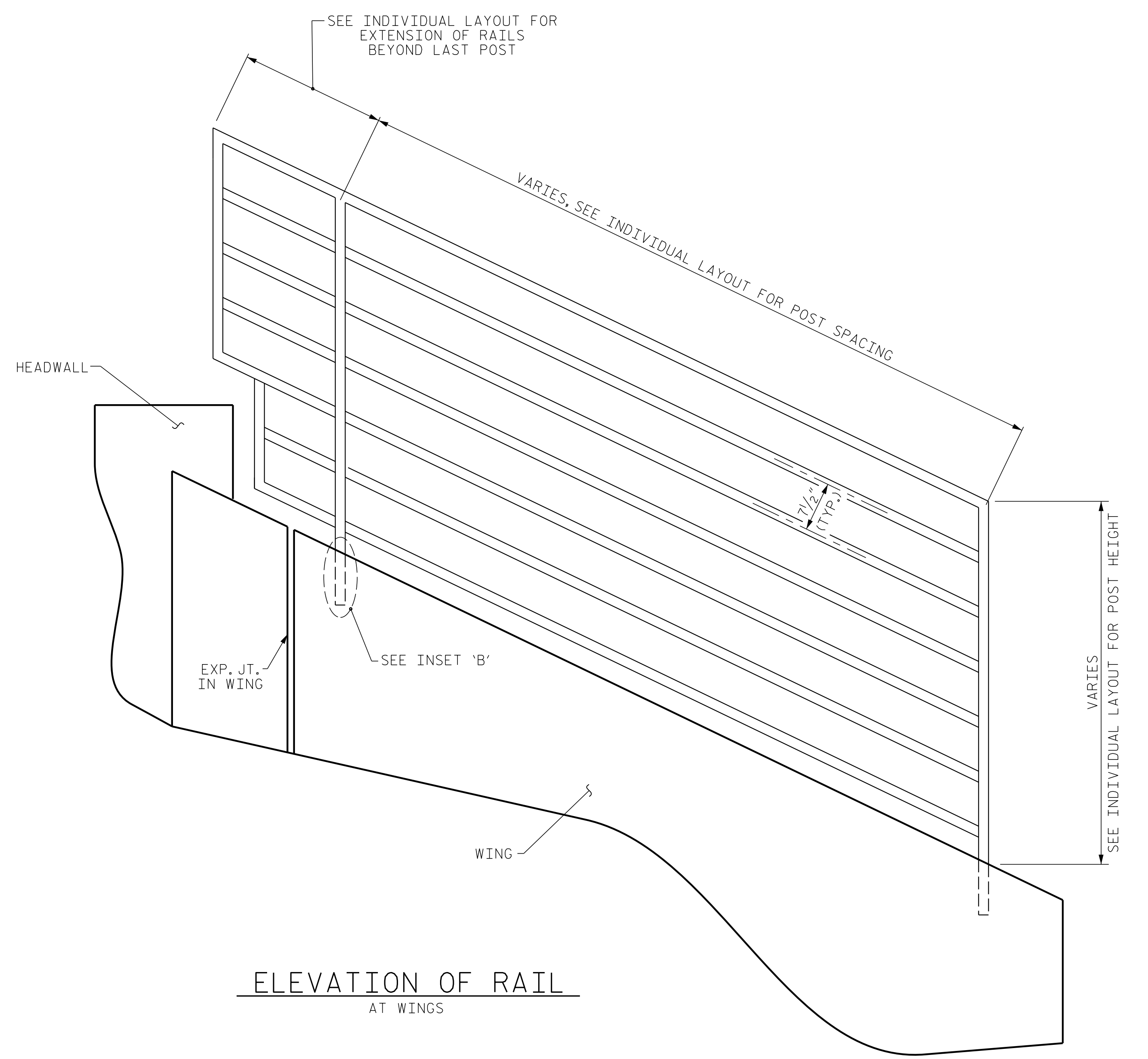

ELEVATION OF RAIL AT WINGS

PAY ITEM	
GALVANIZED RAILS	164.88 LIN. FT.

PROJECT NO. U-5888
HAYWOOD COUNTY
 STATION: 14+99.00 -Y4-

SHEET 11 OF 11

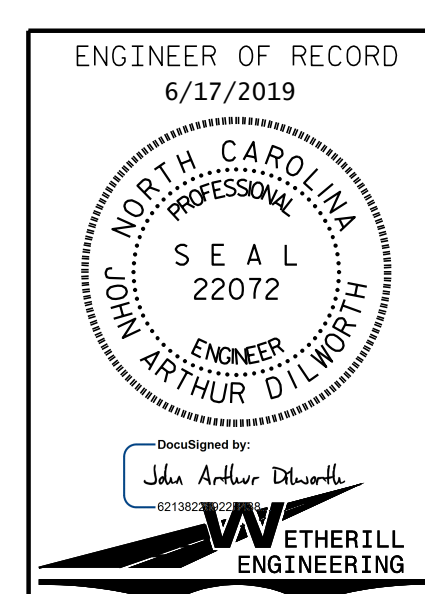

1223 Jones Franklin Rd.
 Raleigh, N.C. 27606
 Bus: 919 851 8077
 Fax: 919 851 8107
 LICENSE NO. F-6377

STATE OF NORTH CAROLINA
 DEPARTMENT OF TRANSPORTATION
 RALEIGH

RAIL DETAILS

REVISIONS						SHEET NO.
NO.	BY:	DATE:	NO.	BY:	DATE:	C11
1			3			TOTAL SHEETS
2			4			11

DOCUMENT NOT CONSIDERED FINAL
 UNLESS ALL SIGNATURES COMPLETED

P:\2016\16133.01_U-5888\Structures\DWG\U-5888_SMU_CUL.dgn
 6/17/2019 10:19:30 AM

DRAWN BY: B.C. HUNT DATE: 1-19
 CHECKED BY: D.A. HODGE DATE: 2-19