

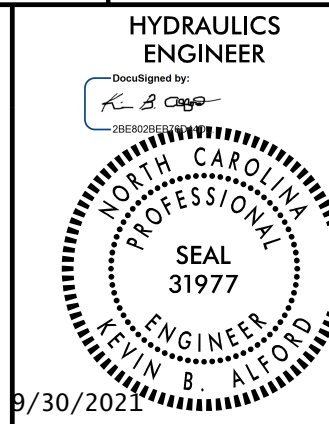

PROJECT REFERENCE NO. U-5888	SHEET NO. 2D-1
HYDRAULICS ENGINEER  SEAL 31977 9/30/2024	
DOCUMENT NOT CONSIDERED FINAL UNLESS ALL SIGNATURES COMPLETED	
 1223 Jones Franklin Rd. Raleigh, N.C. 27606 License No. F-0377 Bus: 919 851 8077 Fax: 919 851 8107	
TRANSPORTATION PLANNING/DESIGN - BRIDGE/STRUCTURE DESIGN CIVIL/SITE DESIGN - GIS/GPS - CONSTRUCTION OBSERVATION	



FROM -L1- STA. 11+00 TO STA. 11+65 RT.
 FROM -Y5- STA. 13+00 TO STA. 14+29 LT.
 FROM -Y6- STA. 11+50 TO STA. 12+37 RT.

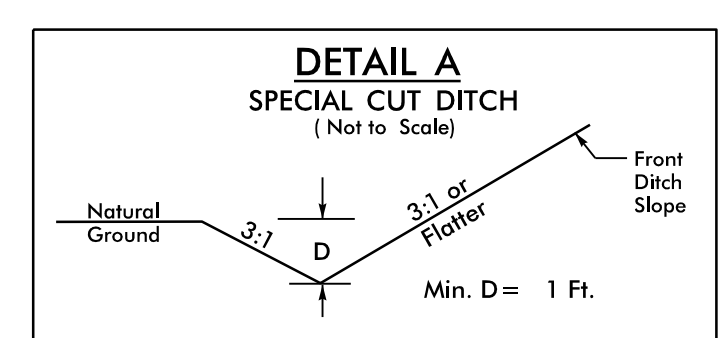
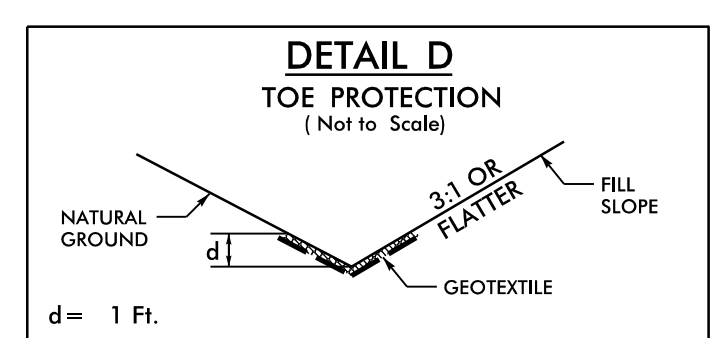

FROM -Y6- STA. 11+77 TO STA. 12+03 LT.

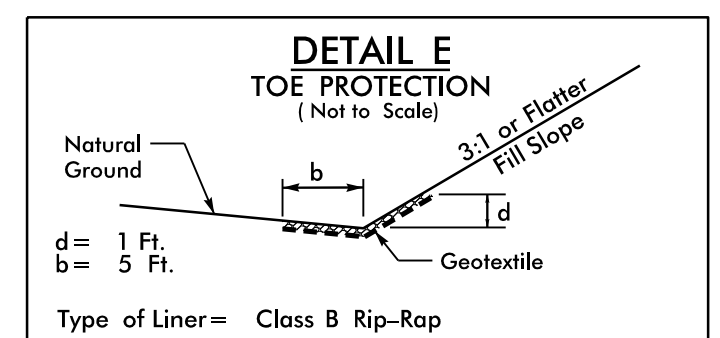

FROM -Y6- STA. 12+03 TO STA. 12+31 LT.

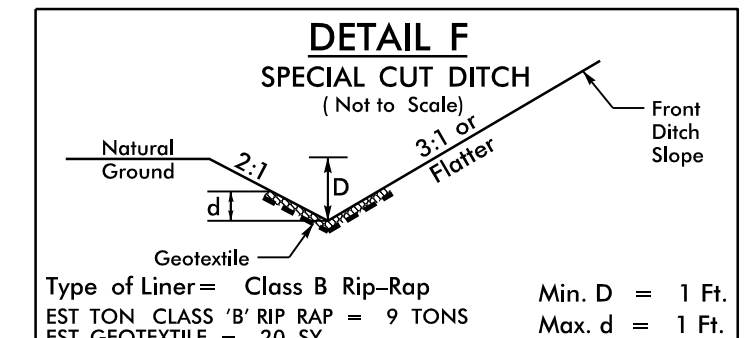

FROM -Y6- STA. 11+50 TO STA. 11+77 LT.

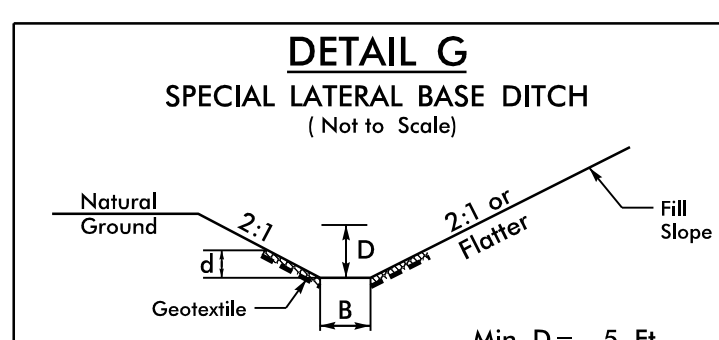

FROM -Y5- STA. 12+04 TO STA. 13+39 RT.

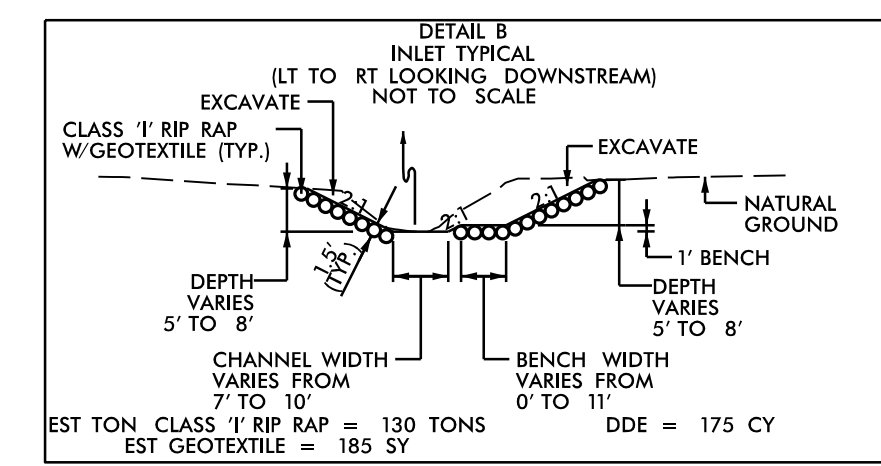

FROM -Y4- STA. 14+38 TO STA. 14+97 RT.

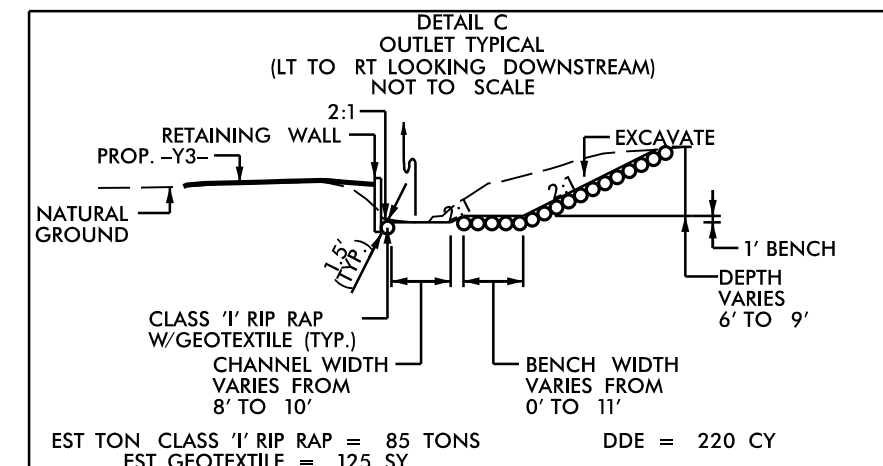

FROM -Y4- STA. 15+12 TO STA. 15+62 LT.

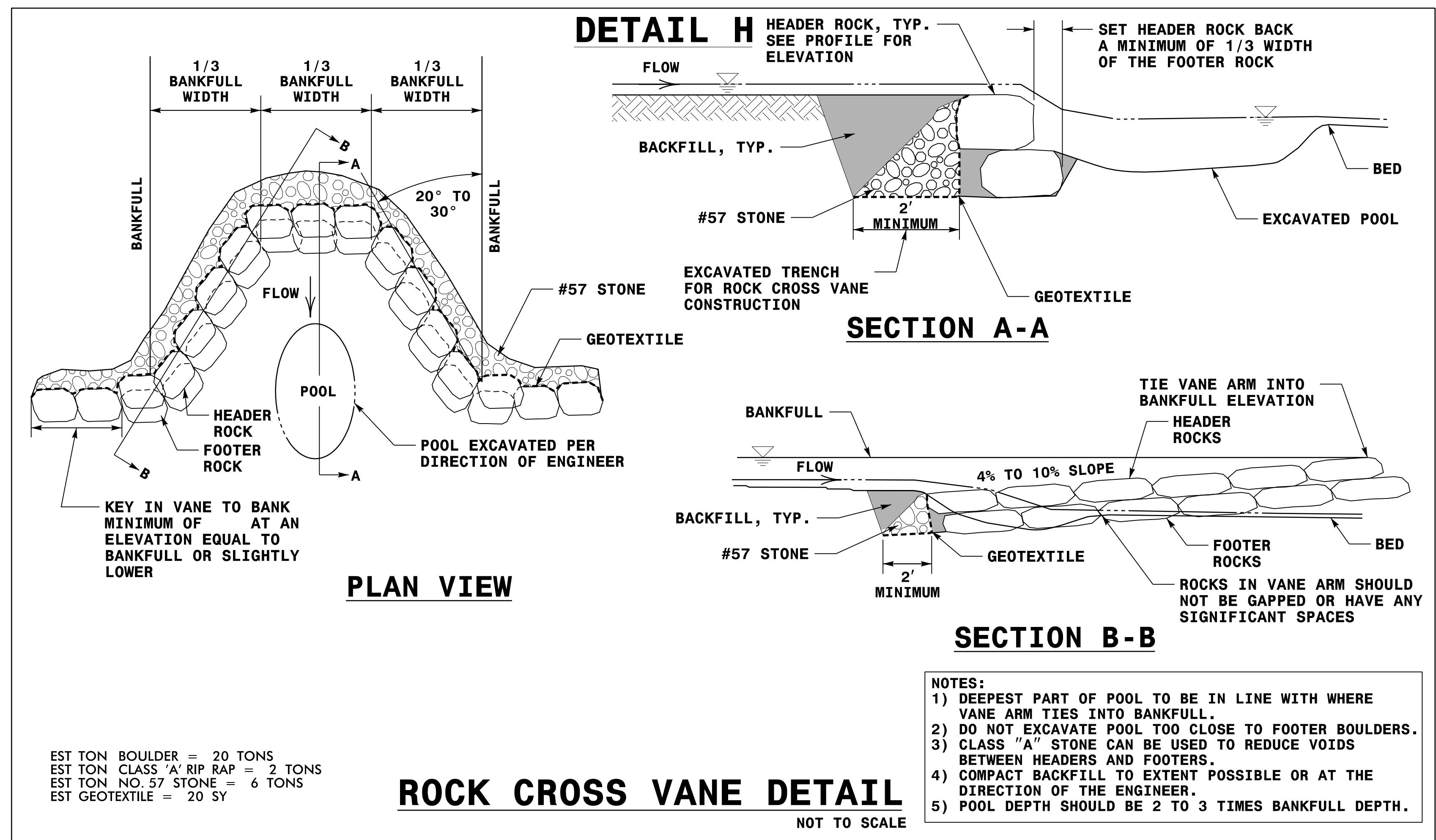

-Y5- STA. 12+07 RT.