

PLOT DRIVER: NCDOT_STRUCTURES_DEFAULT_PLOTTER.plt
 PENTABLE: NCDOT_STRUCTURES_DEFAULT_PEN.tbl
 USER: PPRETOSO DATE: 5/20/2021 TIME: 10:29:08 AM
 FILE: ...PLAN VIEW

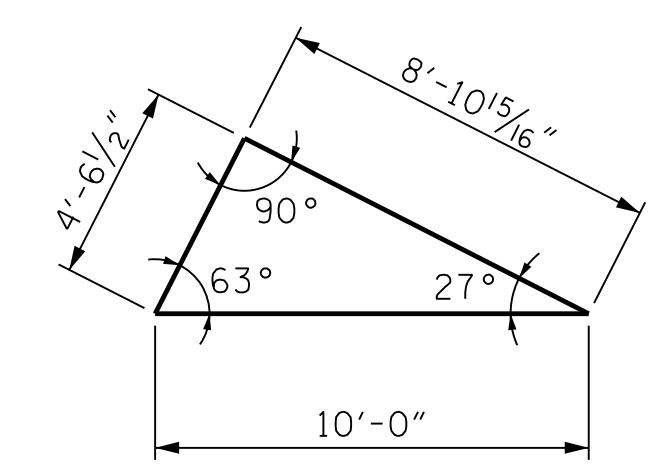
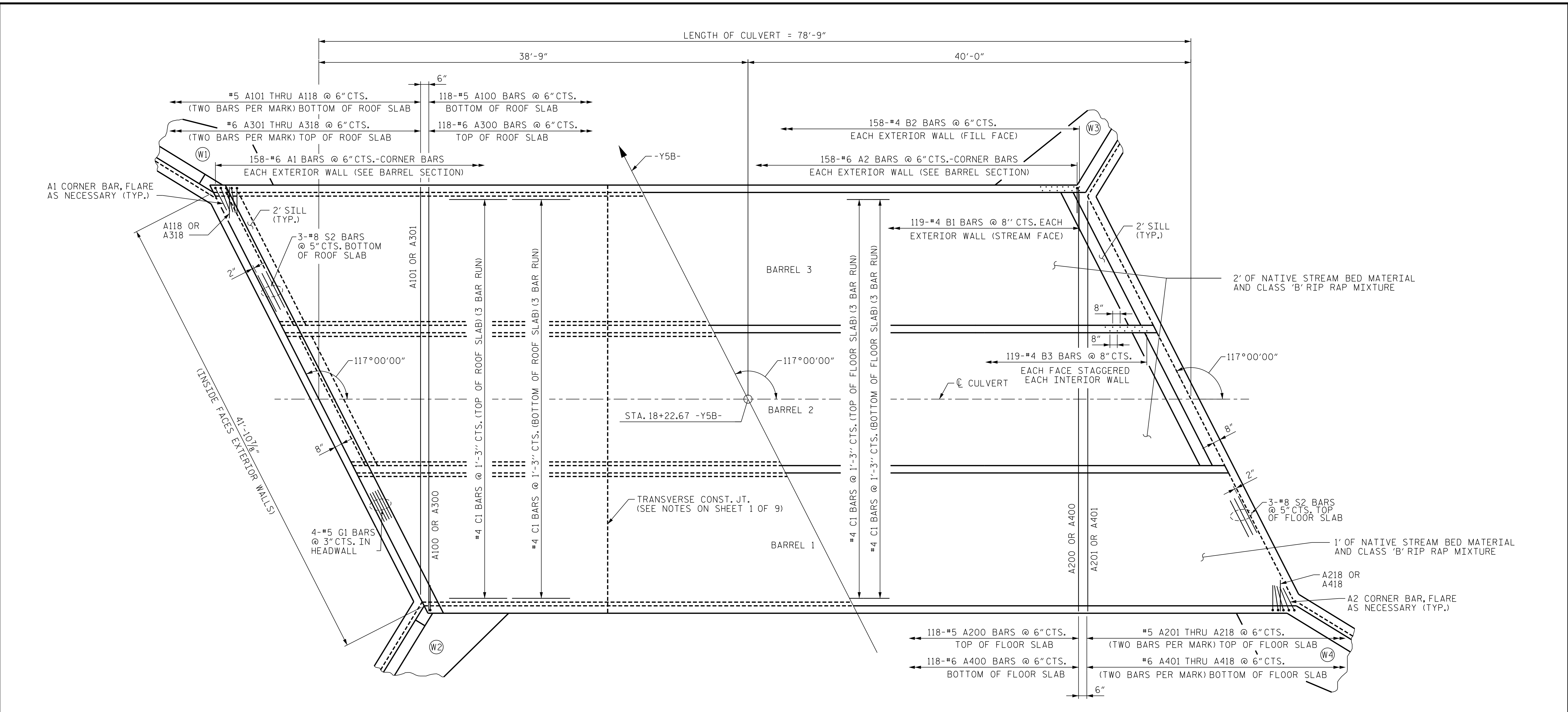

PART PLAN - ROOF SLAB

PART PLAN - FLOOR SLAB

PROJECT NO. U-2579AB
FORSYTH COUNTY
 STATION: 18+22.67 -Y5B-

SHEET 3 OF 9

I HEREBY CERTIFY THESE PLANS
ARE THE AS-BUILT PLANS

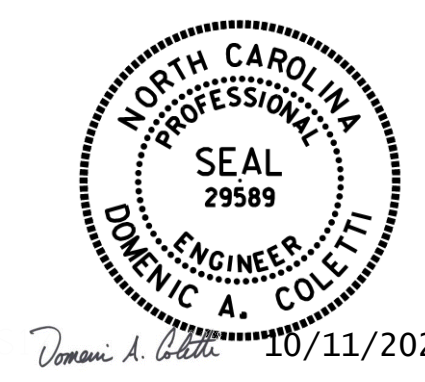

STATE OF NORTH CAROLINA
DEPARTMENT OF TRANSPORTATION
RALEIGH

**TRIPLE BARREL
12 FT. X 7 FT.
CONCRETE BOX CULVERT
117° SKEW**

REVISIONS					
NO.	BY:	DATE:	NO.	BY:	DATE:
1			3		
2			4		

SHEET NO. C5-3
TOTAL SHEETS 9

DES BY: <u>T. MCALEENAN</u>	DATE: <u>07/19</u>	DWG BY: <u>T. MCALEENAN</u>	DATE: <u>07/19</u>
DES CHK: <u>R. TURNAGE</u>	DATE: <u>07/19</u>	CHK BY: <u>R. TURNAGE</u>	DATE: <u>07/19</u>

HDR Engineering, Inc. of the Carolinas
 555 Fayetteville St., Suite 900 Raleigh, N.C. 27601
 N.C.B.E.L.S. License Number: F-0116

DOCUMENT NOT CONSIDERED FINAL
 UNLESS ALL SIGNATURES COMPLETED