

PLOT DRIVER: NCDOT... PENTABLE: NCDOT STRUCTURES DEFAULT PEN.tbl
 USER: PPETERSO DATE: 10/11/2021
 FILE: ...RATING SUMMARY

LOAD FACTORS:

DESIGN LOAD RATING FACTORS

LOAD TYPE	MAX FACTOR	MIN FACTOR
DC	1.25	0.90
DW	1.50	0.65
EV	1.30	0.90
EH	1.35	0.90
ES	1.35	0.90
WA	1.00	--

LOAD AND RESISTANCE FACTOR RATING (LRFR) SUMMARY FOR REINFORCED CONCRETE BOX CULVERTS										
	CONTROLLING LOAD RATING	MINIMUM RATING FACTOR (RF)	STRENGTH I LIMIT STATE							
			MOMENT				SHEAR			
			RATING FACTOR	BOX NO.	ELEMENT TYPE	DISTANCE FROM LEFT END OF ELEMENT (ft)	RATING FACTOR	BOX NO.	ELEMENT TYPE	DISTANCE FROM LEFT END OF ELEMENT (ft)
PERMANENT LOAD RATING	1	1.36	1.39	1	BOTTOM SLAB	3.75	1.36	1	EXTERIOR WALL	1.54

NOTES:
 RATING FACTORS ARE BASED ON THE STRENGTH I LIMIT STATE.
 THE EFFECTS OF LIVE LOAD ON DESIGN AND LOAD RATING MAY BE NEGLECTED FOR CULVERTS WITH CERTAIN FILL DEPTHS DESCRIBED IN THE AASHTO LRFD BRIDGE DESIGN SPECIFICATIONS.
 CULVERTS WITH NEGLIGIBLE LIVE LOAD SHOULD BE LOAD RATED FOR PERMANENT LOADS ONLY IN ACCORDANCE WITH THE AASHTO MANUAL FOR BRIDGE EVALUATION.

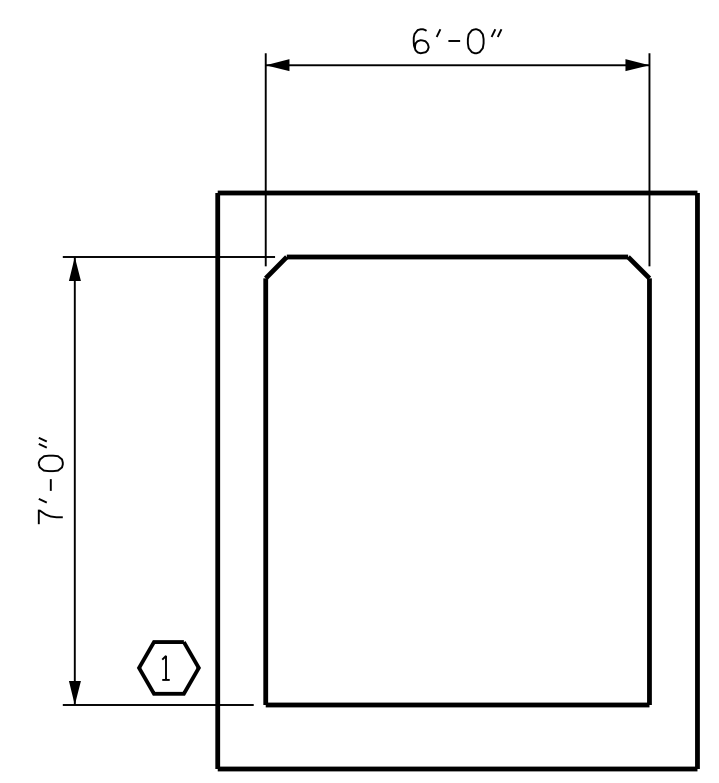

LRFR SUMMARY
(LOOKING DOWN STREAM)

PROJECT NO. U-2579AB
FORSYTH COUNTY
 STATION: 792+88.12 -L-
 SHEET 6 OF 6

STATE OF NORTH CAROLINA
 DEPARTMENT OF TRANSPORTATION
 RALEIGH

LRFR SUMMARY FOR
 REINFORCED CONCRETE
 BOX CULVERTS
 (DEEP FILLS)

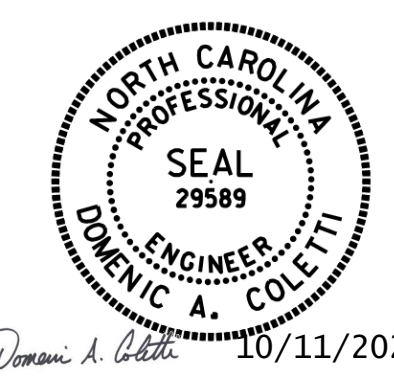

REVISIONS						SHEET NO.
NO.	BY:	DATE:	NO.	BY:	DATE:	C2-6
1			3			TOTAL SHEETS
2			4			6

DES BY: T. MCALEENAN	DATE: 11/19	DWG BY: T. MCALEENAN	DATE: 11/19
DES CHK: R. TURNAGE	DATE: 11/19	CHK BY: R. TURNAGE	DATE: 11/19

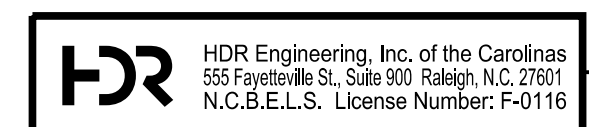

DOCUMENT NOT CONSIDERED FINAL
 UNLESS ALL SIGNATURES COMPLETED