

NOTE
SEE SHEET 1 OF 5 FOR NOTES.

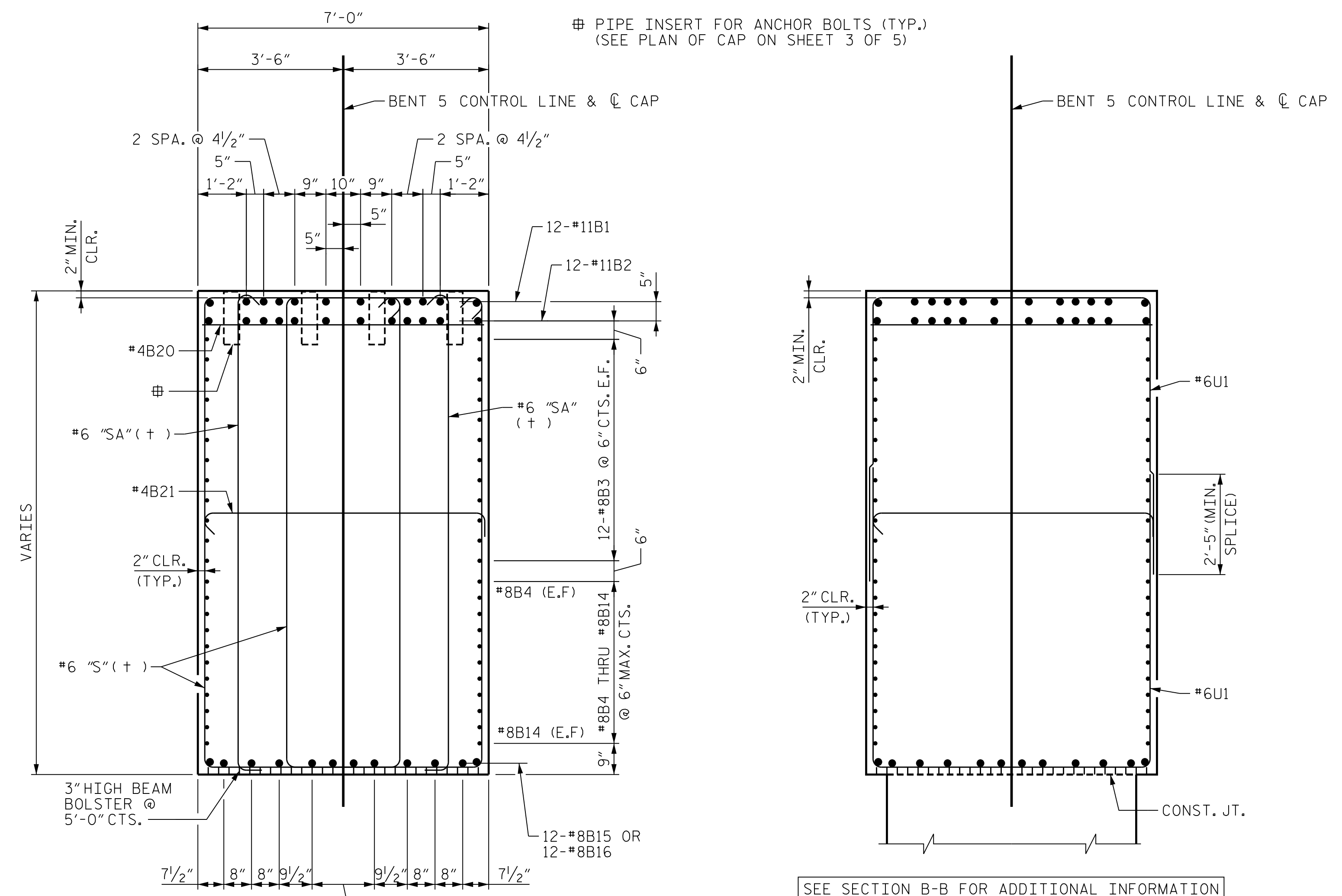

SECTION B-B
(+) SEE "STIRRUP SET DETAIL"

SEE SECTION B-B FOR ADDITIONAL INFORMATION

SECTION C-C
COLUMN REINFORCING STEEL NOT SHOWN FOR CLARITY

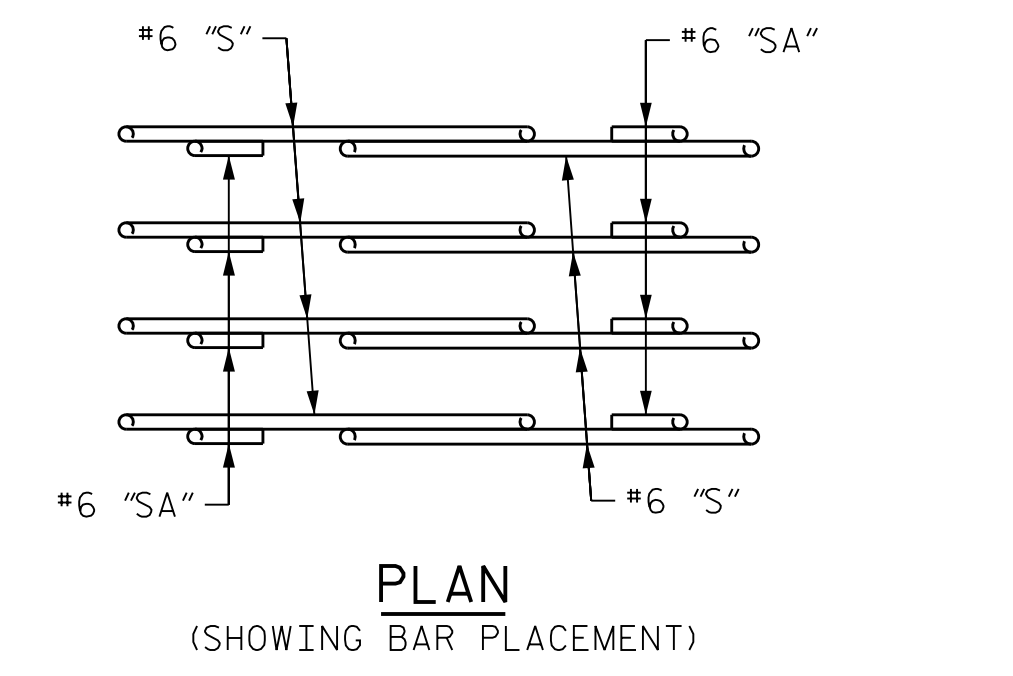

PLAN
(SHOWING BAR PLACEMENT)

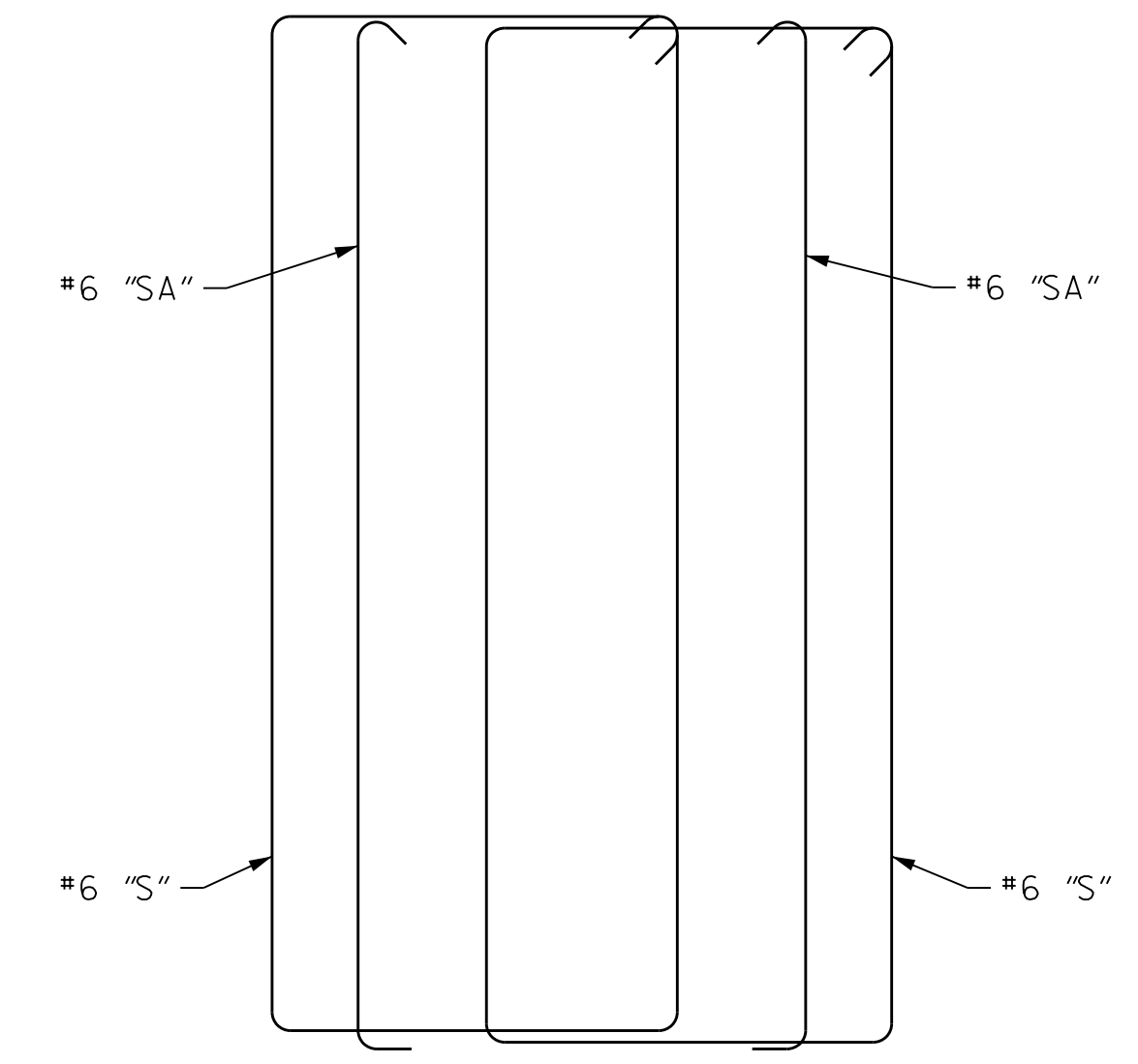

ELEVATION
(SCHEMATIC)

STIRRUP SET DETAIL

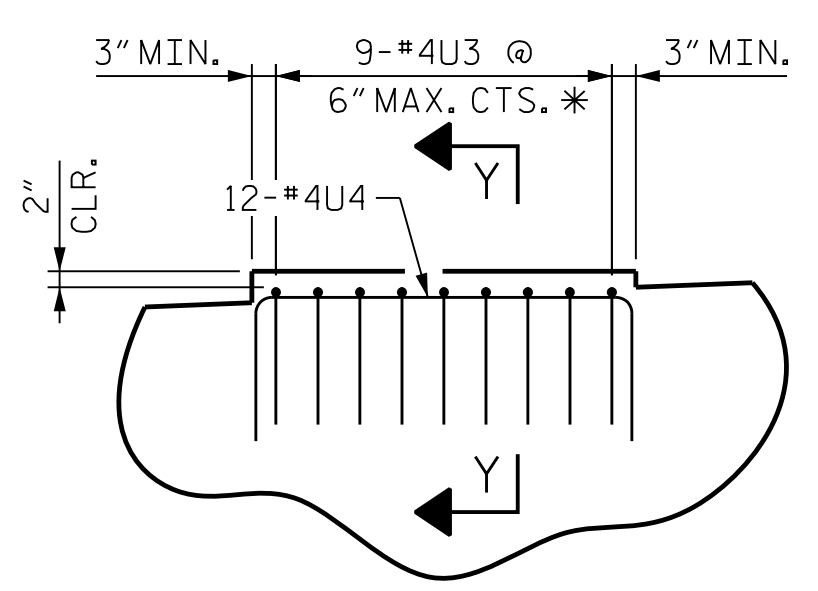

DETAIL "B"

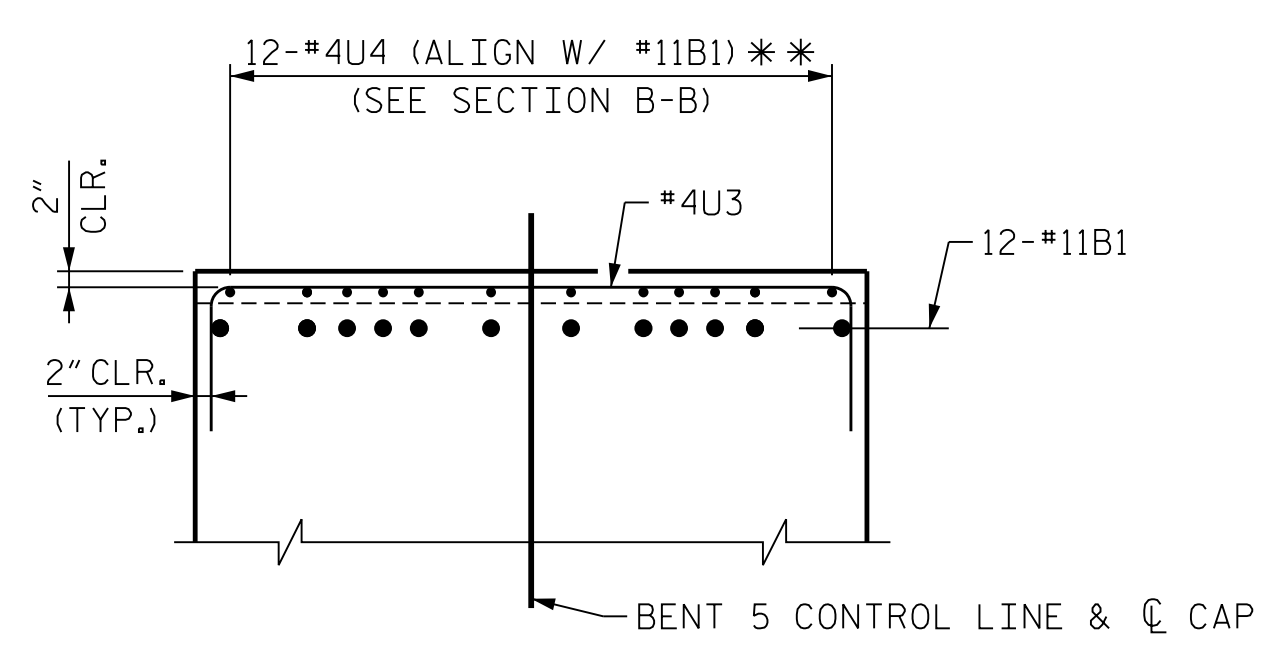

SECTION Y-Y

* NOTE:
#4U3 BARS MAY BE SHIFTED SLIGHTLY AS NECESSARY TO CLEAR PIPE INSERTS FOR ANCHOR BOLTS.
** NOTE:
#4U4 BARS MAY BE SHIFTED AS NECESSARY TO CLEAR #11B1 AND #11B2 BARS.

PROJECT NO. U-2579AB
FORSYTH COUNTY
STATION: 58+33.94 -Y15FLYCA-
SHEET 4 OF 5

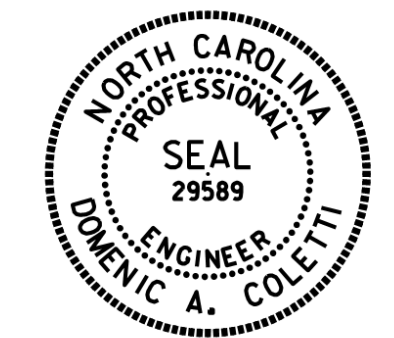

Dominic A. Coletti 10/15/2021

STATE OF NORTH CAROLINA
DEPARTMENT OF TRANSPORTATION
RALEIGH

**SUBSTRUCTURE
BENT 5
BENT CAP DETAILS**

REVISIONS						SHEET NO. 506-110 TOTAL SHEETS 129
NO.	BY:	DATE:	NO.	BY:	DATE:	
1	--	--	3	--	--	
2	--	--	4	--	--	

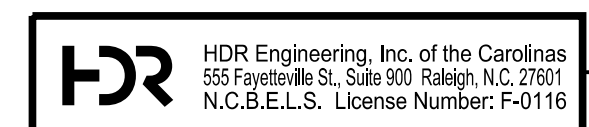

**DOCUMENT NOT CONSIDERED FINAL
UNLESS ALL SIGNATURES COMPLETED**

PLOT DRIVER: NCDOT.pdf_color_eng-50dpi
 USER: PPETERSO DATE: 10/14/2021
 TIME: 5:23:24 PM
 FILE: ...SUBSTR

DES BY: <u>K. OLIVER</u>	DATE: <u>10/19</u>	DWG BY: <u>B. PETERSON</u>	DATE: <u>12/19</u>
DES CHK: <u>M. WERNER</u>	DATE: <u>10/19</u>	CHK BY: <u>N. LIU</u>	DATE: <u>01/20</u>