

NOTE
SEE SHEET 1 OF 5 FOR NOTES.

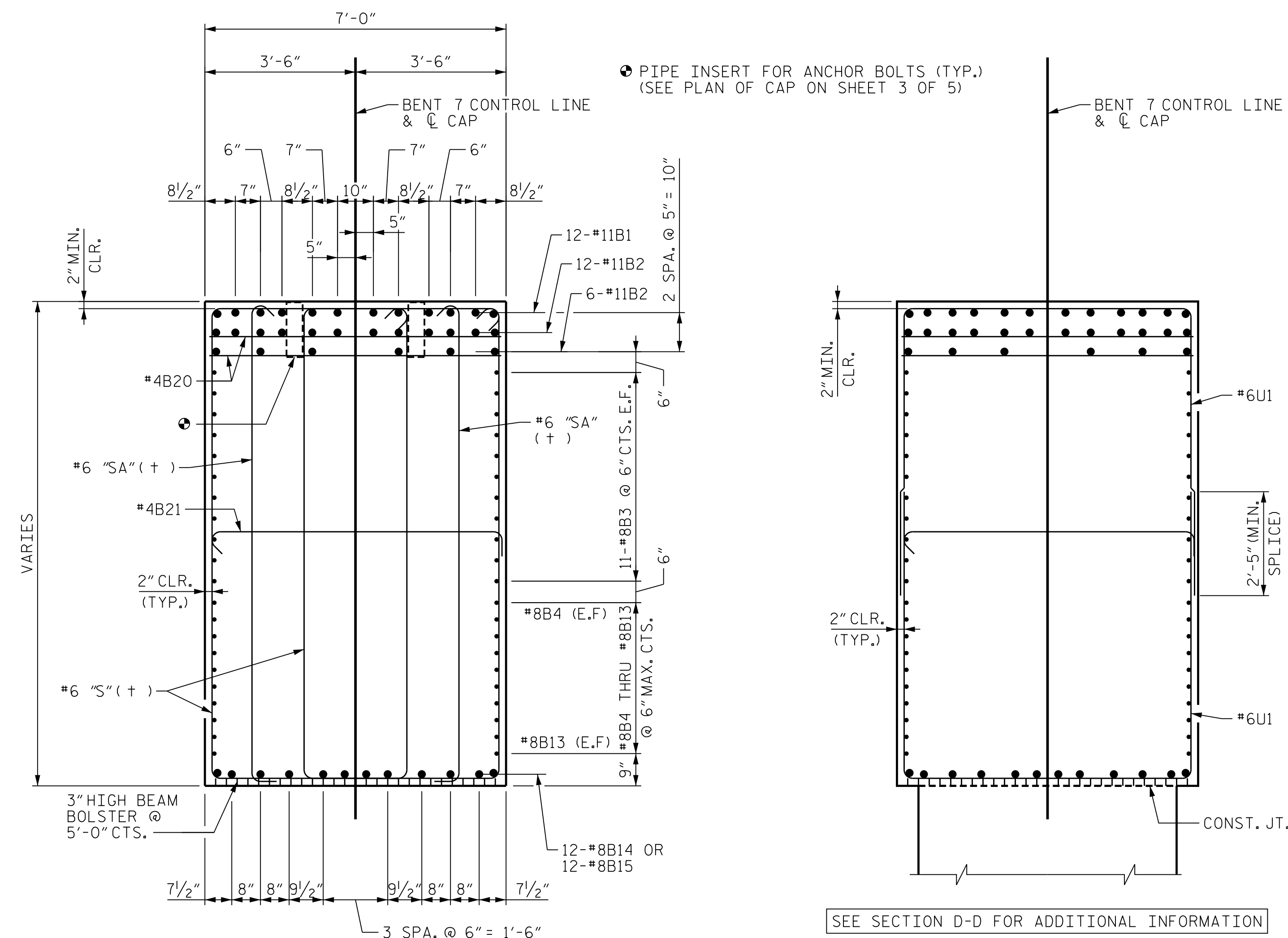

SECTION D-D
(+) SEE "STIRRUP SET DETAIL"

SEE SECTION D-D FOR ADDITIONAL INFORMATION

SECTION E-E
COLUMN REINFORCING STEEL NOT SHOWN FOR CLARITY

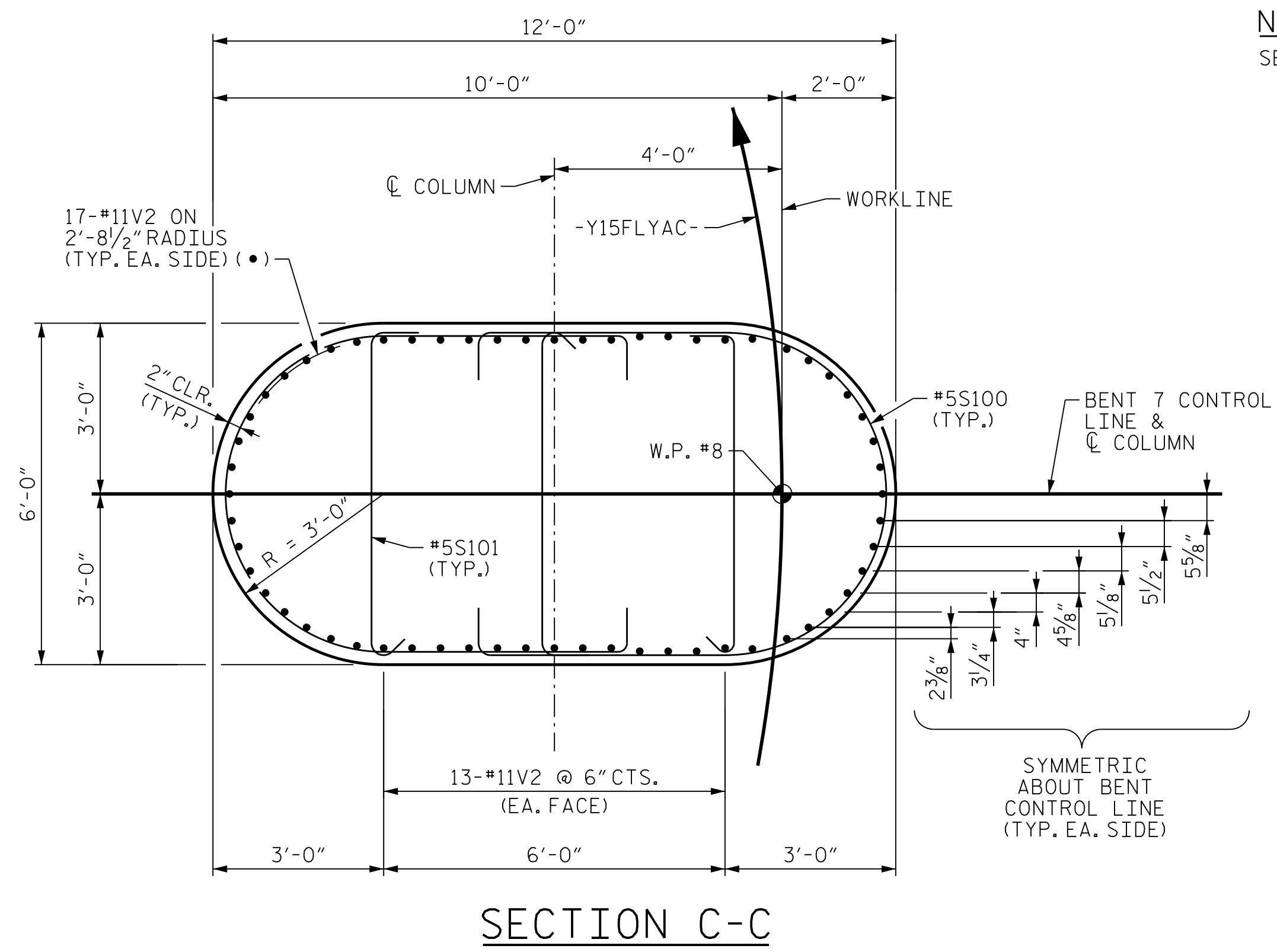

SECTION C-C

SYMMETRIC ABOUT BENT CONTROL LINE (TYP. EA. SIDE)

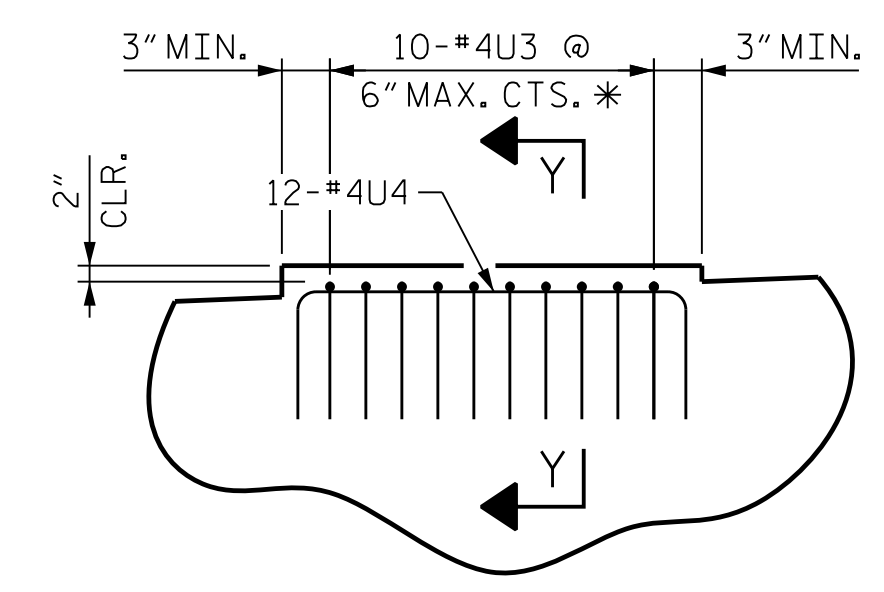

DETAIL "B"

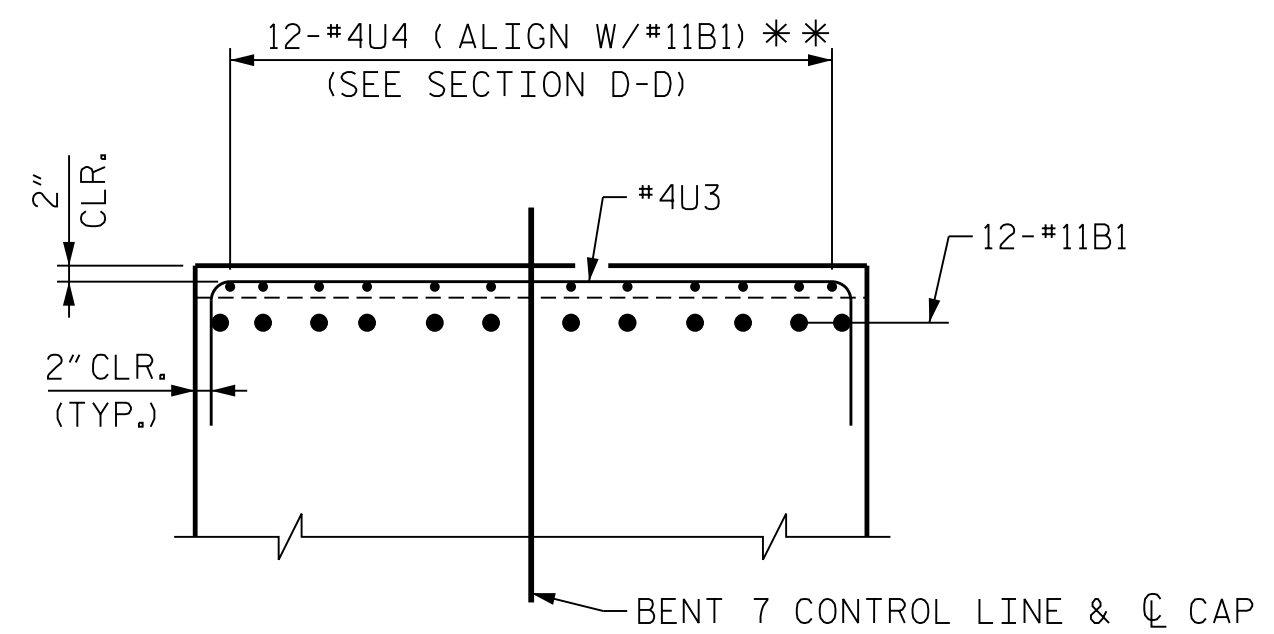

SECTION Y-Y

* NOTE:
#4U3 BARS MAY BE SHIFTED SLIGHTLY AS NECESSARY TO CLEAR PIPE INSERTS FOR ANCHOR BOLTS.
** NOTE:
#4U4 BARS MAY BE SHIFTED AS NECESSARY TO CLEAR #11B1 AND #11B2 BARS.

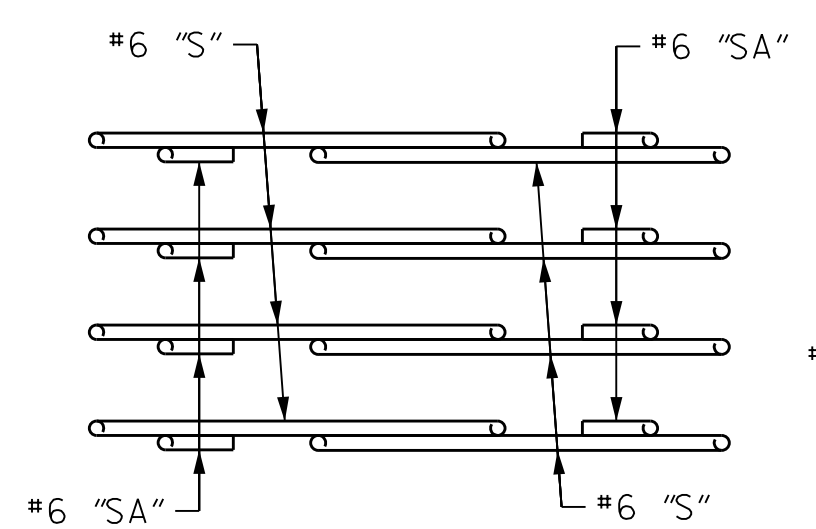

PLAN
(SHOWING BAR PLACEMENT)

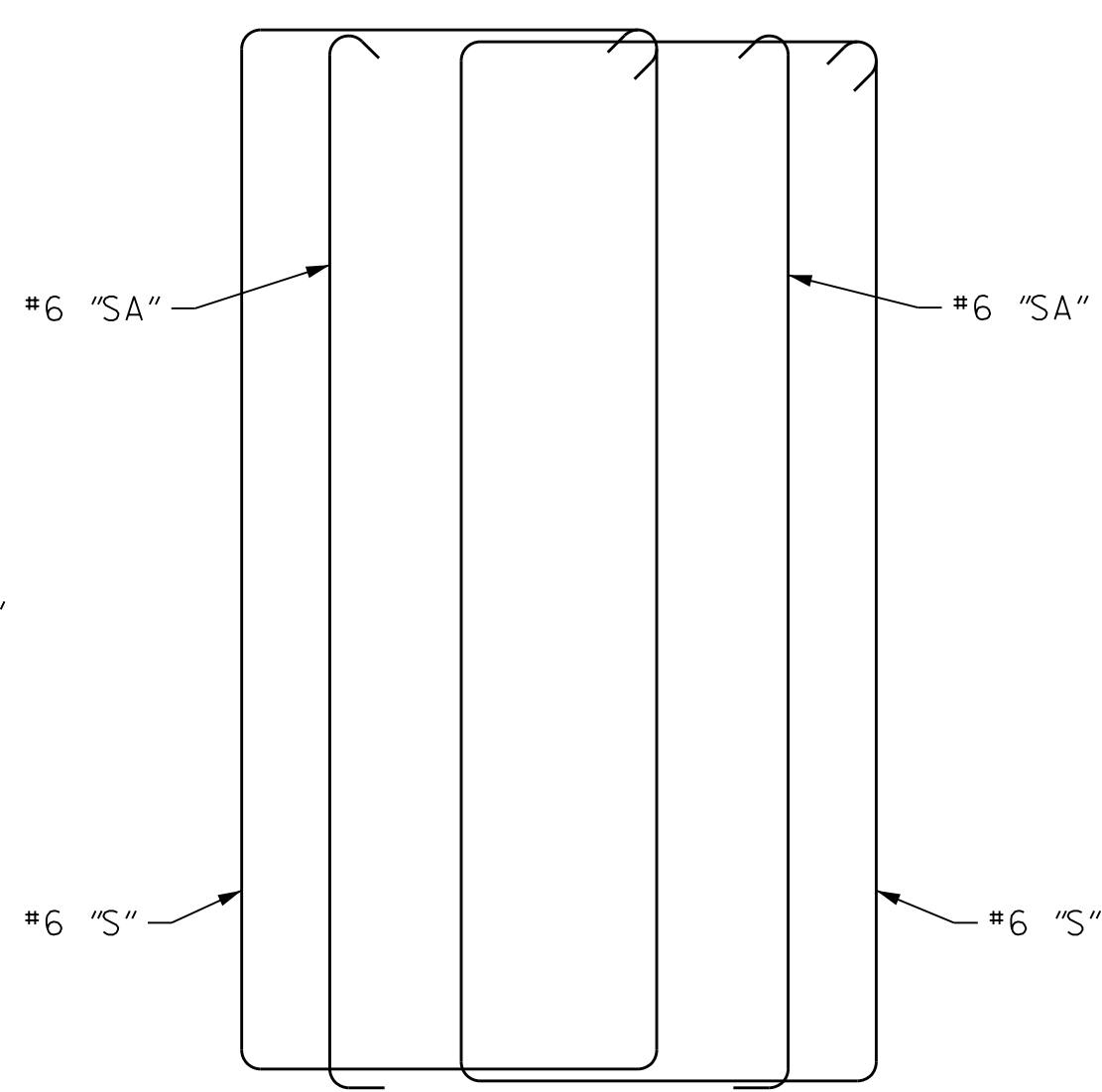

ELEVATION
(SCHEMATIC)

STIRRUP SET DETAIL

PROJECT NO. U-2579AB
FORSYTH COUNTY
STATION: 60+66.06 -Y15FLYAC-
SHEET 4 OF 5

STATE OF NORTH CAROLINA
DEPARTMENT OF TRANSPORTATION
RALEIGH

SUBSTRUCTURE BENT 7 BENT CAP DETAILS



10/15/2021

REVISIONS					
NO.	BY:	DATE:	NO.	BY:	DATE:
1	--	--	3	--	--
2	--	--	4	--	--

SHEET NO. S04-126
TOTAL SHEETS 144

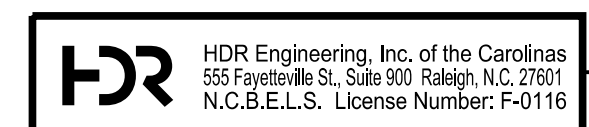

DOCUMENT NOT CONSIDERED FINAL UNLESS ALL SIGNATURES COMPLETED

PLOT DRIVER: NCDOT_pdf_color_eng-50dpi
USER: PPETERSO DATE: 10/14/2021
FILE: ...SUBSTR

DES BY: <u>K. OLIVER</u>	DATE: <u>10/19</u>	DWG BY: <u>B. PETERSON</u>	DATE: <u>10/19</u>
DES CHK: <u>M. WERNER</u>	DATE: <u>10/19</u>	CHK BY: <u>K. OLIVER</u>	DATE: <u>11/19</u>