

PLOT DRIVER: NCDOT... PENTABLE: NCDOT STRUCTURES DEFAULT PEN.tbl
USER: PPETERSO DATE: 10/14/2021 TIME: 3:57:57 PM
FILE: ... \GENERA

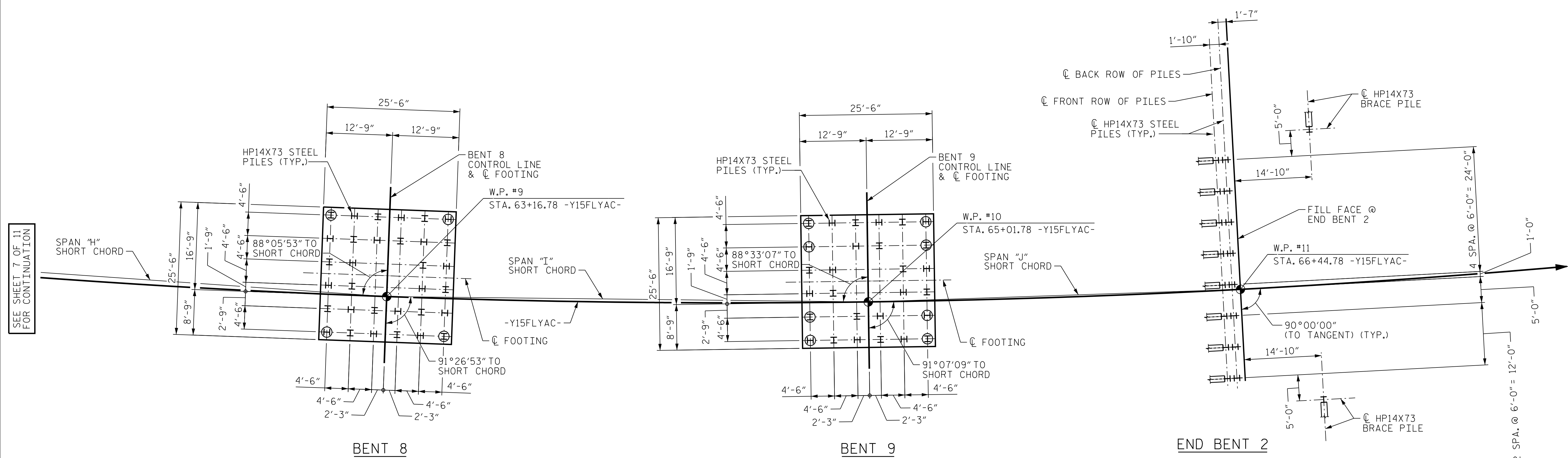

FOUNDATION LAYOUT

DIMENSIONS LOCATING PILES ARE SHOWN TO PILE CENTERLINE AT BOTTOM OF THE CAP OR FOOTING, MEASURED FROM THE TANGENT TO -Y15FLYAC- AT EACH WORK POINT.

☐ FOOTING IN THE TRANSVERSE DIRECTION IS COINCIDENT WITH THE BENT CONTROL LINE, AND RADIAL TO -Y15FLYAC-, AT ALL BENTS.

OBSERVE PILE ORIENTATION AND LOCATION OF OMITTED PILES IN EACH FOOTING.

NOTE
SEE NOTES ON SHEET 5 OF 11.

PROJECT NO. U-2579AB
FORSYTH COUNTY
 STATION: 60+66.06 -Y15FLYAC-
 SHEET 8 OF 11

- LEGEND**
- ⊥ HP14X73 VERTICAL PILE
 - ⊥--- HP14X73 BRACE PILE (BATTER 3H:12V)
 - ⊕ HP14X73 TENSION PILE



Dominic A. Coletti 10/15/2021

DES BY: J. CABABE	DATE: 10/19	DWG BY: D. CARTER	DATE: 11/19
DES CHK: S. CHAUDHARI	DATE: 10/19	CHK BY: M. WERNER	DATE: 12/19

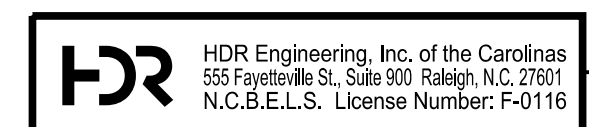

DOCUMENT NOT CONSIDERED FINAL UNLESS ALL SIGNATURES COMPLETED

REVISIONS						SHEET NO. 144	
NO.	BY:	DATE:	NO.	BY:	DATE:	TOTAL SHEETS	
1	--	--	3	--	--	144	
2	--	--	4	--	--	144	