

**DOCUMENT NOT CONSIDERED FINAL UNLESS ALL SIGNATURES COMPLETED**

**HDR** HDR Engineering, Inc. of the Carolinas  
555 Fayetteville St. Suite 900 Raleigh, N.C. 27601  
N.C.B.E.L.S. License Number: F-0116

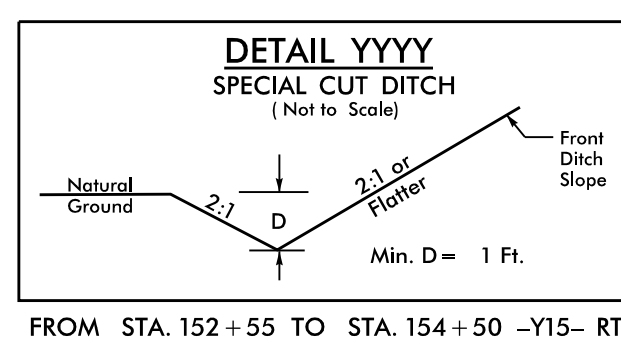
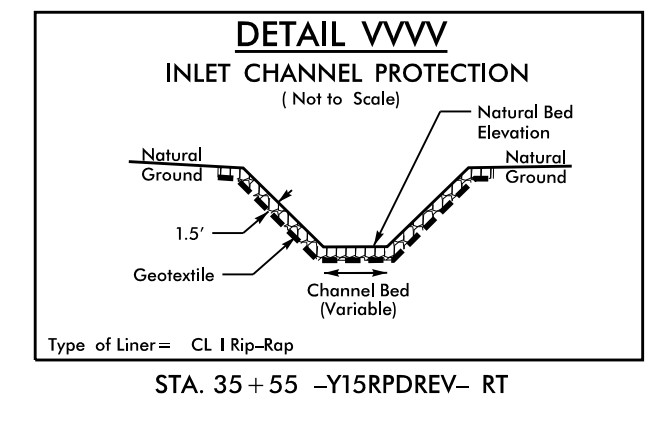
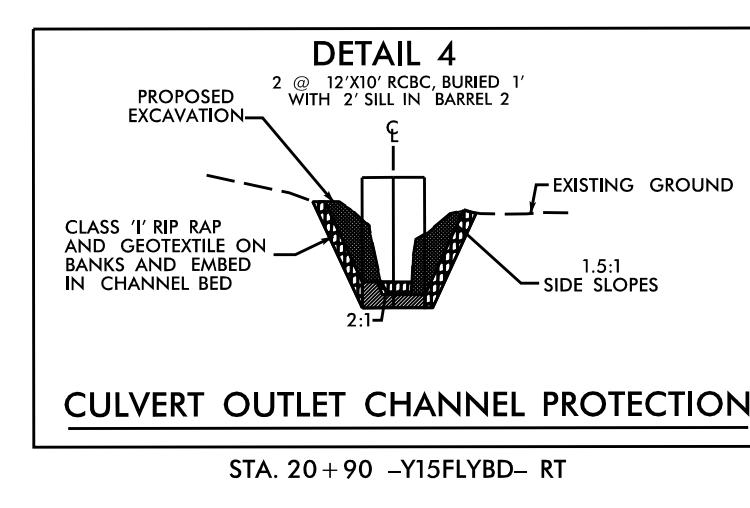
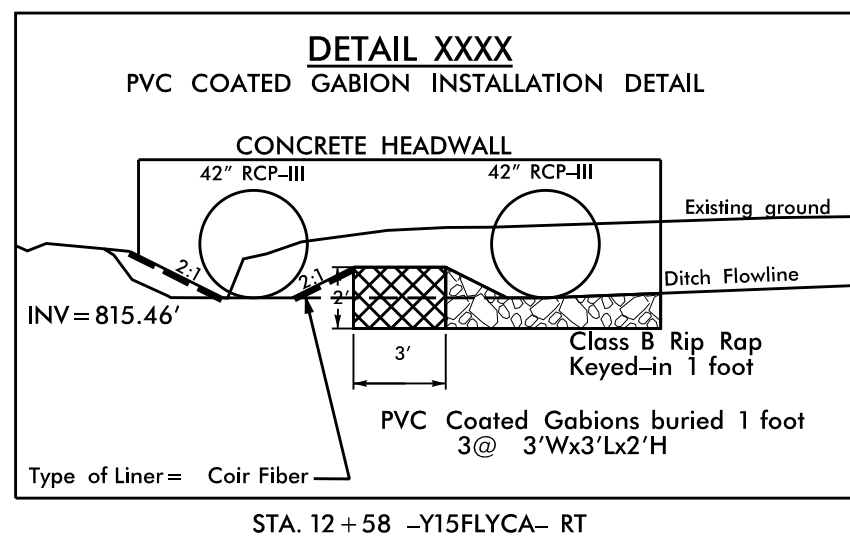
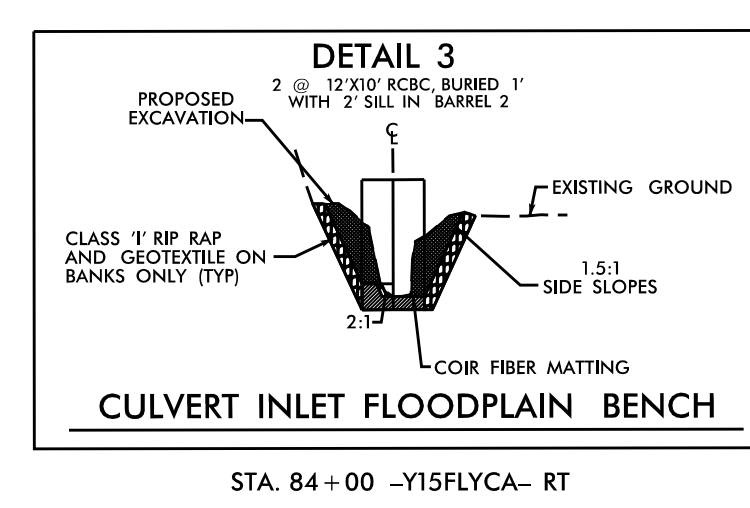
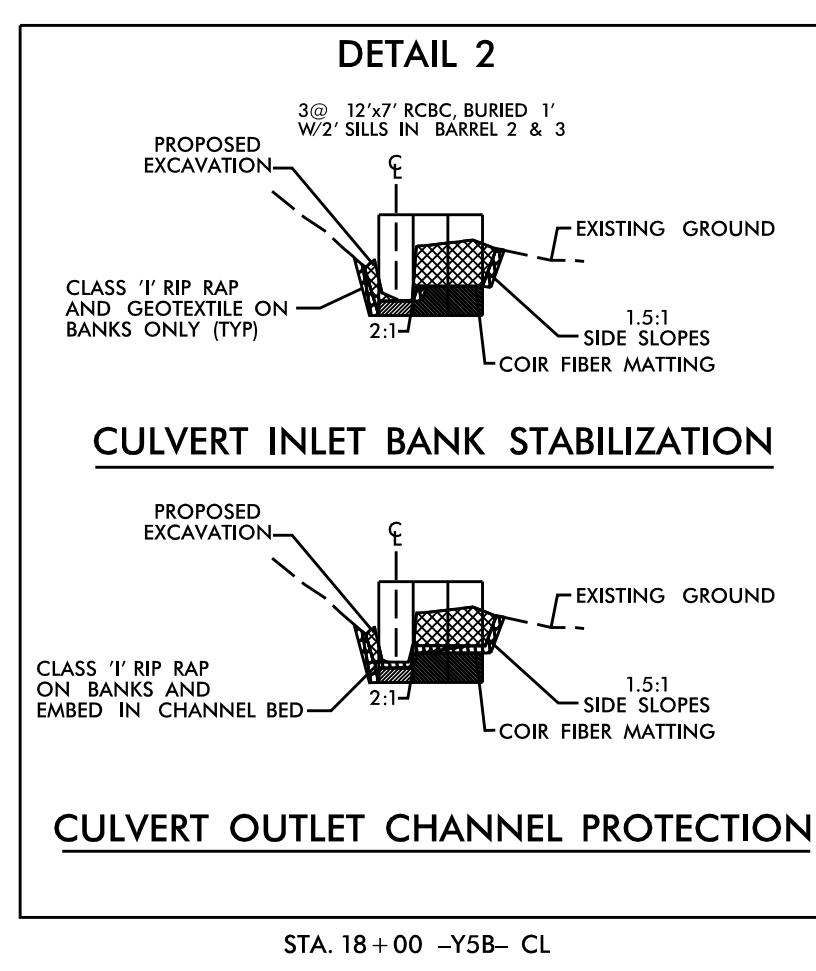
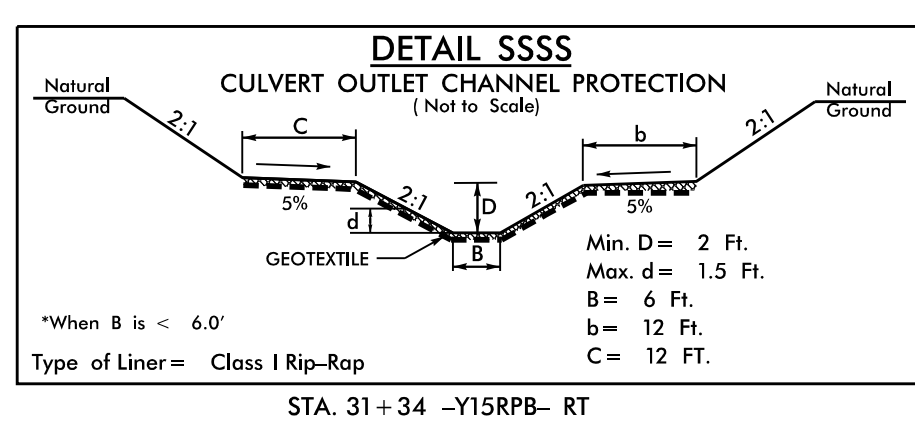
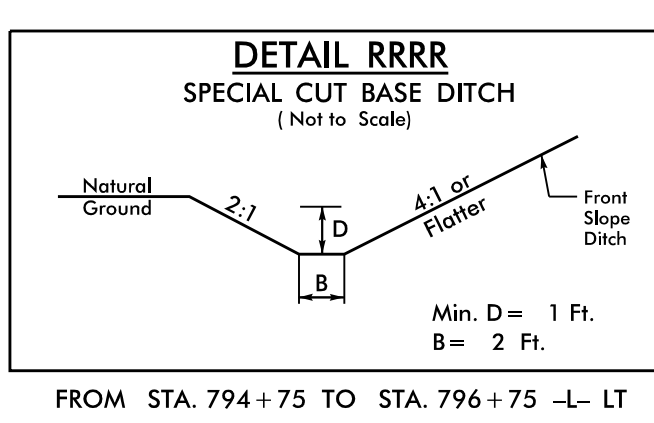
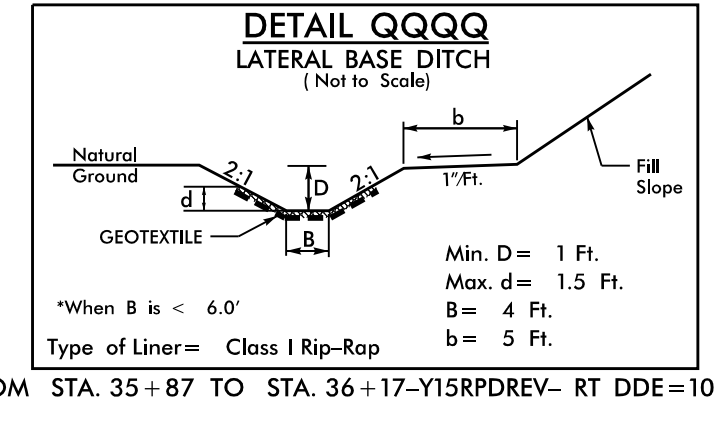
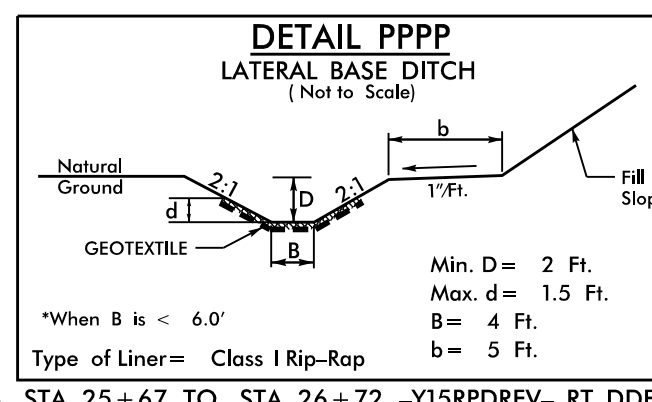
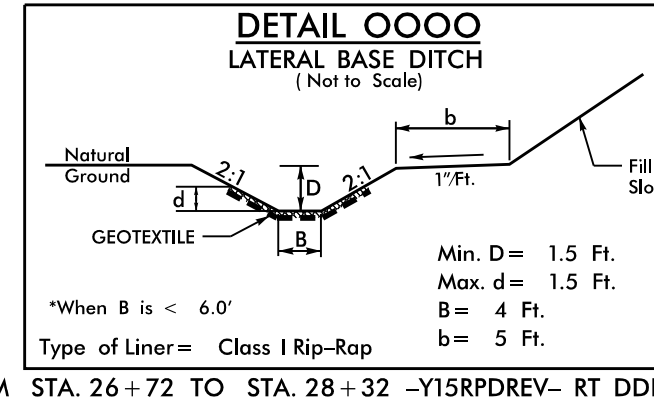
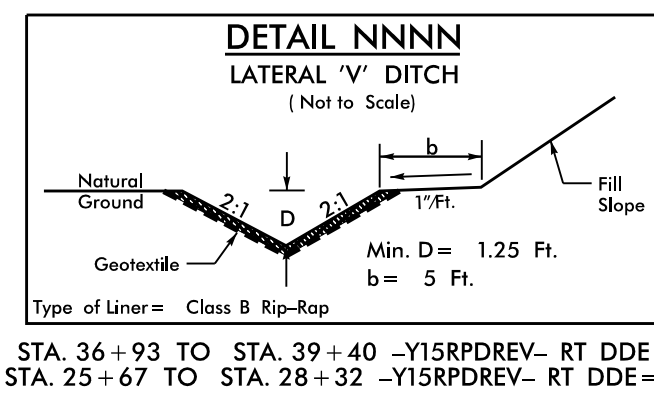
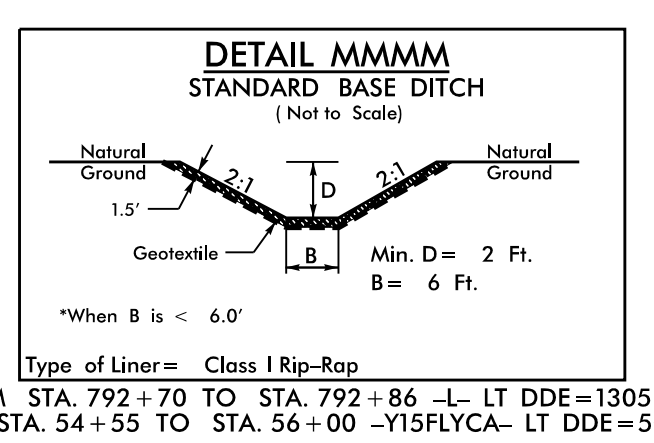
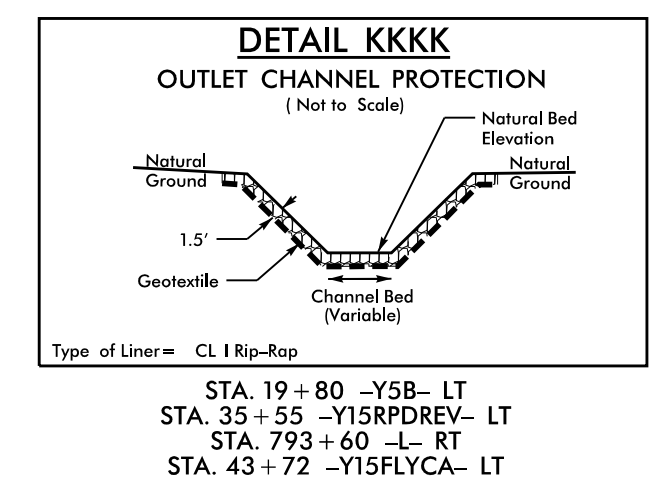
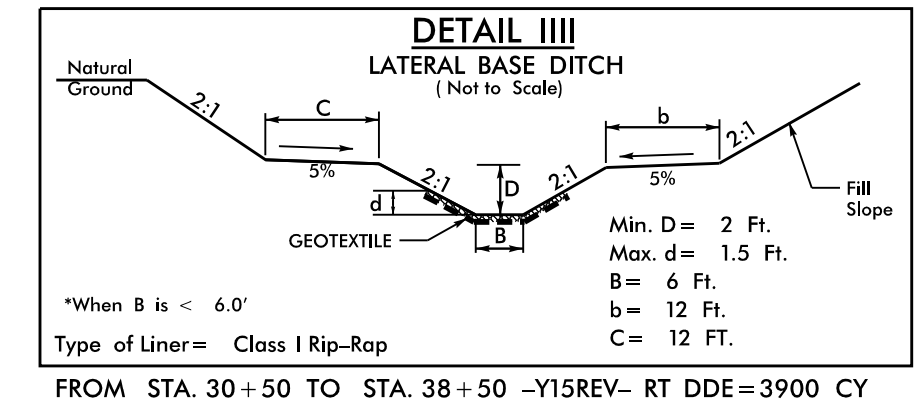
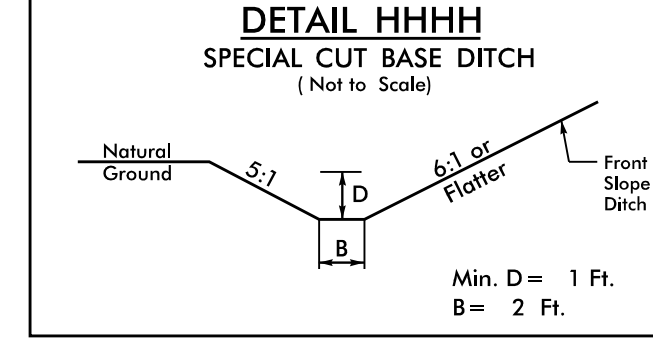
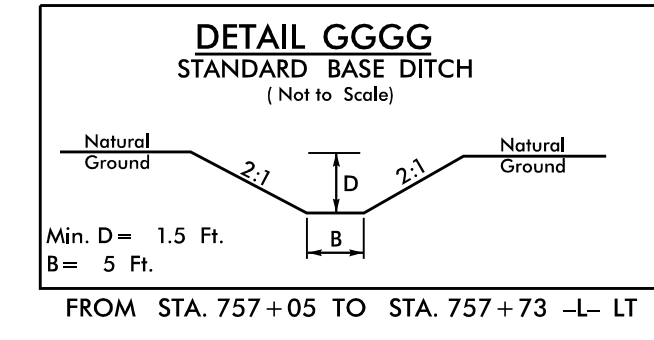
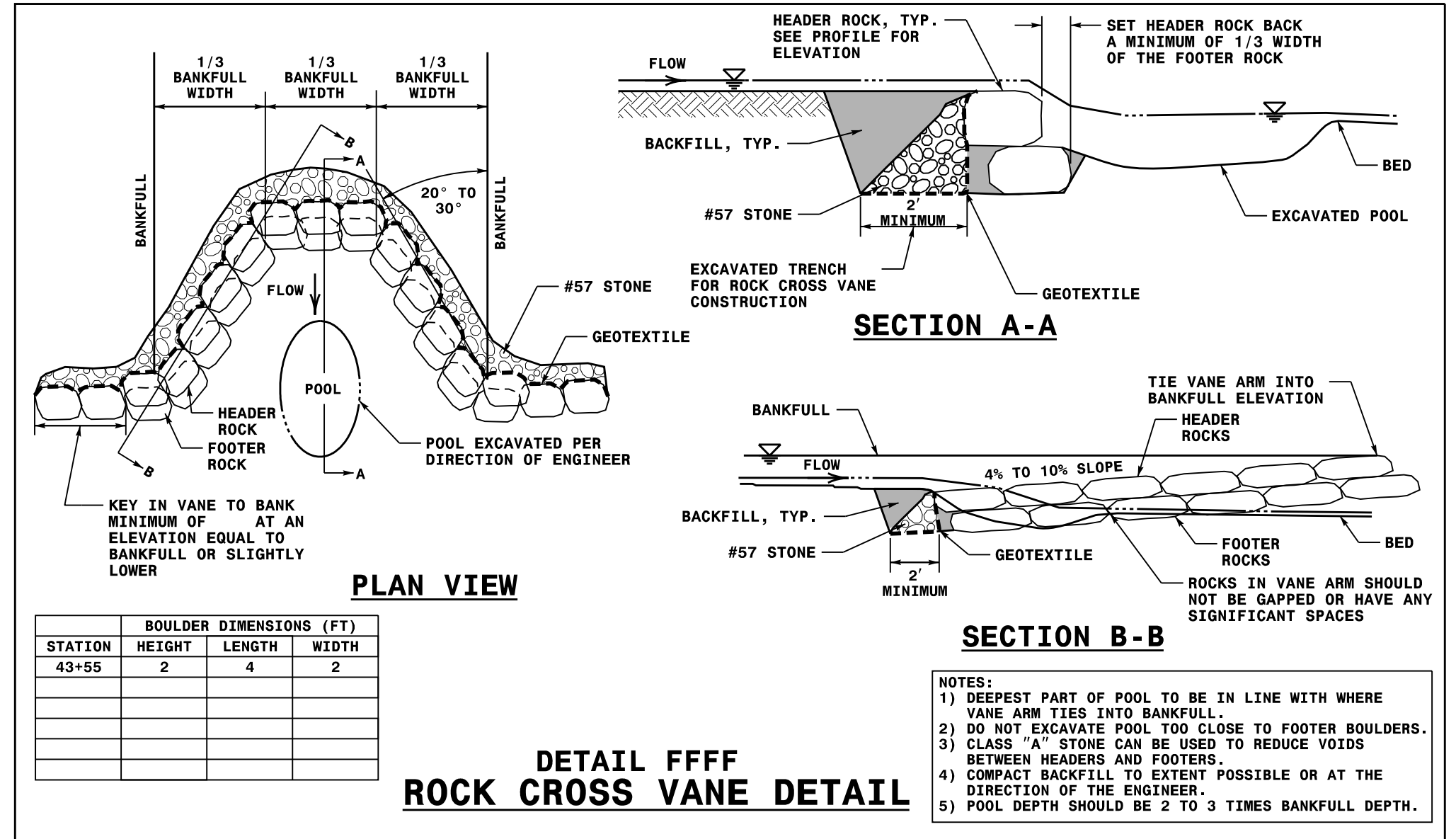
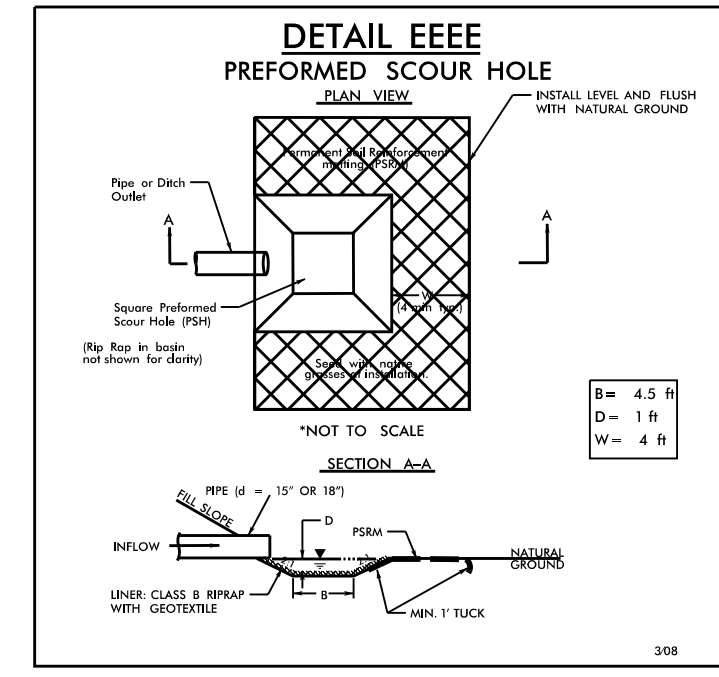
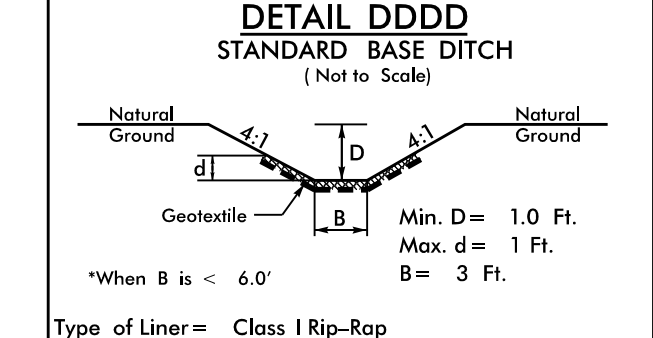
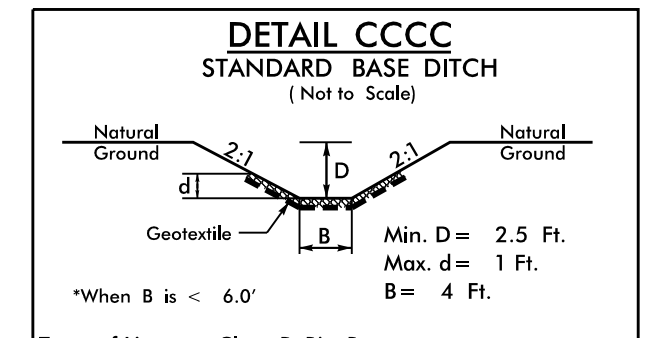
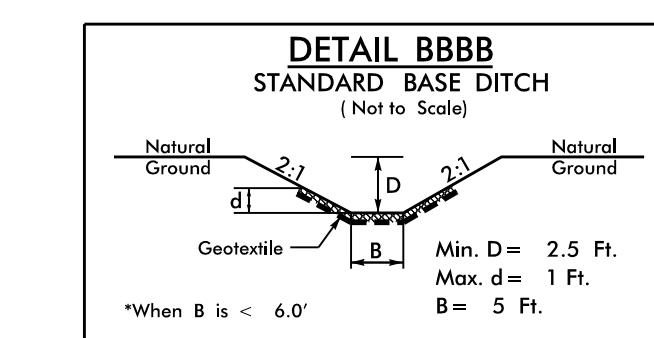
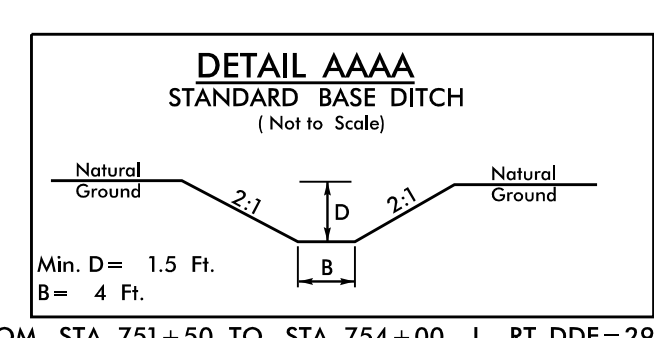
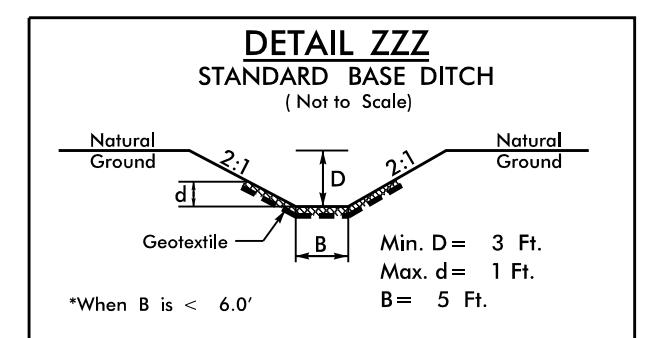
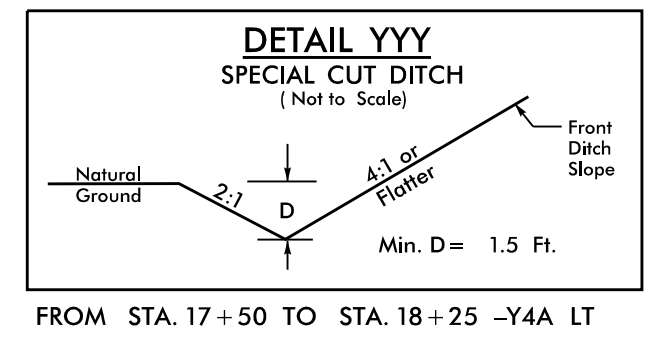

REVISIONS

PLOT DRIVER: NCDOT\_pdf\_color\_eng\_50.plt  
USER: CHARRIS  
FILE: NCDOT\NCDOT-U2579AB\6.0.CAD.BTM\6.2.Work\In\_Progress\U-2579AB\Hydr\culves\CADD\U2579AB\_HYD\_DETAIL

PENTABLE: NCDOT\_pshp\_fl\_conventional.tbl  
DATE: 7/13/2021  
TIME: 12:48:14 PM