

STATE OF NORTH CAROLINA
DIVISION OF HIGHWAYS

TRANSPORTATION MANAGEMENT PLAN

DARE COUNTY

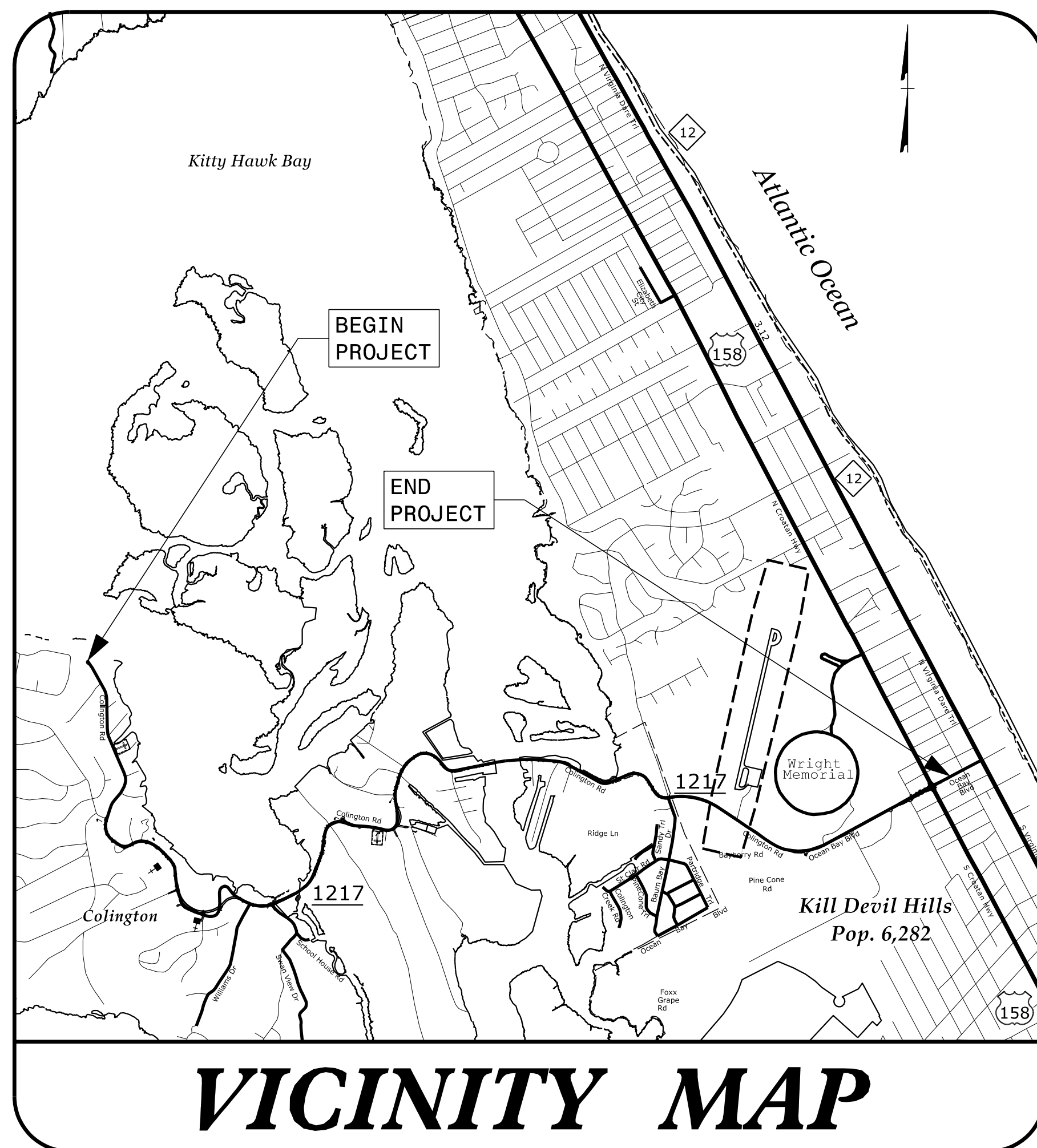
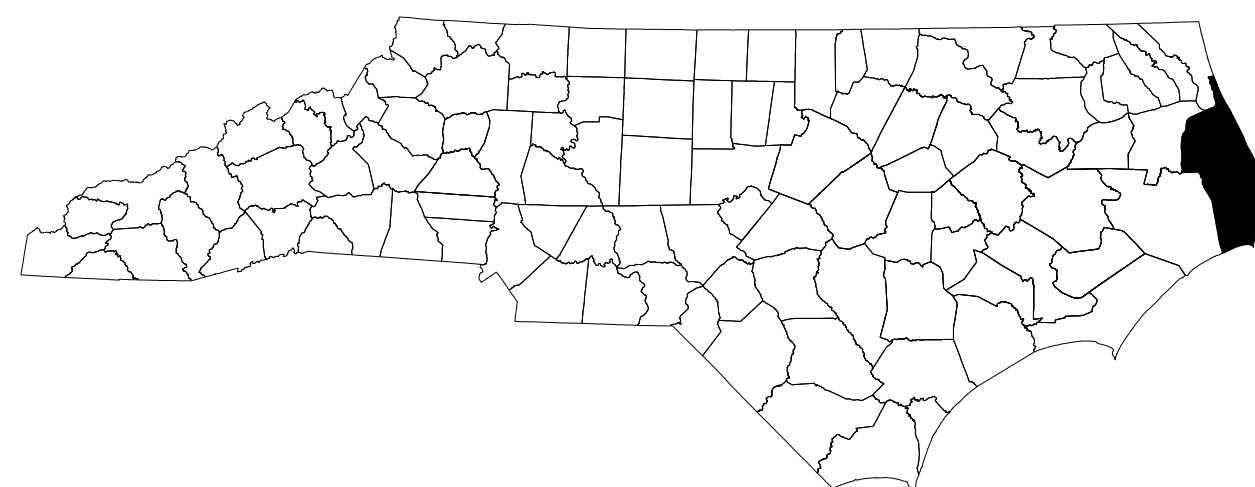

**LOCATION: SR 1217 (COLINGTON RD.) FROM DEAD
END TO US 158 CROATAN HIGHWAY IN
KILL DEVIL HILLS**

**TYPE OF WORK: GRADING, DRAINAGE, PAVING
AND RESURFACING**

VICINITY MAP

INDEX OF SHEETS

SHEET NO.	TITLE
TMP-1	TITLE SHEET, VICINITY MAP, AND INDEX OF SHEETS
TMP-1A	LIST OF APPLICABLE ROADWAY STANDARD DRAWINGS AND LEGEND
TMP-1B THRU 1C	TRANSPORTATION OPERATIONS PLAN: (MANAGEMENT STRATEGIES AND GENERAL NOTES)
TMP-2	TEMPORARY SHORING DATA
TMP-3	TEMPORARY TRAFFIC CONTROL PHASING
TMP-4	TEMPORARY SHORING DETAIL -WALL1- & -WALL2-
TMP-5	ON-SITE DETOUR FOR OPEN-CUT PIPE INSTALLATION

SHEET NO.
TMP-1

R-5014

TIP PROJECT:

**DOCUMENT NOT CONSIDERED FINAL
UNLESS ALL SIGNATURES COMPLETED**

APPROVED: *David W. Bisette*
DATE: 4/29/2021



PLANS PREPARED FOR THE NCDOT BY:
M MOTT MACDONALD & E, LLC
1101 HAYNES STREET, SUITE 101
RALEIGH, NC 27604
NC LICENSE NO. F-0669

SEAL

PLANS PREPARED BY:

D W BISSETTE

NCDOT CONTACTS:

D A PARKER
PROJECT ENGINEER

S B JENNINGS
PROJECT DESIGN ENGINEER

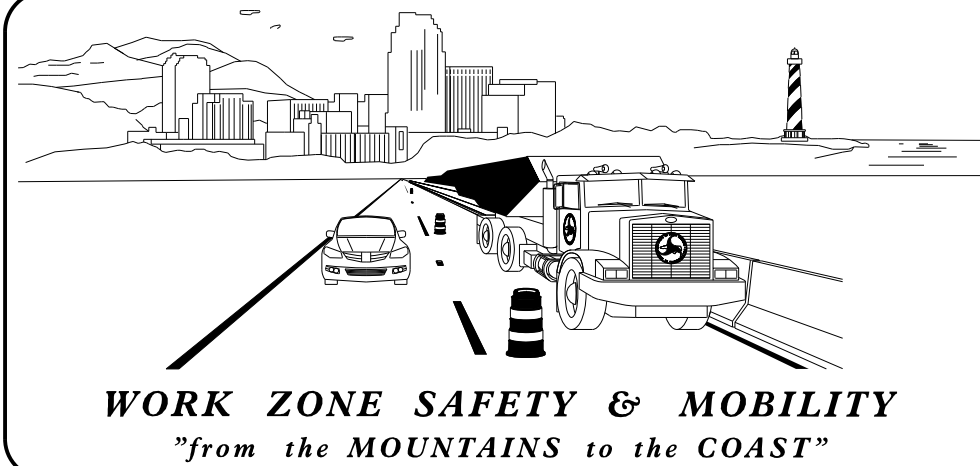
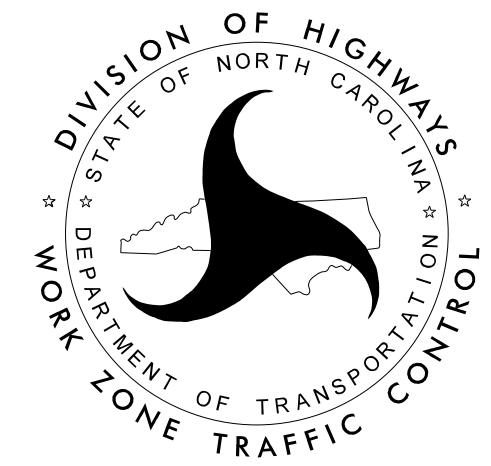

4/28/2021
\\USFUDUHVH\FPS01\Proj\396782_Calyx_R-5014\TrafficControl\TCP\R-5014_TC_TMP_0.dgn
User: HBY93356

ROADWAY STANDARD DRAWINGS

THE FOLLOWING ROADWAY STANDARDS AS SHOWN IN "ROADWAY STANDARD DRAWINGS" - N.C. DEPARTMENT OF TRANSPORTATION - RALEIGH, N.C., DATED JANUARY 2018 ARE APPLICABLE TO THIS PROJECT AND BY REFERENCE HEREBY ARE CONSIDERED A PART OF THESE PLANS:

STD. NO.	TITLE
1101.01	WORK ZONE ADVANCE WARNING SIGNS
1101.02	TEMPORARY LANE CLOSURES
1101.04	TEMPORARY SHOULDER CLOSURES
1101.05	WORK ZONE VEHICLE ACCESSES
1101.11	TRAFFIC CONTROL DESIGN TABLES
1110.01	STATIONARY WORK ZONE SIGNS
1110.02	PORTABLE WORK ZONE SIGNS
1115.01	FLASHING ARROW BOARDS
1130.01	DRUM
1135.01	CONES
1145.01	BARRICADES
1150.01	FLAGGING DEVICES
1160.01	TEMPORARY CRASH CUSHION
1165.01	WORK VEHICLE LIGHTING SYSTEMS AND TMA DELINEATION
1170.01	POSITIVE PROTECTION
1180.01	SKINNY-DRUM
1205.01	PAVEMENT MARKINGS - LINE TYPES AND OFFSETS
1205.02	PAVEMENT MARKINGS - TWO-LANE AND MULTI-LANE ROADWAYS
1205.04	PAVEMENT MARKINGS - INTERSECTIONS
1205.05	PAVEMENT MARKINGS - TURN LANES
1205.07	PAVEMENT MARKINGS - PEDESTRIAN CROSSWALKS
1205.08	PAVEMENT MARKINGS - SYMBOLS AND WORD MESSAGES
1205.09	PAVEMENT MARKINGS - PAINTED ISLANDS
1205.10	PAVEMENT MARKINGS - SCHOOL AREAS
1205.12	PAVEMENT MARKINGS - BRIDGES
1250.01	RAISED PAVEMENT MARKERS - INSTALLATION SPACING
1251.01	RAISED PAVEMENT MARKERS - PERMANENT AND TEMPORARY
1261.01	GUARDRAIL AND BARRIER DELINEATORS - INSTALLATION SPACING
1261.02	GUARDRAIL AND BARRIER DELINEATORS - TYPES AND MOUNTING
1262.01	GUARDRAIL END DELINEATION
1264.01	OBJECT MARKERS - TYPES
1264.02	OBJECT MARKERS - INSTALLATION

LEGEND

GENERAL

- DIRECTION OF TRAFFIC FLOW
- DIRECTION OF PEDESTRIAN TRAFFIC FLOW
- EXIST. PVMT.
- NORTH ARROW
- PROPOSED PVMT.
- TEMP. SHORING (LOCATION PURPOSES ONLY)

- WORK AREA
- REMOVAL
- INCIDENTAL STONE
- USER DEFINED (IF NEEDED)

SIGNALS

- EXISTING
- PROPOSED
- TEMPORARY

PAVEMENT MARKINGS

- EXISTING LINES
- TEMPORARY LINES

TRAFFIC CONTROL DEVICES

- BARRICADE (TYPE III)
- CONE
- DRUM
- SKINNY DRUM
- TUBULAR MARKER
- TEMPORARY CRASH CUSHION
- FLASHING ARROW BOARD
- FLAGGER
- LAW ENFORCEMENT
- TRUCK MOUNTED ATTENUATOR (TMA)
- CHANGEABLE MESSAGE SIGN

TEMPORARY SIGNING

- PORTABLE SIGN
- STATIONARY SIGN
- STATIONARY OR PORTABLE SIGN

PAVEMENT MARKERS

- CRYSTAL/CRYSTAL
- CRYSTAL/RED
- YELLOW/YELLOW

PAVEMENT MARKING SYMBOLS

- PAVEMENT MARKING SYMBOLS

TEMPORARY PAVEMENT MARKING

- | | |
|------------------------------------|--------------------------------|
| <u>PAINT (24")</u> | <u>PAINTMARKING CHARACTERS</u> |
| P2 WHITE STOPBAR | QI ALPHANUMERIC CHAR. |
| P3 WHITE CROSSWALK LINE | |
| <u>PAINT (4")</u> | <u>PAINTMARKING SYMBOLS</u> |
| P8 WHITE 2 FT. - 6 FT./SP MINISKIP | QA LEFT TURN ARROW |
| PA WHITE EDGELINE | QB RIGHT TURN ARROW |
| PC 10 FT. WHITE SKIP | QC STRAIGHT ARROW |
| PD 3 FT. - 9 FT./SP WHITE MINISKIP | QD COMBO. STRAIGHT/LEFT |
| PE WHITE SOLID LANE LINE | QE COMBO. STRAIGHT/RIGHT |
| PF 10 FT. YELLOW SKIP | |
| PH YELLOW SINGLE CENTER | |
| PI YELLOW DOUBLE CENTER | |
| <u>PAINT (8")</u> | |
| PP YELLOW DIAGONAL | |

4/28/2021
 \\USFUDUHVFFS01\Proj\396782_Calyx_R-5014\TrafficControl\TCP\R-5014_TC_TMP_01a.dgn
 User:BOY89356

APPROVED: DATE: 4/29/2021 SEAL		
ROADWAY STANDARD DRAWINGS & LEGEND		
DOCUMENT NOT CONSIDERED FINAL UNLESS ALL SIGNATURES COMPLETED		

MANAGEMENT STRATEGIES

USING TEMPORARY LANE CLOSURES AND FLAGGERS:
 -CONSTRUCT THE PROPOSED WIDENING UP TO THE EXISTING EDGE AND ELEVATION
 -CONSTRUCT THE PROPOSED FULL DEPTH SECTIONS. USE TEMPORARY WEDGING AS NEEDED TO MAINTAIN TRAFFIC ON THE EXISTING ALIGNMENT
 -CONSTRUCT TEMPORARY PAVEMENT AND INSTALL PORTABLE BARRIER ON -Y3C-

WORKING BEHIND PORTABLE BARRIER ON -Y3C-:
 -INSTALL SHORING
 -REMOVE THE EXISTING HEADWALL
 -COLLAR AND EXTEND THE EXISTING PIPE
 -CONSTRUCT PROPOSED WALLS

USING TEMPORARY LANE CLOSURES AND FLAGGERS:
 -REMOVE SHORING ON -Y3C-
 -REMOVE PORTABLE BARRIER ON -Y3C-
 -PLACE TEMPORARY MARKINGS AND SHIFT TRAFFIC TO THE FINAL PATTERN
 -CONSTRUCT PROPOSED MONOLITHIC ISLAND
 -PLACE THE FINAL LAYER OF SURFACE COURSE
 -PLACE THE FINAL PAVEMENT MARKINGS AND PAVEMENT MARKERS
 -REMOVE ALL TRAFFIC CONTROL DEVICES

GENERAL NOTES

CHANGES MAY BE REQUIRED WHEN PHYSICAL DIMENSIONS IN THE DETAIL DRAWINGS, STANDARD DETAILS, AND ROADWAY DETAILS ARE NOT ATTAINABLE TO MEET FIELD CONDITIONS OR RESULT IN DUPLICATE OR UNDESIRED OVERLAPPING OF DEVICES. MODIFICATION MAY INCLUDE: MOVING, SUPPLEMENTING, COVERING, OR REMOVAL OF DEVICES AS DIRECTED BY THE ENGINEER.

THE FOLLOWING GENERAL NOTES APPLY AT ALL TIMES FOR THE DURATION OF THE CONSTRUCTION PROJECT EXCEPT WHEN OTHERWISE NOTED IN THE PLAN OR DIRECTED BY THE ENGINEER.

TIME RESTRICTIONS

- A) DO NOT CLOSE OR NARROW TRAVEL LANES AS FOLLOWS:
- | ROAD NAME | DAY AND TIME RESTRICTIONS |
|-----------|--|
| ALL ROADS | MONDAY THROUGH FRIDAY
6:00 AM TO 9:00 AM AND 4:00 PM TO 7:00 PM
AND FRIDAY 7:00 PM TO MONDAY 6:00 AM |
- B) DO NOT CLOSE OR NARROW TRAVEL LANES DURING HOLIDAYS AND SPECIAL EVENTS AS FOLLOWS:
- | ROAD NAME | HOLIDAY |
|-----------|--|
| ALL ROADS | <ol style="list-style-type: none"> FOR ANY UNEXPECTED OCCURRENCE THAT CREATES UNUSUALLY HIGH TRAFFIC VOLUMES, AS DIRECTED BY THE ENGINEER. FOR NEW YEAR'S, BETWEEN THE HOURS OF 6:00 AM DECEMBER 31st AND 7:00 PM JANUARY 2ND. IF NEW YEAR'S DAY IS ON A FRIDAY, SATURDAY, SUNDAY, OR MONDAY THEN UNTIL 7:00 PM THE FOLLOWING TUESDAY. |

- FOR EASTER, BETWEEN THE HOURS OF 6:00AM THURSDAY AND 7:00 PM MONDAY.
- FOR MEMORIAL DAY, BETWEEN THE HOURS OF 6:00 AM FRIDAY AND 7:00 PM TUESDAY.
- FOR INDEPENDENCE DAY, BETWEEN THE HOURS OF 6:00 AM THE DAY BEFORE INDEPENDENCE DAY AND 8:00 PM THE DAY AFTER INDEPENDENCE DAY.

IF INDEPENDENCE DAY IS ON A FRIDAY, SATURDAY, SUNDAY OR MONDAY THEN BETWEEN THE HOURS OF 6:00 AM THE THURSDAY BEFORE INDEPENDENCE DAY AND 8:00 PM THE TUESDAY AFTER INDEPENDENCE DAY.
- FOR LABOR DAY, BETWEEN THE HOURS OF 6:00 AM FRIDAY AND 8:00 PM TUESDAY.
- FOR THANKSGIVING DAY, BETWEEN THE HOURS OF 6:00 AM TUESDAY TO 7:00 PM MONDAY.
- FOR CHRISTMAS, BETWEEN THE HOURS OF 6:00 AM THE FRIDAY BEFORE THE WEEK OF CHRISTMAS DAY AND 7:00 PM THE FOLLOWING TUESDAY AFTER THE WEEK OF CHRISTMAS.

LANE AND SHOULDER CLOSURE REQUIREMENTS

- REMOVE LANE CLOSURE DEVICES FROM THE LANE WHEN WORK IS NOT BEING PERFORMED BEHIND THE LANE CLOSURE OR WHEN A LANE CLOSURE IS NO LONGER NEEDED OR AS DIRECTED BY THE ENGINEER.
- WHEN PERSONNEL AND/OR EQUIPMENT ARE WORKING WITHIN 15 FT OF AN OPEN TRAVEL LANE, CLOSE THE NEAREST OPEN SHOULDER USING ROADWAY STANDARD DRAWING NO. 1101.04 UNLESS THE WORK AREA IS PROTECTED BY BARRIER OR GUARDRAIL OR A LANE CLOSURE IS INSTALLED.
- WHEN PERSONNEL AND/OR EQUIPMENT ARE WORKING ON THE SHOULDER ADJACENT TO AN UNDIVIDED FACILITY AND WITHIN 5 FT OF AN OPEN TRAVEL LANE, CLOSE THE NEAREST OPEN TRAVEL LANE USING ROADWAY STANDARD DRAWING NO. 1101.02 UNLESS THE WORK AREA IS PROTECTED BY BARRIER OR GUARDRAIL.

WHEN PERSONNEL AND/OR EQUIPMENT ARE WORKING ON THE SHOULDER ADJACENT TO A DIVIDED FACILITY AND WITHIN 10 FT OF AN OPEN TRAVEL LANE, CLOSE THE NEAREST OPEN TRAVEL LANE USING ROADWAY STANDARD DRAWING NO. 1101.02 UNLESS THE WORK AREA IS PROTECTED BY BARRIER OR GUARDRAIL.
- WHEN PERSONNEL AND/OR EQUIPMENT ARE WORKING WITHIN A LANE OF TRAVEL OF AN UNDIVIDED OR DIVIDED FACILITY, CLOSE THE LANE ACCORDING TO THE TRANSPORTATION MANAGEMENT PLANS, ROADWAY STANDARD DRAWINGS, OR AS DIRECTED BY THE ENGINEER. CONDUCT THE WORK SO THAT ALL PERSONNEL AND/OR EQUIPMENT REMAIN WITHIN THE CLOSED TRAVEL LANE.
- DO NOT WORK SIMULTANEOUSLY WITHIN 15 FT ON BOTH SIDES OF AN OPEN TRAVELWAY, RAMP, OR LOOP WITHIN THE SAME LOCATION UNLESS PROTECTED WITH GUARDRAIL OR BARRIER.
- PROVIDE A MINIMUM OF ONE MILE BETWEEN LANE CLOSURES, MEASURED FROM THE END OF ONE CLOSURE TO THE FIRST SIGN OF THE NEXT CLOSURE.

PAVEMENT EDGE DROP OFF REQUIREMENTS

- BACKFILL AT A 6:1 SLOPE UP TO THE EDGE AND ELEVATION OF EXISTING PAVEMENT IN AREAS ADJACENT TO AN OPENED TRAVEL LANE THAT HAS AN EDGE OF PAVEMENT DROP-OFF AS FOLLOWS:

BACKFILL DROP-OFFS THAT EXCEED 2 INCHES ON ROADWAYS WITH POSTED SPEED LIMITS OF 45 MPH OR GREATER.

BACKFILL DROP-OFFS THAT EXCEED 3 INCHES ON ROADWAYS WITH POSTED SPEED LIMITS LESS THAN 45 MPH.

BACKFILL WITH SUITABLE COMPACTED MATERIAL, AS APPROVED BY THE ENGINEER, AT NO EXPENSE TO THE DEPARTMENT.

- DO NOT EXCEED A DIFFERENCE OF 2 INCHES IN ELEVATION BETWEEN OPEN LANES OF TRAFFIC FOR NOMINAL LIFTS OF 1.5 INCHES. INSTALL ADVANCE WARNING "UNEVEN LANES" SIGNS (W8-11) (350 FEET) IN ADVANCE AND A MINIMUM OF EVERY HALF MILE THROUGHOUT THE UNEVEN AREA.

TRAFFIC PATTERN ALTERATIONS

- NOTIFY THE ENGINEER THIRTY (30) CALENDAR DAYS PRIOR TO ANY TRAFFIC PATTERN ALTERATION.

SIGNING

- INSTALL ADVANCE WORK ZONE WARNING SIGNS WHEN WORK IS WITHIN 40 FT FROM THE EDGE OF TRAVEL LANE AND NO MORE THAN THREE (3) DAYS PRIOR TO THE BEGINNING OF CONSTRUCTION.
- ENSURE ALL NECESSARY SIGNING IS IN PLACE PRIOR TO ALTERING ANY TRAFFIC PATTERN.
- INSTALL BLACK ON ORANGE "DIP" SIGNS (W8-2) AND/OR "BUMP" SIGNS (W8-1) (350 FEET) IN ADVANCE OF THE UNEVEN AREA, OR AS DIRECTED BY THE ENGINEER.

TRAFFIC BARRIER



- INSTALL TEMPORARY BARRIER ACCORDING TO THE TRANSPORTATION MANAGEMENT PLANS A MAXIMUM OF TWO (2) WEEKS PRIOR TO BEGINNING WORK IN ANY LOCATION. ONCE TEMPORARY BARRIER IS INSTALLED AT ANY LOCATION PROCEED IN A CONTINUOUS MANNER TO COMPLETE THE PROPOSED WORK IN THAT LOCATION UNLESS OTHERWISE STATED IN THE TRANSPORTATION MANAGEMENT PLANS OR AS DIRECTED BY THE ENGINEER.

DO NOT PLACE BARRIER DIRECTLY ON ANY SURFACE OTHER THAN ASPHALT OR CONCRETE.

ONCE TEMPORARY BARRIER IS INSTALLED AT ANY LOCATION AND NO WORK IS PERFORMED BEHIND THE TEMPORARY BARRIER FOR A PERIOD LONGER THAN TWO (2) MONTHS, REMOVE / RESET TEMPORARY BARRIER AT NO COST TO THE DEPARTMENT UNLESS OTHERWISE STATED IN THE TRANSPORTATION MANAGEMENT PLANS, TEMPORARY BARRIER IS PROTECTING A HAZARD, OR AS DIRECTED BY THE ENGINEER.

INSTALL TEMPORARY BARRIER WITH THE TRAFFIC FLOW BEGINNING WITH THE UPSTREAM SIDE OF TRAFFIC. REMOVE TEMPORARY BARRIER AGAINST THE TRAFFIC FLOW BEGINNING WITH THE DOWNSTREAM SIDE OF TRAFFIC.

INSTALL AND SPACE DRUMS NO GREATER THAN TWICE THE POSTED SPEED LIMIT (MPH) TO CLOSE OR KEEP THE SECTION OF THE ROADWAY CLOSED UNTIL THE TEMPORARY BARRIER CAN BE PLACED OR AFTER THE TEMPORARY BARRIER IS REMOVED.

APPROVED: _____ DATE: _____ <div style="text-align: center;">  </div>	<div style="text-align: center;">  </div>	<h2 style="margin: 0;">TRANSPORTATION OPERATIONS PLAN</h2>
DOCUMENT NOT CONSIDERED FINAL UNLESS ALL SIGNATURES COMPLETED		

I:\1\2021\USFHUHYF501\Proj\396782_Calyx_R-5014\TrafficControl\TCP\R-5014_TC_TMP_01B.dgn
 User: BJS82185

GENERAL NOTES

TRAFFIC CONTROL DEVICES

- P) WHEN LANE CLOSURES ARE NOT IN EFFECT SPACE CHANNELIZING DEVICES IN WORK AREAS NO GREATER IN FEET THAN TWICE THE POSTED SPEED LIMIT (MPH) EXCEPT, 10 FT ON-CENTER IN RADII, AND 3 FT OFF THE EDGE OF AN OPEN TRAVELWAY. REFER TO STANDARD SPECIFICATIONS FOR ROADS AND STRUCTURES SECTIONS 1130 (DRUMS), 1135 (CONES) AND 1180 (SKINNY DRUMS) FOR ADDITIONAL REQUIREMENTS.
- Q) PLACE TYPE III BARRICADES, WITH "ROAD CLOSED" SIGN R11-2 ATTACHED, OF SUFFICIENT LENGTH TO CLOSE ENTIRE ROADWAY.
- R) PLACE ADDITIONAL SETS OF THREE CHANNELIZING DEVICES PERPENDICULAR TO THE EDGE OF TRAVELWAY ON 500 FT CENTERS WHEN UNOPENED LANES ARE CLOSED TO TRAFFIC.

PAVEMENT MARKINGS AND MARKERS



- S) INSTALL TEMPORARY PAVEMENT MARKINGS AND TEMPORARY PAVEMENT MARKERS ON INTERIM LAYERS OF PAVEMENT AS FOLLOWS:

ROAD NAME	MARKING	MARKER
ALL ROADS	PAINT	NONE
- T) PLACE ONE APPLICATION OF PAINT FOR TEMPORARY TRAFFIC PATTERNS. PLACE A SECOND APPLICATION OF PAINT SIX (6) MONTHS AFTER THE INITIAL APPLICATION AND EVERY SIX MONTHS AS DIRECTED BY THE ENGINEER.
- U) TIE PROPOSED PAVEMENT MARKING LINES TO EXISTING PAVEMENT MARKING LINES.
- V) REMOVE/REPLACE ANY CONFLICTING/DAMAGED PAVEMENT MARKINGS AND MARKERS BY THE END OF EACH DAY'S OPERATION.
- W) TRACE THE PROPOSED MONOLITHIC ISLAND LOCATIONS WITH PROPER COLOR PAVEMENT MARKINGS PRIOR TO INSTALLATION. PLACE DRUMS TO DELINEATE ANY MONOLITHIC ISLANDS BEFORE INSTALLATION.

MISCELLANEOUS

- X) LAW ENFORCEMENT MAY BE USED TO MAINTAIN TRAFFIC THROUGH THE WORK AREA AND/OR INTERSECTIONS AS DIRECTED BY THE ENGINEER.
- Y) IN THE EVENT A TIE-IN CANNOT BE MADE IN ONE DAY'S TIME, BRING THE TIE-IN AREA TO AN APPROPRIATE ROADWAY ELEVATION AS DETERMINED BY THE ENGINEER. PLACE BLACK ON ORANGE "LOOSE GRAVEL" SIGNS (W8-7) AND BLACK ON ORANGE "PAVEMENT ENDS" SIGNS (W8-3) (350 FEET) AND (700 FEET) RESPECTIVELY IN ADVANCE OF THE UNEVEN AREAS. USE DRUMS TO DELINEATE THE EDGE OF ROADWAY ALONG UNPAVED AREAS.
- Z) ALL CURB RAMP LOCATIONS SHALL BE DERIVED FROM STATIONING SHOWN ON PAVEMENT MARKING PLANS OR AS DIRECTED BY THE ENGINEER IN COORDINATION WITH THE SIGNING AND DELINEATION UNIT.
- AA) CONTRACTOR SHALL MAINTAIN SIDEWALK ACCESS AT ALL TIMES AS STATED IN THE PHASING. CONTRACTOR SHALL BE RESPONSIBLE TO PROVIDE TEMPORARY SIDEWALKS (CONCRETE, ASPHALT, OR OTHER SUITABLE MATERIAL AS APPROVED BY THE ENGINEER) AT ALL LOCATIONS WHERE THE OPEN PEDESTRIAN TRAVELWAY HAS BEEN REMOVED FOR CONSTRUCTION OPERATIONS (UTILITIES, DRAINAGE, ETC.).
- BB) DURING CONSTRUCTION, THE PERMITTEE SHALL ATTEMPT TO KEEP THE PARKING AREA AND ACCESS PATH ADJACENT TO THE COLINGTON CREEK BRIDGE OPEN FOR PUBLIC USE AS MUCH AS PRACTICABLE.

4/28/2021
\\USFUDUHVFFS01\Proj\396782_Calyx_R-5014\TrafficControl\TCP\R-5014_TC_TMP_00c.dgn
User:BOY89356

Approved by: <i>David W. Bissette</i> APPROVED: _____ DATE: 4/29/2021 <div style="text-align: center;">  </div>		<h1 style="margin: 0;">TRANSPORTATION OPERATIONS PLAN</h1>
DOCUMENT NOT CONSIDERED FINAL UNLESS ALL SIGNATURES COMPLETED		

SHORING LOCATION NO. 1

FOR TEMPORARY SHORING AND POSITIVE PROTECTION FOR TEMPORARY SHORING, SEE PLANS AND TEMPORARY SHORING PROVISION.

BEFORE BEGINNING TEMPORARY SHORING DESIGN OR CONSTRUCTION, SURVEY EXISTING GROUND ELEVATIONS IN THE VICINITY OF SHORING LOCATIONS TO DETERMINE ACTUAL SHORING HEIGHTS.

DESIGN TEMPORARY SHORING FROM STATION -Y3C- 10+38±, 15.1 FT. RIGHT, TO STATION -Y3C- 10+63±, 15.9 FT. RIGHT, FOR THE FOLLOWING ASSUMED SOIL PARAMETERS AND GROUNDWATER ELEVATION:

- UNIT WEIGHT (γ) = 120 LB/CF
- FRICTION ANGLE (ϕ) = 30 DEGREES
- COHESION (c) = 0 LB/SF
- GROUNDWATER ELEVATION = 2.0 FT ±

DO NOT USE A TEMPORARY WALL FOR TEMPORARY SHORING FROM STATION -Y3C- 10+38±, 15.1 FT. RIGHT, TO STATION -Y3C- 10+63±, 15.9 FT. RIGHT.

SHORING LOCATION NO. 2

FOR TEMPORARY SHORING AND POSITIVE PROTECTION FOR TEMPORARY SHORING, SEE PLANS AND TEMPORARY SHORING PROVISION.

BEFORE BEGINNING TEMPORARY SHORING DESIGN OR CONSTRUCTION, SURVEY EXISTING GROUND ELEVATIONS IN THE VICINITY OF SHORING LOCATIONS TO DETERMINE ACTUAL SHORING HEIGHTS.

DESIGN TEMPORARY SHORING FROM STATION -Y3C- 10+26±, 17.8 FT. LEFT, TO STATION -Y3C- 10+67±, 11.5 FT. LEFT, FOR THE FOLLOWING ASSUMED SOIL PARAMETERS AND GROUNDWATER ELEVATION:

- UNIT WEIGHT (γ) = 120 LB/CF
- FRICTION ANGLE (ϕ) = 30 DEGREES
- COHESION (c) = 0 LB/SF
- GROUNDWATER ELEVATION = 2.0 FT ±

DO NOT USE A TEMPORARY WALL FOR TEMPORARY SHORING FROM STATION -Y3C- 10+26±, 17.8 FT. LEFT, TO STATION -Y3C- 10+67±, 11.5 FT. LEFT.

4/28/2021
\\USFUDUHVHVFPS01\Proj\396782_Calyx_R-5014\TrafficControl\TCP\R-5014_TC_TMP_02.dgn
User:BOY89356

APPROVED: *David W. Bissette*
DATE: 4/29/2021
SEAL
NORTH CAROLINA PROFESSIONAL ENGINEER SEAL 030864 DAVID W. BISSETTE

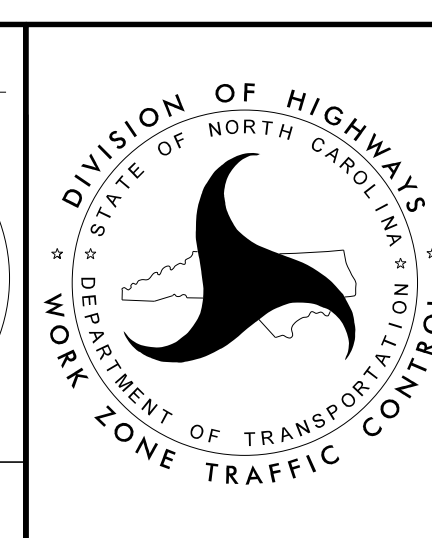

TEMPORARY SHORING DATA

DOCUMENT NOT CONSIDERED FINAL UNLESS ALL SIGNATURES COMPLETED

PHASING

RETURN TRAFFIC TO THE EXISTING PATTERN AT THE END OF EACH DAY.

STEP 1. INSTALL WORK ZONE ADVANCE WARNING SIGNS (SEE RSD 1101.01). INSTALL TEMPORARY "LOW FLYING AIRCRAFT" SIGNS (W14-13 SEE SIGNING PLANS FOR LOCATION).

STEP 2. USING ROADWAY STANDARD DRAWING 1101.02 SHEETS 1 AND 2 OF 14 AND SHEET TMP-5 AS NEEDED, BEGIN CONSTRUCTION OF THE FOLLOWING PROPOSED ROADWAY WIDENING SECTIONS UP TO BUT NOT INCLUDING THE FINAL LAYER OF SURFACE COURSE:

- L- STATION 42+00+/- TO STATION 48+50+/-
- L- STATION 50+00+/- TO STATION 66+00+/-
- L- STATION 75+25+/- TO STATION 90+00+/-
- L- STATION 91+89+/- TO STATION 111+67+/-
- LA- STATION 111+67+/- TO STATION 117+34+/-
- L- STATION 121+00+/- TO STATION 147+22+/-
- L- STATION 152+34+/- TO STATION 209+96+/-
- L- STATION 229+00+/- TO STATION 235+77+/-
- L- STATION 236+49+/- TO STATION 240+00+/-
- Y1A- STATION 11+70+/- TO STATION 13+39+/-
- Y2- STATION 10+15+/- TO STATION 11+34+/-
- Y3- STATION 11+00+/- TO STATION 12+31+/-
- Y3A- STATION 11+60+/- TO STATION 12+63+/-
- Y3B- STATION 11+92+/- TO STATION 12+03+/-
- Y3C- STATION 10+18+/- TO STATION 11+00+/-
- Y4- STATION 10+15+/- TO STATION 11+56+/-
- Y5- STATION 10+70+/- TO STATION 12+55+/-

STEP 3. USING ROADWAY STANDARD DRAWING 1101.02 SHEETS 1 AND 2 OF 14 BEGIN CONSTRUCTION OF THE FOLLOWING PROPOSED FULL DEPTH ROADWAY SECTIONS UP TO BUT NOT INCLUDING THE FINAL LAYER OF SURFACE COURSE: (USE TEMPORARY WEDGING AS NEEDED TO MAINTAIN TRAFFIC ON THE EXISTING ALIGNMENT)

- L- STATION 48+50+/- TO STATION 50+00+/-
- L- STATION 66+00+/- TO STATION 75+25+/-
- LA- STATION 117+34+/- TO STATION 120+03+/-
- L- STATION 120+05+/- TO STATION 121+00+/-
- Y3- STATION 12+31+/- TO STATION 12+59+/-

STEP 4. USING ROADWAY STANDARD DRAWING 1101.02 SHEETS 1 AND 2 OF 14 COMPLETE THE FOLLOWING: (SEE TMP-4)

NOTE: THE WALLS MAY BE CONSTRUCTED IN ANY ORDER PROVIDED A MINIMUM OF 22' OF CLEAR PAVEMENT IS MAINTAINED ON -Y3C- BETWEEN THE ROWS OF WATER FILLED BARRIER.

- INSTALL TEMPORARY PAVEMENT RIGHT OF -Y3C- STATION 10+16+/- TO STATION 10+77+/-.
- INSTALL WATER FILLED BARRIER FROM LEFT OF -L- STATION 107+78+/- TO RIGHT OF -Y3C- STATION 10+70+/-.
- INSTALL TEMPORARY SHORING RIGHT OF -Y3C- STATION 10+38+/- TO STATION 10+63+/-.
- REMOVE THE EXISTING RETAINING WALL RIGHT OF -Y3C- STATION 10+22+/- TO STATION 10+66+/-.
- COLLAR AND EXTEND THE EXISTING 60" CMP WITH 6 LF OF 60" CAAP. (STRUCTURE NO. 1126)
- CONSTRUCT THE PROPOSED RETAINING WALL FROM RIGHT OF -Y3- STATION 10+69+/- TO LEFT OF -L- STATION 107+38+/-.
- REMOVE THE TEMPORARY SHORING.
- REMOVE THE WATER FILLED BARRIER.
- REMOVE THE TEMPORARY PAVEMENT.

- INSTALL TEMPORARY PAVEMENT LEFT OF -Y3C- STATION 10+19+/- TO STATION 11+64+/-.
- INSTALL WATER FILLED BARRIER FROM LEFT OF -Y3C- STATION 10+19+/- TO LEFT OF -Y3C- STATION 10+67+/-.
- INSTALL TEMPORARY SHORING LEFT OF -Y3C- STATION 10+26+/- TO STATION 10+67+/-.
- REMOVE THE EXISTING RETAINING WALL LEFT OF -Y3C- STATION 10+33+/- TO STATION 10+66+/-.
- CONSTRUCT THE PROPOSED RETAINING WALL FROM LEFT OF -Y3C- STATION 10+67+/- TO STATION 10+28+/-.
- REMOVE THE TEMPORARY SHORING.
- REMOVE THE WATER FILLED BARRIER.
- REMOVE THE TEMPORARY PAVEMENT.

STEP 5. USING ROADWAY STANDARD DRAWING 1101.02 SHEETS 1 AND 2 OF 14 COMPLETE CONSTRUCTION OF THE PROPOSED ROADWAY FROM -L- STATION 229+00+/- TO STATION 240+00+/- UP TO BUT NOT INCLUDING THE FINAL LAYER OF SURFACE COURSE.

PLACE TEMPORARY PAVEMENT MARKINGS IN THE FINAL LOCATION (SEE PAVEMENT MARKING PLANS) AND SHIFT TRAFFIC INTO THE FINAL PATTERN FROM -L- STATION 229+00+/- TO STATION 240+00+/-.

USING ROADWAY STANDARD DRAWING 1101.02 SHEETS 1 AND 2 OF 14 COMPLETE CONSTRUCTION OF THE PROPOSED MONOLITHIC ISLAND -L- STATION 233+30+/- TO STATION 235+34+/-.

STEP 6. USING ROADWAY STANDARD DRAWING 1101.02 SHEETS 1 AND 2 OF 14 COMPLETE CONSTRUCTION OF THE FOLLOWING PROPOSED ROADWAY SECTIONS UP TO BUT NOT INCLUDING THE FINAL LAYER OF SURFACE COURSE:

- L- STATION 42+00+/- TO STATION 90+00+/-
- L- STATION 91+89+/- TO STATION 111+67+/-
- LA- STATION 111+67+/- TO STATION 120+03+/-
- L- STATION 120+05+/- TO STATION 147+22+/-
- L- STATION 152+34+/- TO STATION 209+96+/-
- Y1A- STATION 11+70+/- TO STATION 13+39+/-
- Y2- STATION 10+15+/- TO STATION 11+34+/-
- Y3- STATION 11+00+/- TO STATION 12+31+/-
- Y3A- STATION 11+60+/- TO STATION 12+63+/-
- Y3B- STATION 11+92+/- TO STATION 12+03+/-
- Y3C- STATION 10+18+/- TO STATION 11+00+/-
- Y4- STATION 10+15+/- TO STATION 11+56+/-
- Y5- STATION 10+70+/- TO STATION 12+55+/-

STEP 7. USING ROADWAY STANDARD DRAWING 1101.02 SHEETS 1 AND 2 OF 14 PLACE THE FINAL LAYER OF SURFACE COURSE IN THE FOLLOWING LOCATIONS:

- L- STATION 11+00+/- TO STATION 90+00+/-
- L- STATION 91+89+/- TO STATION 111+67+/-
- LA- STATION 111+67+/- TO STATION 120+03+/-
- L- STATION 120+05+/- TO STATION 147+22+/-
- L- STATION 152+34+/- TO STATION 240+00+/-
- Y1- STATION 12+16+/- TO STATION 13+87+/-
- Y1A- STATION 11+70+/- TO STATION 13+39+/-
- Y2- STATION 10+15+/- TO STATION 11+34+/-
- Y3- STATION 11+00+/- TO STATION 12+31+/-
- Y3A- STATION 11+60+/- TO STATION 12+63+/-
- Y3B- STATION 11+92+/- TO STATION 12+03+/-
- Y3C- STATION 10+18+/- TO STATION 11+00+/-
- Y4- STATION 10+15+/- TO STATION 11+56+/-
- Y5- STATION 10+70+/- TO STATION 12+55+/-

STEP 8. PLACE THE FINAL PAVEMENT MARKINGS AND MARKERS IN THE FOLLOWING LOCATIONS (SEE PAVEMENT MARKING PLANS):

- L- STATION 11+00+/- TO STATION 90+00+/-
- L- STATION 91+89+/- TO STATION 111+67+/-
- LA- STATION 111+67 +/- TO STATION 120+03+/-
- L- STATION 120+05+/- TO STATION 147+22+/-
- L- STATION 152+34+/- TO STATION 240+00+/-
- Y1- STATION 12+16+/- TO STATION 13+87+/-
- Y1A- STATION 11+70+/- TO STATION 13+63+/-
- Y2- STATION 10+15+/- TO STATION 11+57+/-
- Y3- STATION 11+00+/- TO STATION 12+78+/-
- Y3A- STATION 11+60+/- TO STATION 12+82+/-
- Y3B- STATION 11+92+/- TO STATION 12+21+/-
- Y3C- STATION 10+00+/- TO STATION 11+00+/-
- Y4- STATION 10+15+/- TO STATION 11+74+/-
- Y5- STATION 10+70+/- TO STATION 12+73+/-

STEP 9. REMOVE ALL TRAFFIC CONTROL DEVICES INCLUDING WORK ZONE ADVANCE WARNING SIGNS.

4/28/2021 \\USFUDUHVH\FPS01\Proj\Calyx_R-5014\TrafficControl\TCP\R-5014_TC_TMP_03.dgn User:HB0Y89356

APPROVED: David W. Bissette
01F5041EA788D1

DATE: 4/29/2021

SEAL



**DOCUMENT NOT CONSIDERED FINAL
UNLESS ALL SIGNATURES COMPLETED**

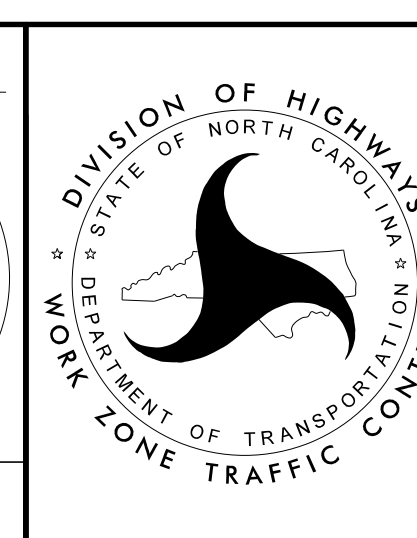

PHASING

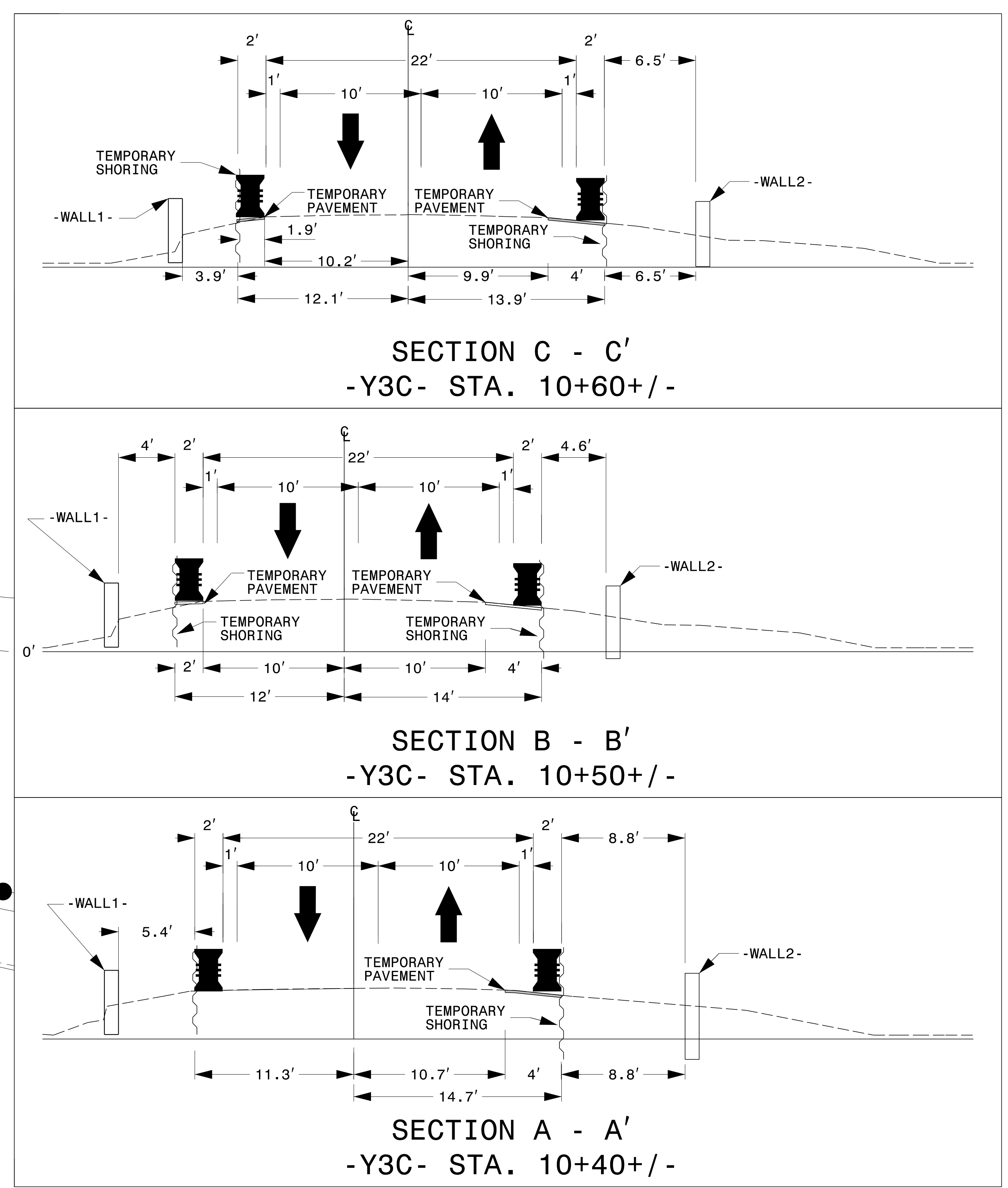
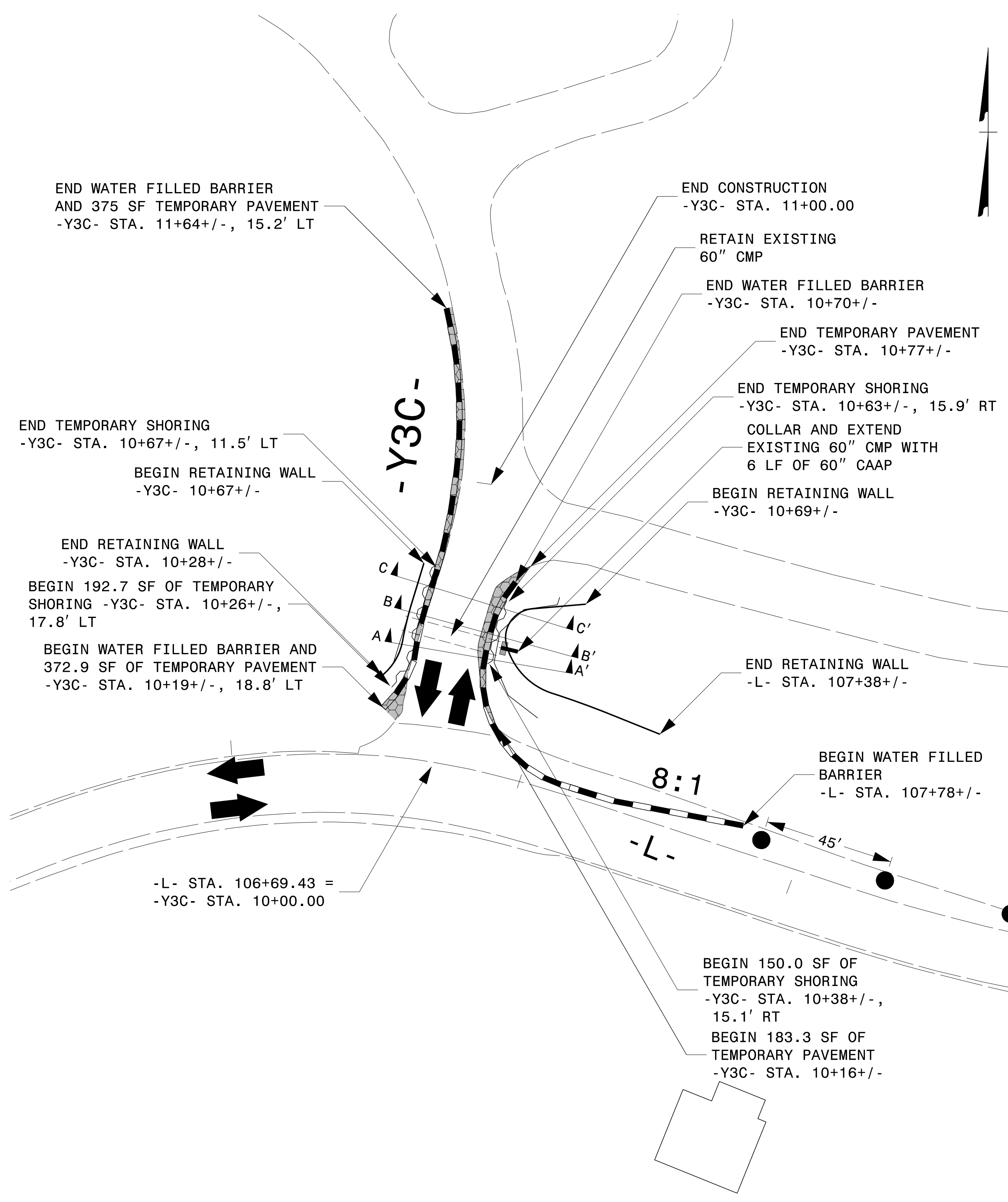

- NOTES**
1. REFER TO THE "TEMPORARY SHORING" PROJECT SPECIAL PROVISION FOR INFORMATION ABOUT TEMPORARY SHORING.
 2. DO NOT PLACE BARRIER DIRECTLY ON ANY SURFACE OTHER THAN ASPHALT OR CONCRETE.
 3. SET BARRIER NEXT TO AND UP AGAINST THE TRAFFIC SIDE OF THE TEMPORARY SHORING.
 4. INSTALL THE WATER FILLED BARRIER PER THE MANUFACTURER'S RECOMMENDATIONS.

APPROVED: *David W. Bissette*
DATE: 4/29/2021

SEAL

DOCUMENT NOT CONSIDERED FINAL UNLESS ALL SIGNATURES COMPLETED

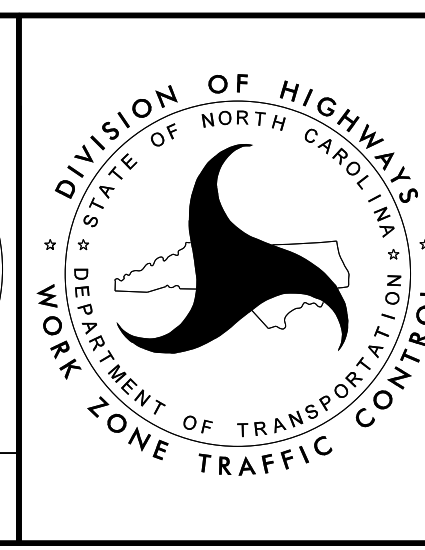

TEMPORARY TRAFFIC CONTROL
TEMPORARY SHORING DETAIL
-WALL1- & -WALL2-

4/28/2021 \\USFH001\HYF501\Proj\396782_Calyx_R-5014\TrafficControl\TCP\R-5014_TC_TMP_04.dgn User:HB0Y89356

PLANS PREPARED FOR THE NC DOT BY:
M MOTT MACDONALD
 MOTT MACDONALD
 100 W. HARRIS STREET, SUITE 100
 RALEIGH, NC 27604
 NC LICENSE NO. F-8669

PROJ. REFERENCE NO.	SHEET NO.
R-5014	TMP-5

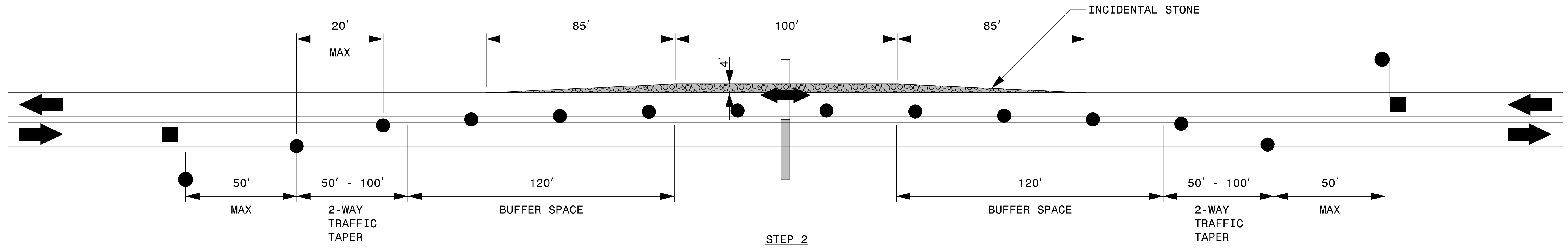
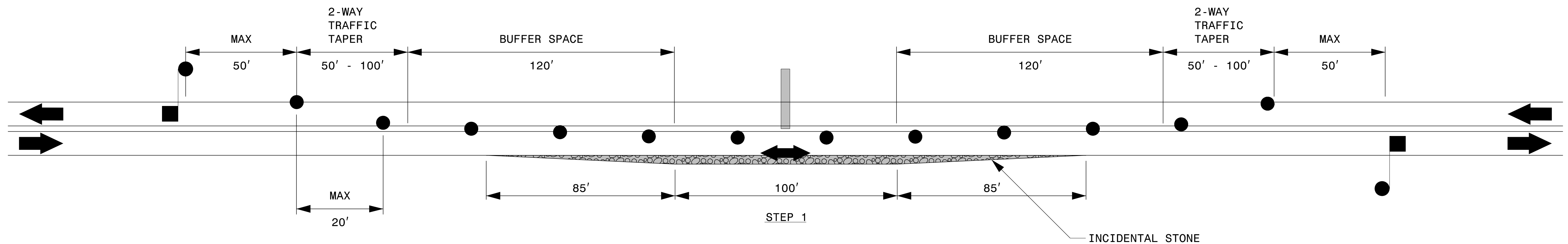

THE ON-SITE DETOUR FOR OPEN CUT PIPE INSTALLATION MAY BE USED FOR, BUT IS NOT LIMITED TO THE FOLLOWING CROSS LINES:

- 18" RCP-IV FROM STRUCTURE 0607 TO STRUCTURE 0613
- TRIPLE 48" CAAP FROM STRUCTURE 0751 TO STRUCTURE 0752
- Dual 60" CAAP FROM STRUCTURE 1050 TO STRUCTURE 1051
- 18" RCP-IV FROM STRUCTURE 1120 TO STRUCTURE 1121
- Dual 42" CAAP FROM STRUCTURE 1250 TO STRUCTURE 1251
- 18" RCP-IV FROM STRUCTURE 1211 TO STRUCTURE 1213
- 30 CAAP FROM STRUCTURE 1520 TO STRUCTURE 1522

NOTES:

1. SEE RSD 1101.02, SHEET 1 OF 14 FOR FLAGGER AND SIGN SPACING REQUIREMENTS.
2. TRAFFIC SHALL BE RETURNED TO THE EXISTING PATTERN AT THE END OF THE WORK PERIOD.

APPROVED: *David W. Bissette*
 DATE: 4/29/2021

Seal: NORTH CAROLINA PROFESSIONAL ENGINEER SEAL 030864 DAVID W. BISSETTE

DOCUMENT NOT CONSIDERED FINAL UNLESS ALL SIGNATURES COMPLETED



ON-SITE DETOUR FOR OPEN-CUT PIPE INSTALLATION

4/28/2021
 \\USFUDUHVHVFPS01\Proj\396782_Calyx_R-5014\TrafficControl\TCP\R-5014_TC_TMP_05.dgn
 User:HB0Y89356