

PLAN  
(TOP OF CAP - BEAMS NOT SHOWN FOR CLARITY)

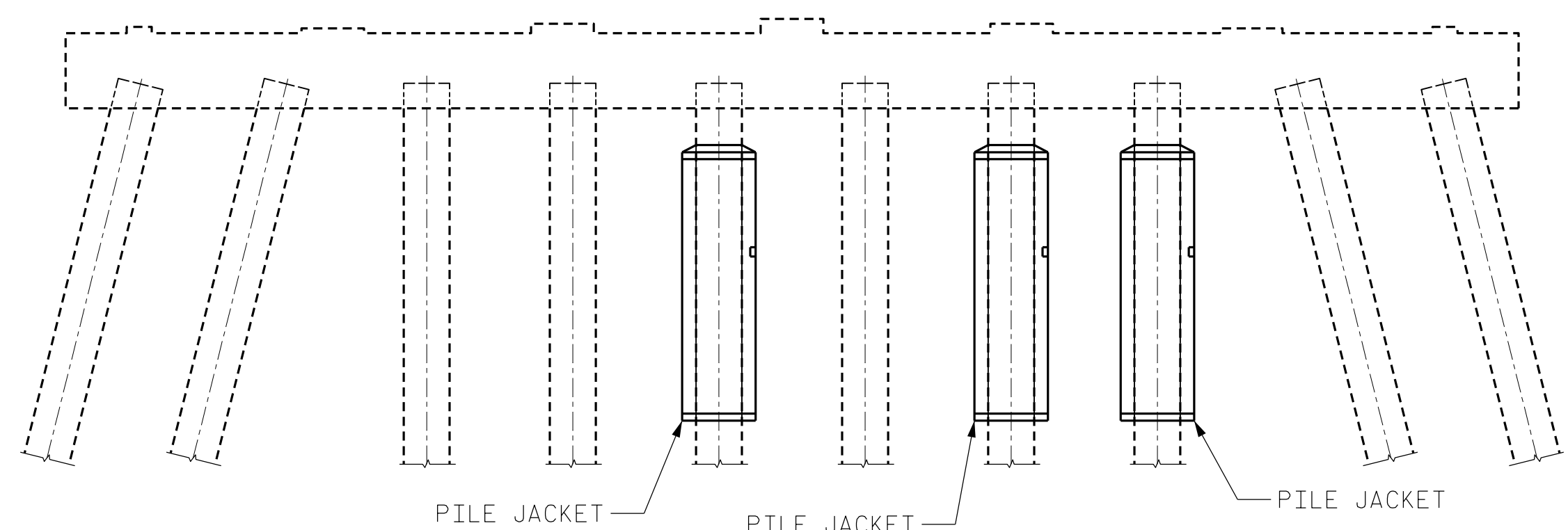

EAST ELEVATION

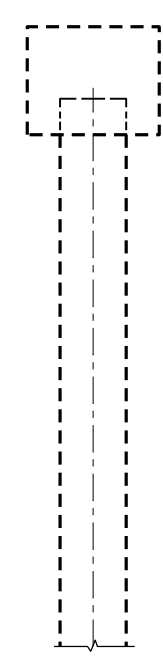

NORTH ELEVATION

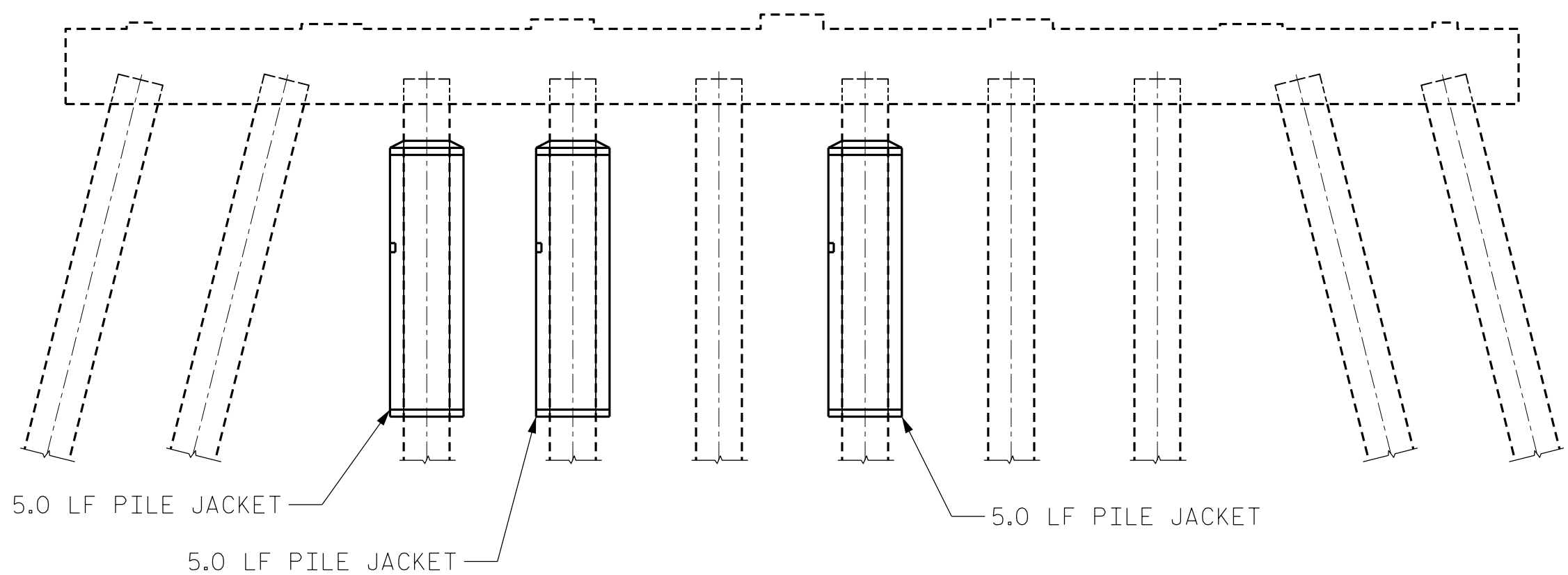

WEST ELEVATION

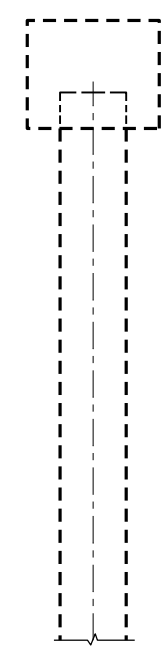

SOUTH ELEVATION

LEGEND	
	CONCRETE REPAIR AREA (CR)
	SHOTCRETE REPAIR AREA (SCR)
	EPOXY RESIN INJECTION (ERI)

	AS-BUILT REPAIR QUANTITY TABLE			
	ESTIMATE		ACTUAL	
SHOTCRETE REPAIRS	AREA SQ. FT.	VOLUME CU. FT.	AREA SQ. FT.	VOLUME CU. FT.
CAP/FOOTING	-	-		
COLUMN/PILE	-	-		
CONCRETE REPAIRS	AREA SQ. FT.	VOLUME CU. FT.	AREA SQ. FT.	VOLUME CU. FT.
* CAP	-	-		
EPOXY RESIN INJECTION	LIN. FT.		LIN. FT.	
CAP	-			
COLUMN/PILE	-			
FOOTING	-			
CP INTEGRAL PILE JACKETS	LIN. FT.		LIN. FT.	
PILE	15.0			

VALUES IN CHART REPRESENT ESTIMATED REPAIR TOTALS AFTER REMOVAL OF UNSOUND CONCRETE, MINIMUM OF 1" BEHIND REBAR AND MINIMUM 2" CLEARANCE TO SAWCUT. FOR REPAIR DETAILS, SEE "CONCRETE RESTORATION DETAILS" SHEETS.

NOTES:

REPAIR LOCATIONS AND ESTIMATED QUANTITIES ARE GIVEN WITH THE BEST INFORMATION AVAILABLE. IF ADDITIONAL REPAIRS NOT SHOWN ON THE DRAWINGS ARE DEEMED NECESSARY BY THE ENGINEER, THE ENGINEER WILL NOTE ON THE DRAWINGS THE APPROXIMATE LOCATIONS AND DESCRIPTION OF THE REPAIRS AND ADJUST THE ACTUAL QUANTITIES ENTERED INTO THE TABLE ABOVE.

CRACKING LOCATIONS AND QUANTITIES FOR LOCATIONS DESCRIBED AS "SCATTERED THROUGHOUT" IN THE INSPECTION REPORT ARE BASED ON THE BEST INFORMATION AVAILABLE. THE ENGINEER AND CONTRACTOR SHALL IDENTIFY AND REPAIR ALL CRACKS  $\geq 1/16"$  AS DESCRIBED IN THE SPECIAL PROVISIONS AT EACH BENT.

AVERAGE CONCRETE COVER IS EXPECTED TO BE FROM 2" TO 3" ON THE CAP AND FROM 1 1/2" TO 2" ON THE PILES. ACTUAL CONCRETE COVER SHALL BE DETERMINED BY THE CONTRACTOR AND PRESENTED TO THE ENGINEER PRIOR TO BEGINNING EXCAVATION AND DEMOLITION.

FOR CONCRETE AND SHOTCRETE REPAIRS, SEE "CONCRETE RESTORATION DETAILS" SHEETS.

SHOTCRETE REPAIRS MAY BE REPLACED WITH CONCRETE REPAIRS WITH THE APPROVAL OF THE ENGINEER.

REPAIRS TO THE BENT CAP MAY REQUIRE BRIDGE JACKING. FOR BRIDGE JACKING, SEE SPECIAL PROVISIONS.

FOR EPOXY COATING, SEE SPECIAL PROVISIONS AND STANDARD SPECIFICATIONS SECTION 420-18.

PROJECT NO. 15BPR.46  
DARE COUNTY  
 BRIDGE NO. 270012



STATE OF NORTH CAROLINA  
 DEPARTMENT OF TRANSPORTATION  
 RALEIGH

**SUBSTRUCTURE REPAIRS**

BENT 65



DRAWN BY : FIDEL L. FLORES DATE : 9/30/2020  
 CHECKED BY : JACOB H. DUKE DATE : 10/1/2020  
 DESIGN ENGINEER OF RECORD: JACOB H. DUKE DATE : 10/1/2020

DOCUMENT NOT CONSIDERED FINAL UNLESS ALL SIGNATURES COMPLETED

REVISIONS						SHEET NO.
NO.	BY:	DATE:	NO.	BY:	DATE:	TOTAL SHEETS
1			3			137
2			4			