

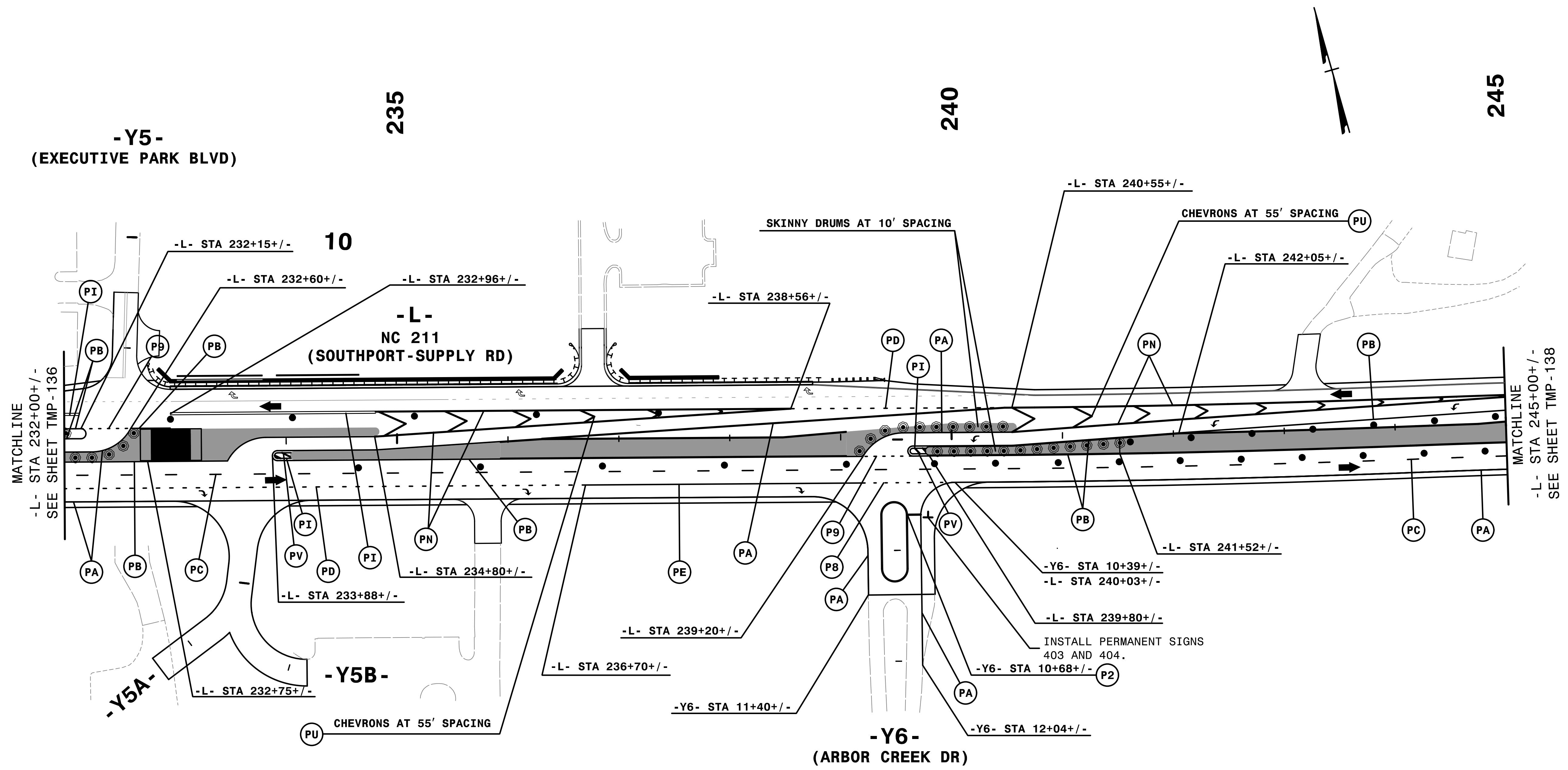

PROJ. REFERENCE NO.	SHEET NO.
R-5021	TMP-137



11:50:33 AM  
 ...\\TCR...5021...p3cell.dgn  
 \$\$\$USERNAME\$\$\$

- REMOVE CONFLICTING PAVEMENT MARKING.
- INSTALL APPLICABLE PERMANENT SIGNS.

**HNTB** HNTB NORTH CAROLINA, P.C.  
 343 E. Six Forks Road, Suite 200  
 Raleigh, North Carolina 27609  
 NC License No: C-1554

APPROVED: *Helen Shyu*  
 DATE: 9/9/2021  
 SEAL  
 DOCUMENT NOT CONSIDERED FINAL  
 UNLESS ALL SIGNATURES COMPLETED

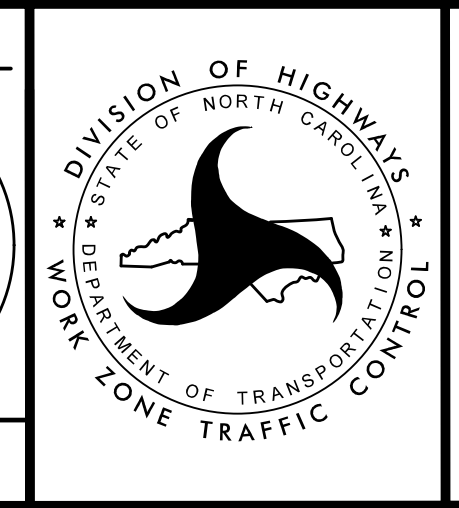

TRANSPORTATION  
 MANAGEMENT PLAN  
 PHASE III  
 DETAIL

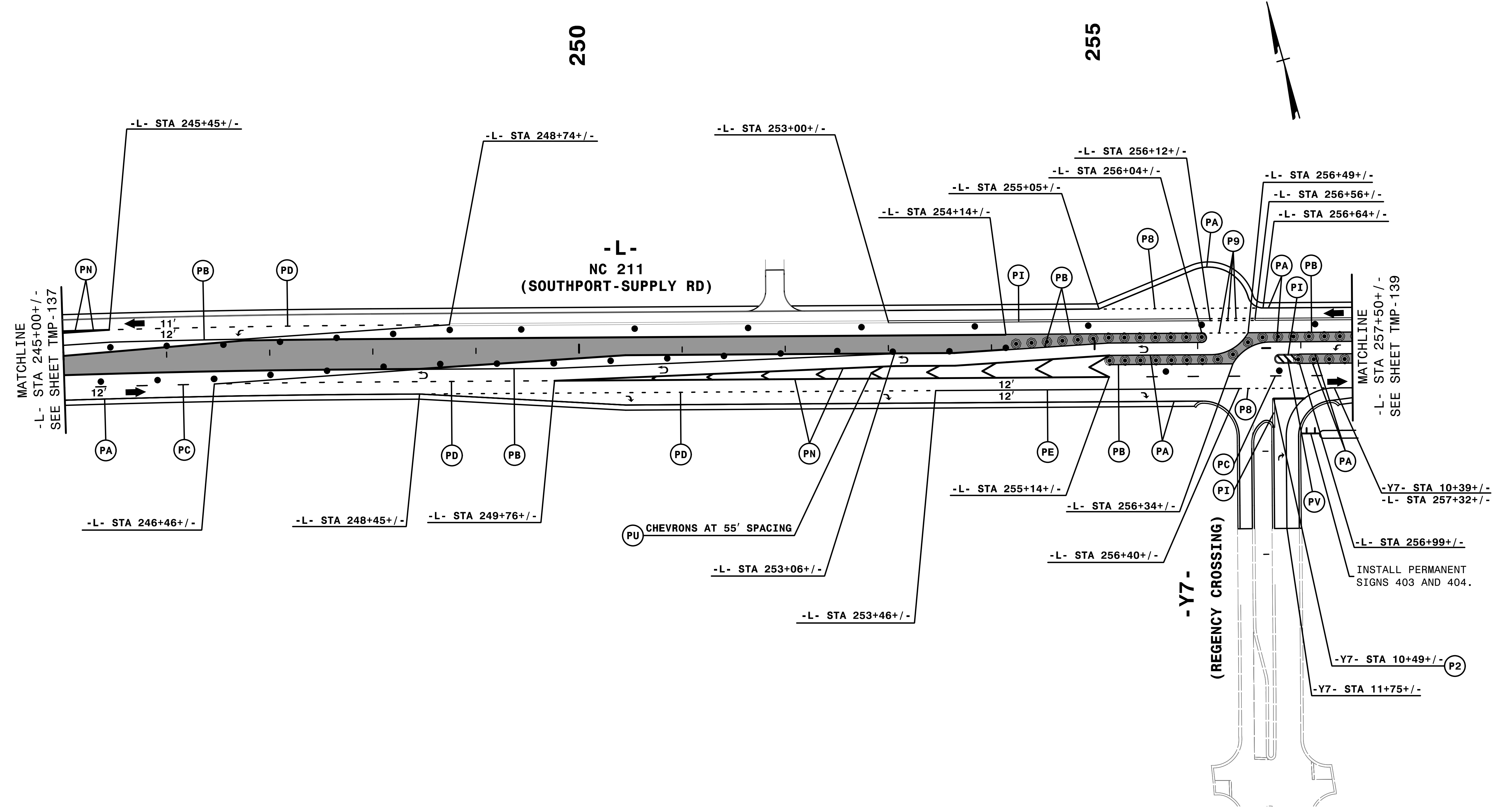

REMOVE CONFLICTING PAVEMENT MARKING.

INSTALL APPLICABLE PERMANENT SIGNS.

4:55:39 PM  
 \\TCFV\F5021\TC\_P3.dwg  
 \$\$\$USERNAME\$\$\$

**HNTB** HNTB NORTH CAROLINA, P.C.  
 343 E. Six Forks Road, Suite 200  
 Raleigh, North Carolina 27609  
 NC License No: C-1554

APPROVED: *Helen Shyu*  
 DATE: 9/9/2021  
 SEAL  
 DOCUMENT NOT CONSIDERED FINAL  
 UNLESS ALL SIGNATURES COMPLETED

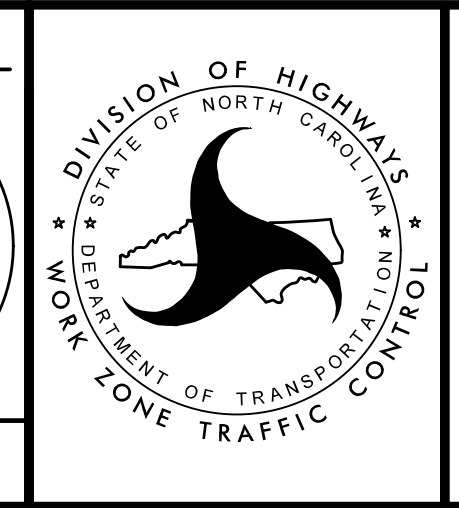

TRANSPORTATION  
 MANAGEMENT PLAN

PHASE III  
 DETAIL

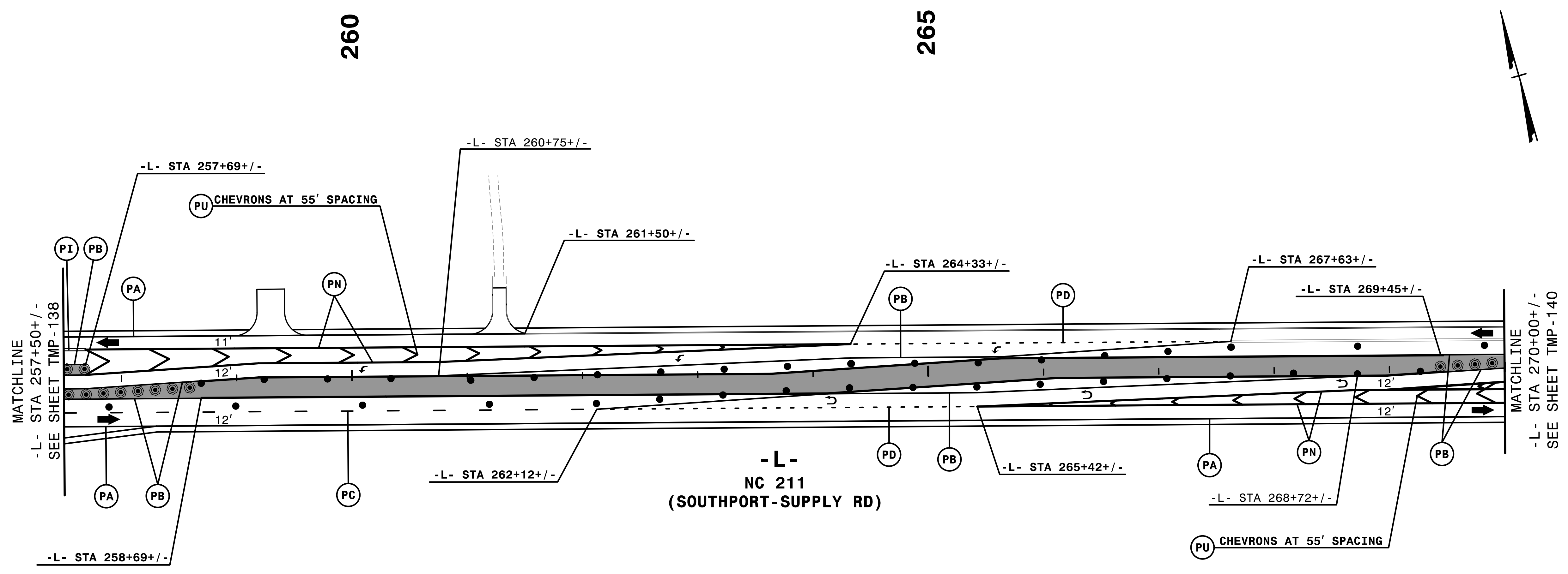

MATCHLINE  
-L- STA 257+50+/-  
SEE SHEET TMP-138

MATCHLINE  
-L- STA 270+00+/-  
SEE SHEET TMP-140

-L-  
NC 211  
(SOUTHPORT-SUPPLY RD)

2/6/2019  
HNTB  
C:\CPV\5021\c-p3d13.dgn

- REMOVE CONFLICTING PAVEMENT MARKING.
- INSTALL APPLICABLE PERMANENT SIGNS.



APPROVED: *Helen Skyy*  
DATE: 2/6/2019

SEAL

DOCUMENT NOT CONSIDERED FINAL  
UNLESS ALL SIGNATURES COMPLETED

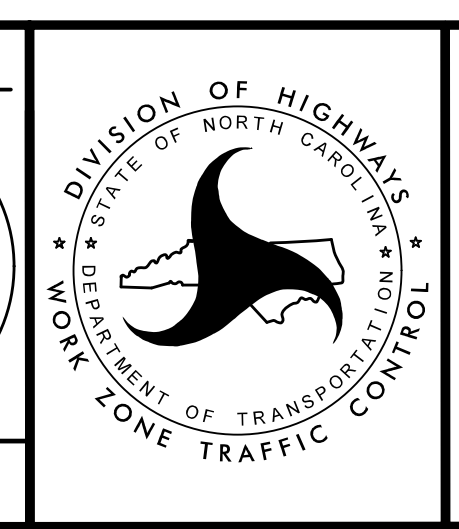

TRANSPORTATION  
MANAGEMENT PLAN

PHASE III  
DETAIL

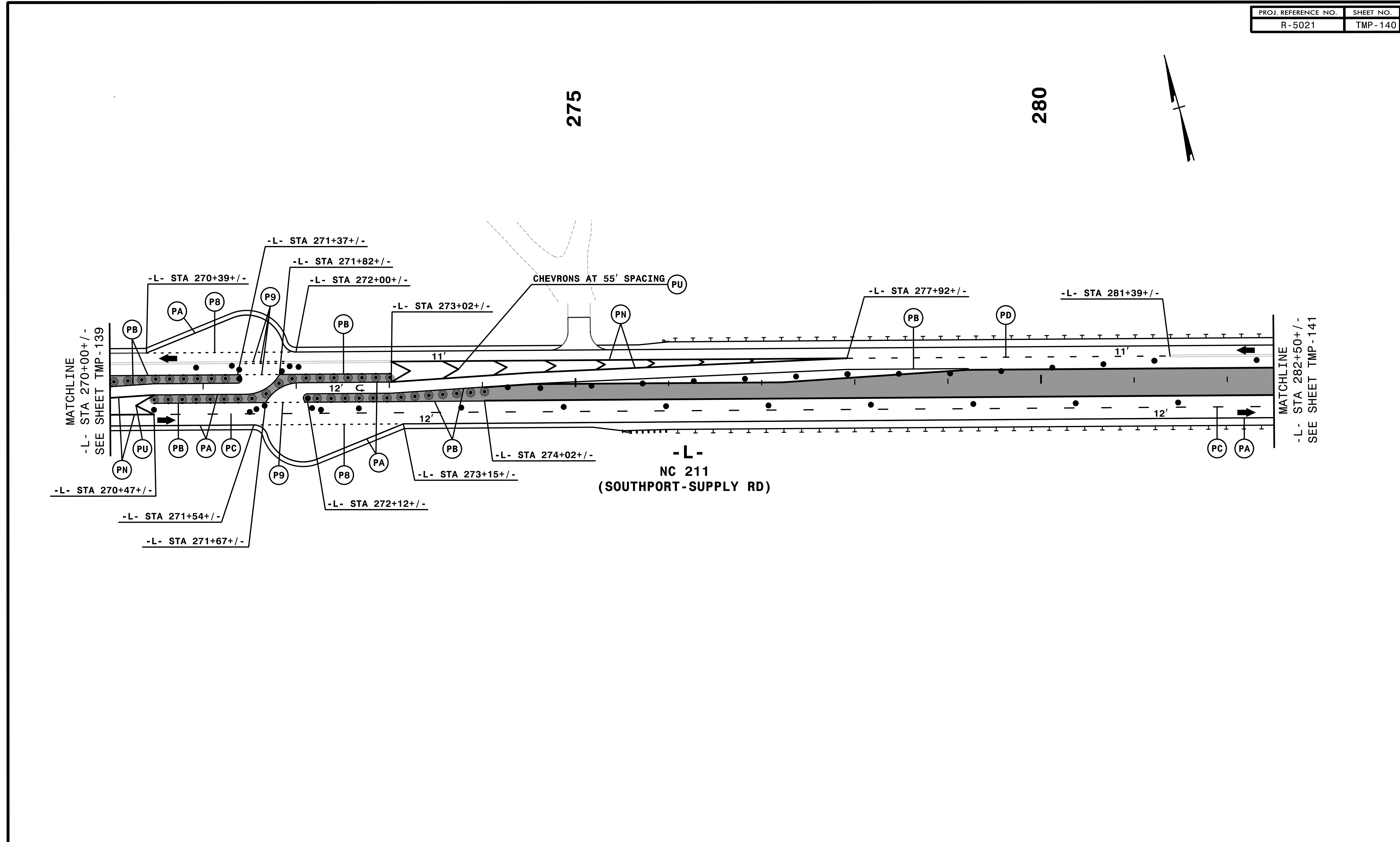

11:50:37 AM  
...\\TC\p\5021\to\_p3.dwg  
\$\$\$\$\$USERNAME\$\$\$\$\$

REMOVE CONFLICTING PAVEMENT MARKING.

INSTALL APPLICABLE PERMANENT SIGNS.



APPROVED: *Helen Shyu*

DATE: 9/9/2021

SEAL

DOCUMENT NOT CONSIDERED FINAL  
UNLESS ALL SIGNATURES COMPLETED

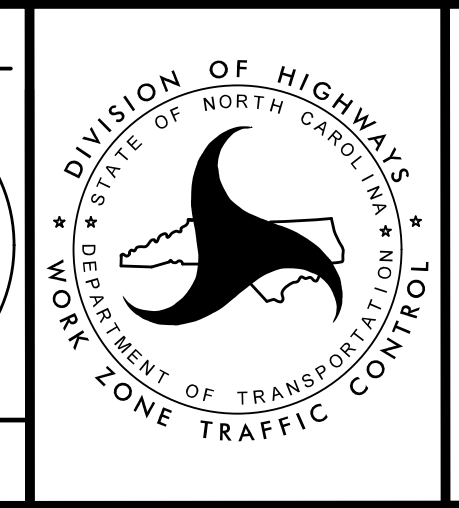

TRANSPORTATION  
MANAGEMENT PLAN

PHASE III  
DETAIL

PROJ. REFERENCE NO.	SHEET NO.
R-5021	TMP-141

①

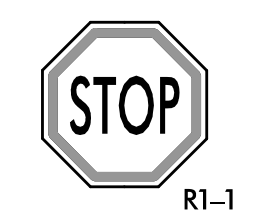

285

290

295

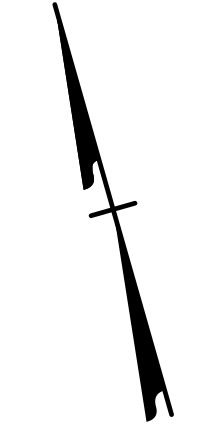

-L-  
NC 211  
(SOUTHPORT-SUPPLY RD)

MATCHLINE  
-L- STA 282+50+/-  
SEE SHEET TMP-140

MATCHLINE  
-L- STA 296+00+/-  
SEE SHEET TMP-142

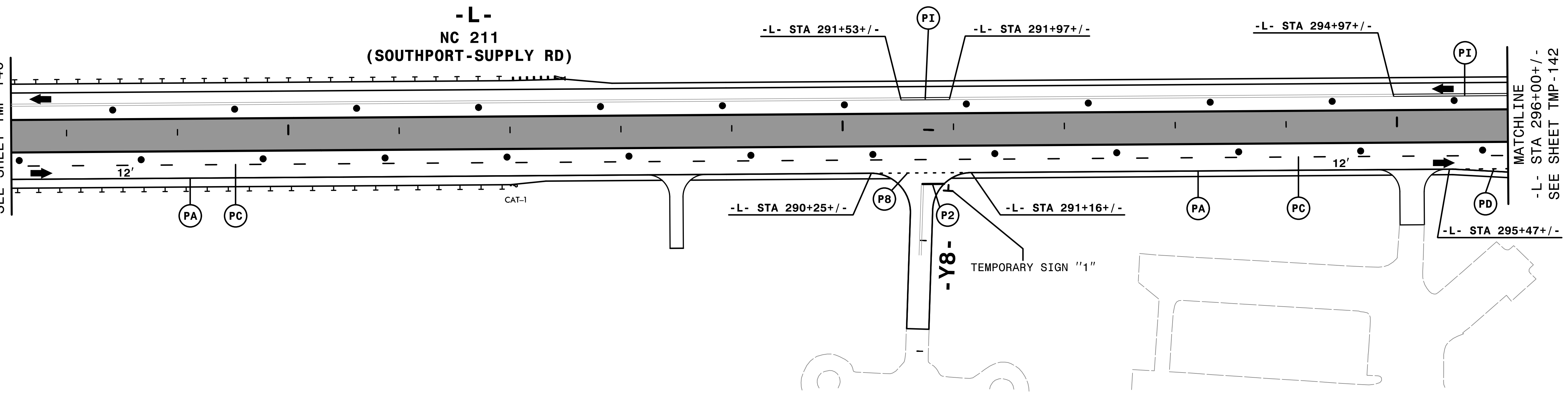

4:55:43 PM  
...\\TC\...5021\_Tc\_p3d15.dgn  
\$\$\$USERNAME\$\$\$

- REMOVE CONFLICTING PAVEMENT MARKING.
- INSTALL APPLICABLE PERMANENT SIGNS.

**HNTB** HNTB NORTH CAROLINA, P.C.  
343 E. Six Forks Road, Suite 200  
Raleigh, North Carolina 27609  
NC License No: C-1554

APPROVED: *Helen Shyu*  
DATE: 9/9/2021  
SEAL  
DOCUMENT NOT CONSIDERED FINAL  
UNLESS ALL SIGNATURES COMPLETED

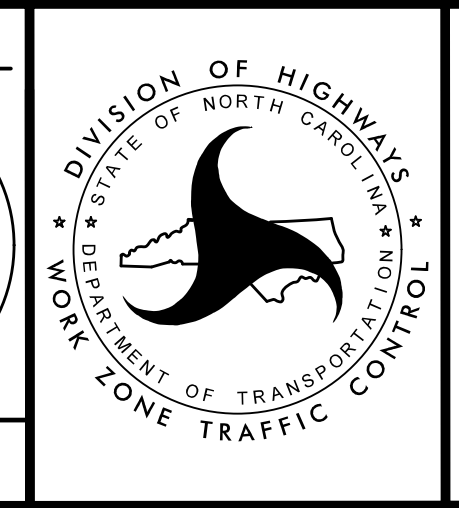

DIVISION OF HIGHWAYS  
STATE OF NORTH CAROLINA  
DEPARTMENT OF TRANSPORTATION  
WORK ZONE TRAFFIC CONTROL

TRANSPORTATION  
MANAGEMENT PLAN  
PHASE III  
DETAIL

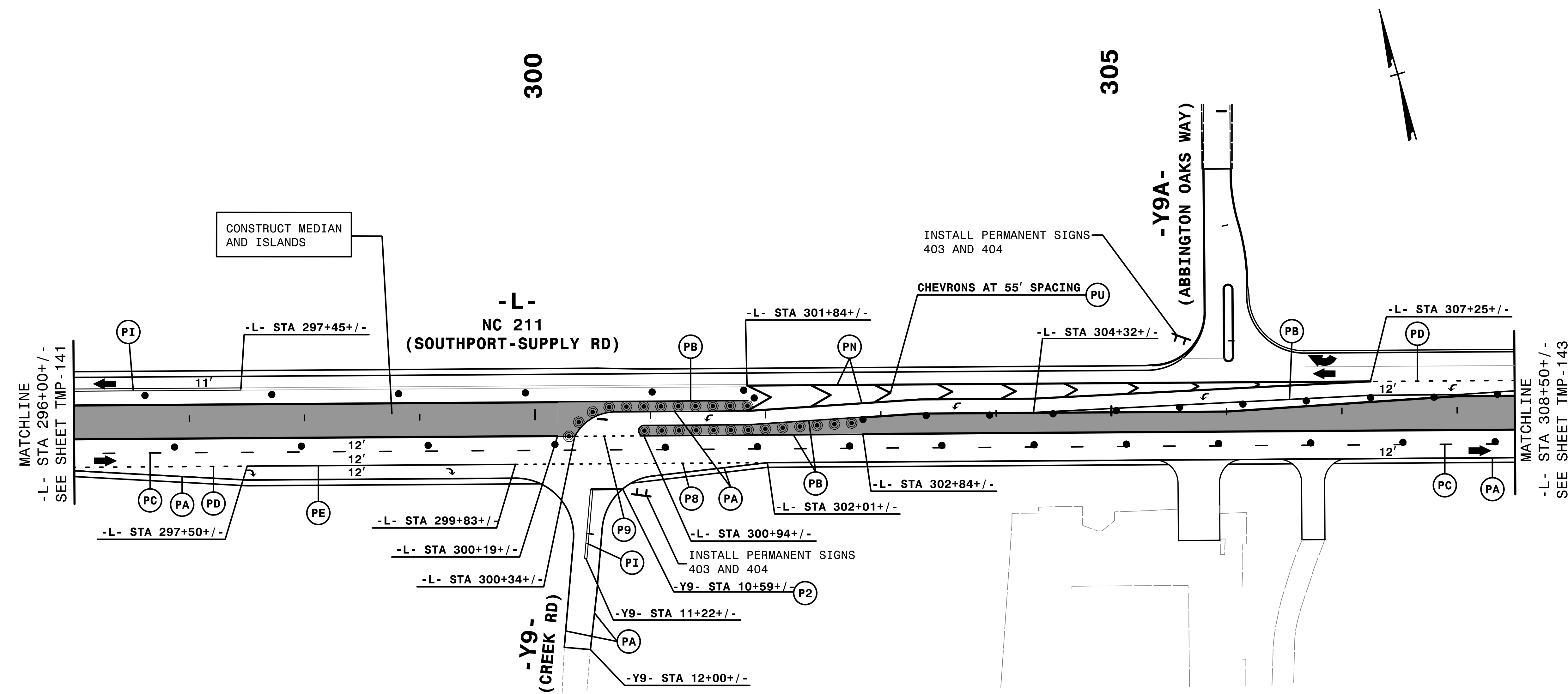

2:31:00 PM  
 \\TCFV\5021\TC\_P3.dwg  
 \$\$\$USERNAME\$\$\$

REMOVE CONFLICTING PAVEMENT MARKING.  
 INSTALL APPLICABLE PERMANENT SIGNS.

**HNTB** HNTB NORTH CAROLINA, P.C.  
 343 E. Six Forks Road, Suite 200  
 Raleigh, North Carolina 27609  
 NC License No: C-1554

APPROVED: *Helen Shyu*  
 DATE: 10/28/2021  
 SEAL  
 DOCUMENT NOT CONSIDERED FINAL  
 UNLESS ALL SIGNATURES COMPLETED

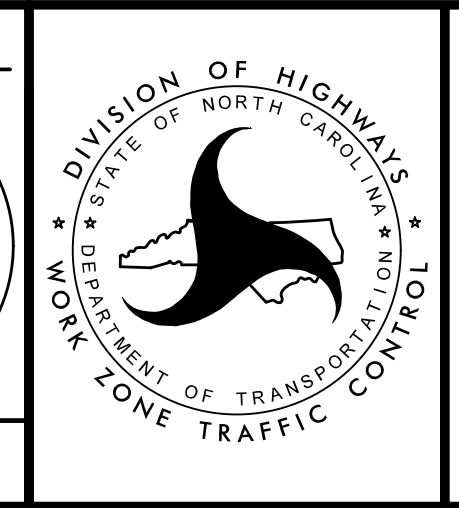

TRANSPORTATION  
 MANAGEMENT PLAN  
 PHASE III  
 DETAIL





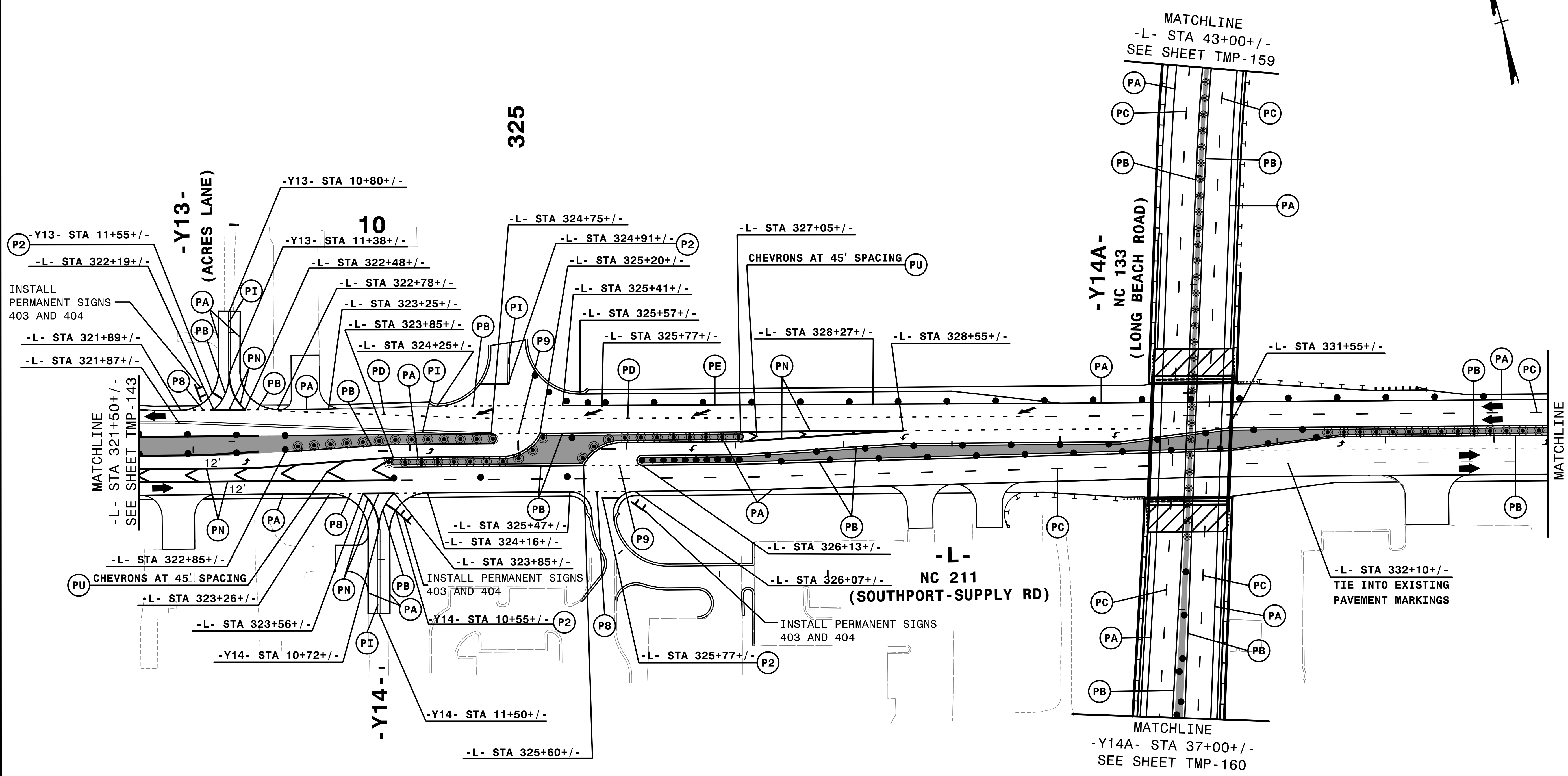
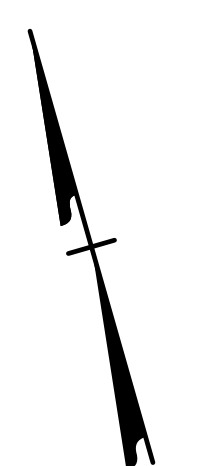

APPROVED: *Helen Shyu*  
OF 19975A95E4AEF

DATE: 9/9/2021

SEAL

DOCUMENT NOT CONSIDERED FINAL  
UNLESS ALL SIGNATURES COMPLETED

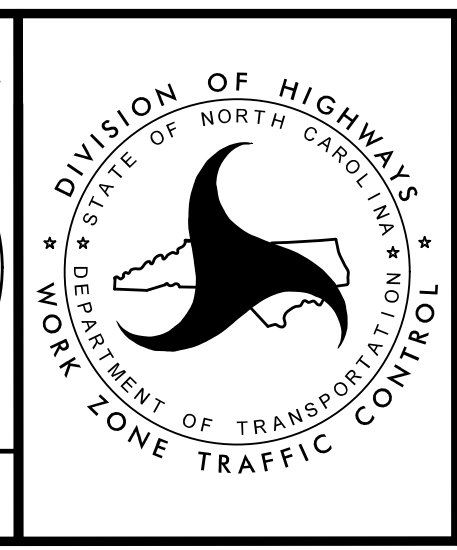

TRANSPORTATION  
MANAGEMENT PLAN

PHASE III  
DETAIL

4:55:50 PM  
 \\TCPL\F5021\Tc.p3\d18.dgn  
 \$\$\$USERNAME\$\$\$



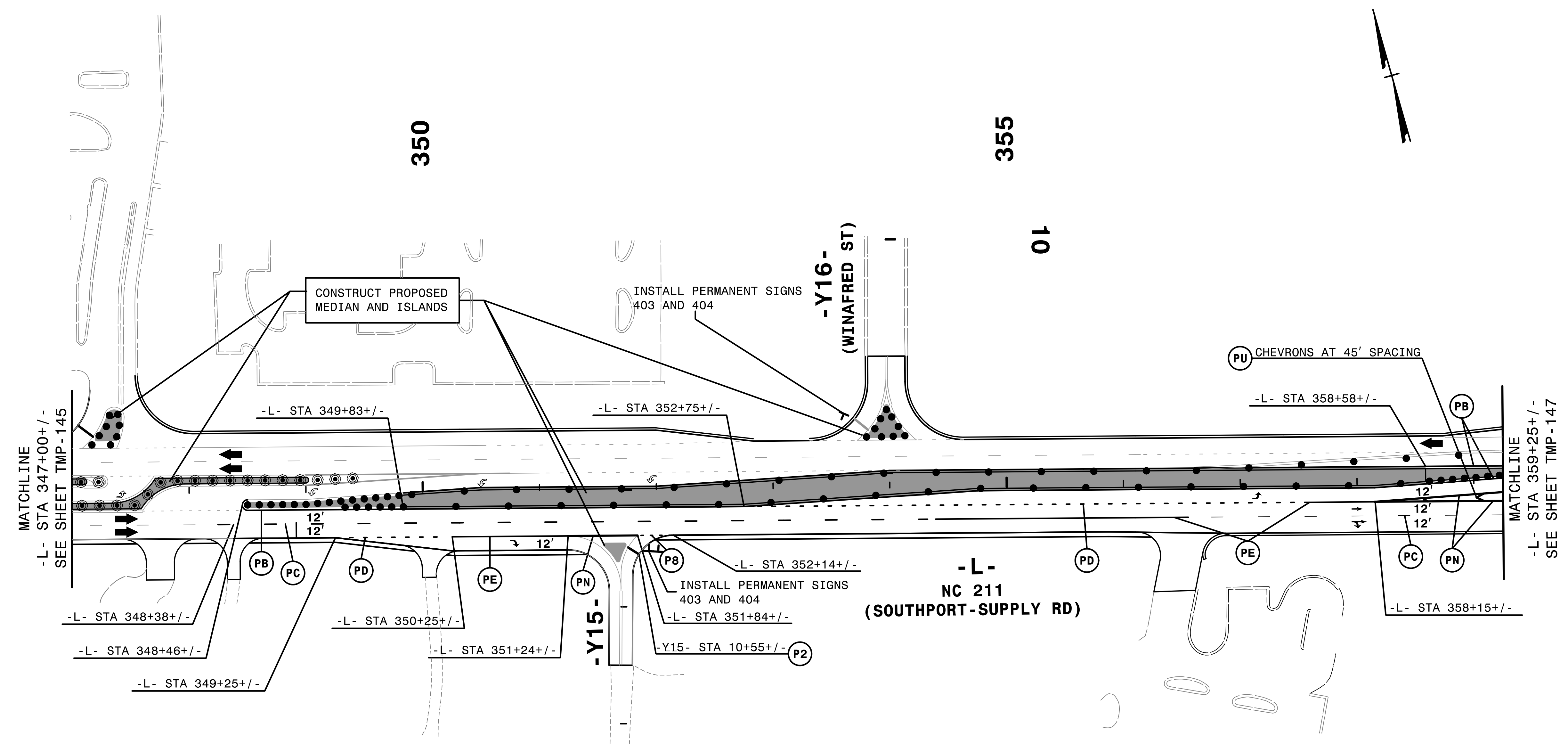

4:55:55 PM  
 ...\\TCR\...5021\...p3420.dgn  
 \$\$\$USERNAME\$\$\$

- REMOVE CONFLICTING PAVEMENT MARKING.
- INSTALL APPLICABLE PERMANENT SIGNS.

**HNTB** HNTB NORTH CAROLINA, P.C.  
 343 E. Six Forks Road, Suite 200  
 Raleigh, North Carolina 27609  
 NC License No: C-1554

APPROVED: *Helen Shyu*  
 DATE: 9/9/2021  
 SEAL  
 DOCUMENT NOT CONSIDERED FINAL  
 UNLESS ALL SIGNATURES COMPLETED

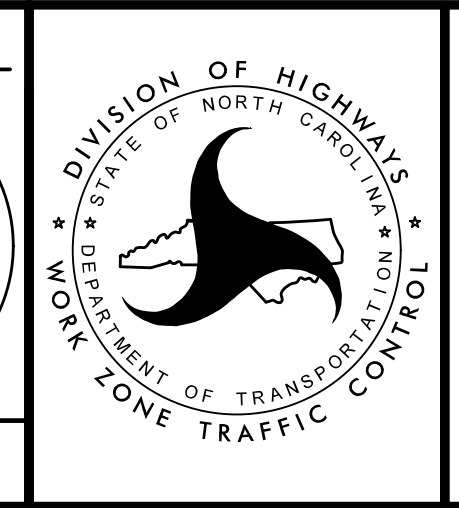

TRANSPORTATION  
 MANAGEMENT PLAN  
 PHASE III  
 DETAIL

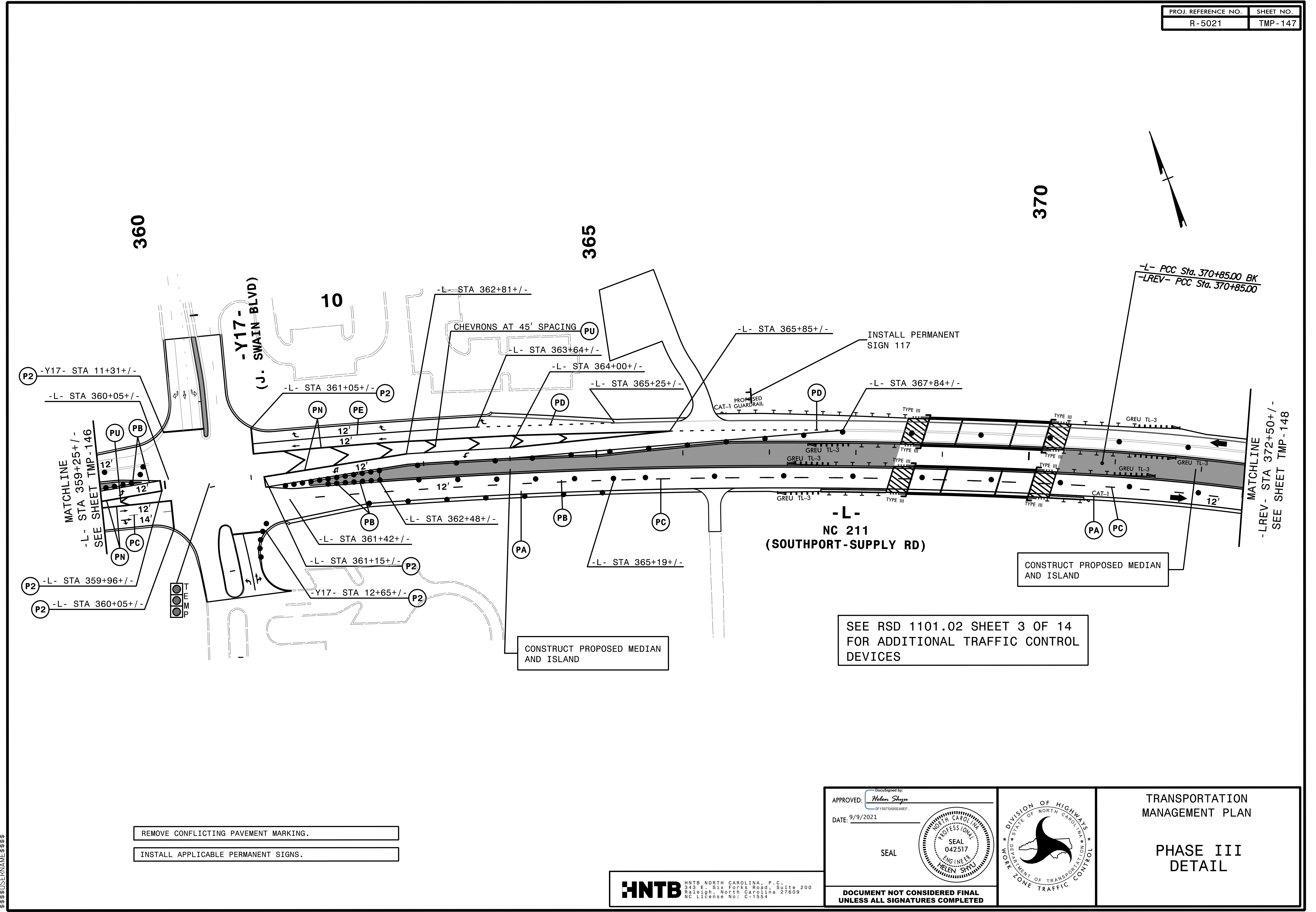

REMOVE CONFLICTING PAVEMENT MARKING.

INSTALL APPLICABLE PERMANENT SIGNS.

4:55:57 PM  
 \\TCN\F5021\TC\_P3d21.dgn  
 \$\$\$USERNAME\$\$\$

**HNTB** HNTB NORTH CAROLINA, P.C.  
 343 E. Six Forks Road, Suite 200  
 Raleigh, North Carolina 27609  
 NC License No: C-1554

APPROVED: *Helen Shyu*  
 DATE: 9/9/2021  
 SEAL  
 DOCUMENT NOT CONSIDERED FINAL  
 UNLESS ALL SIGNATURES COMPLETED

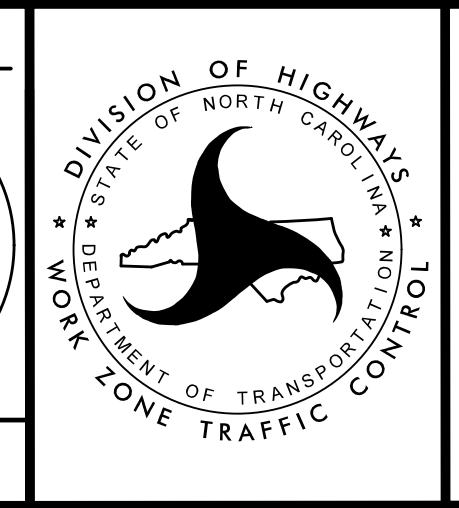

TRANSPORTATION  
 MANAGEMENT PLAN

PHASE III  
 DETAIL



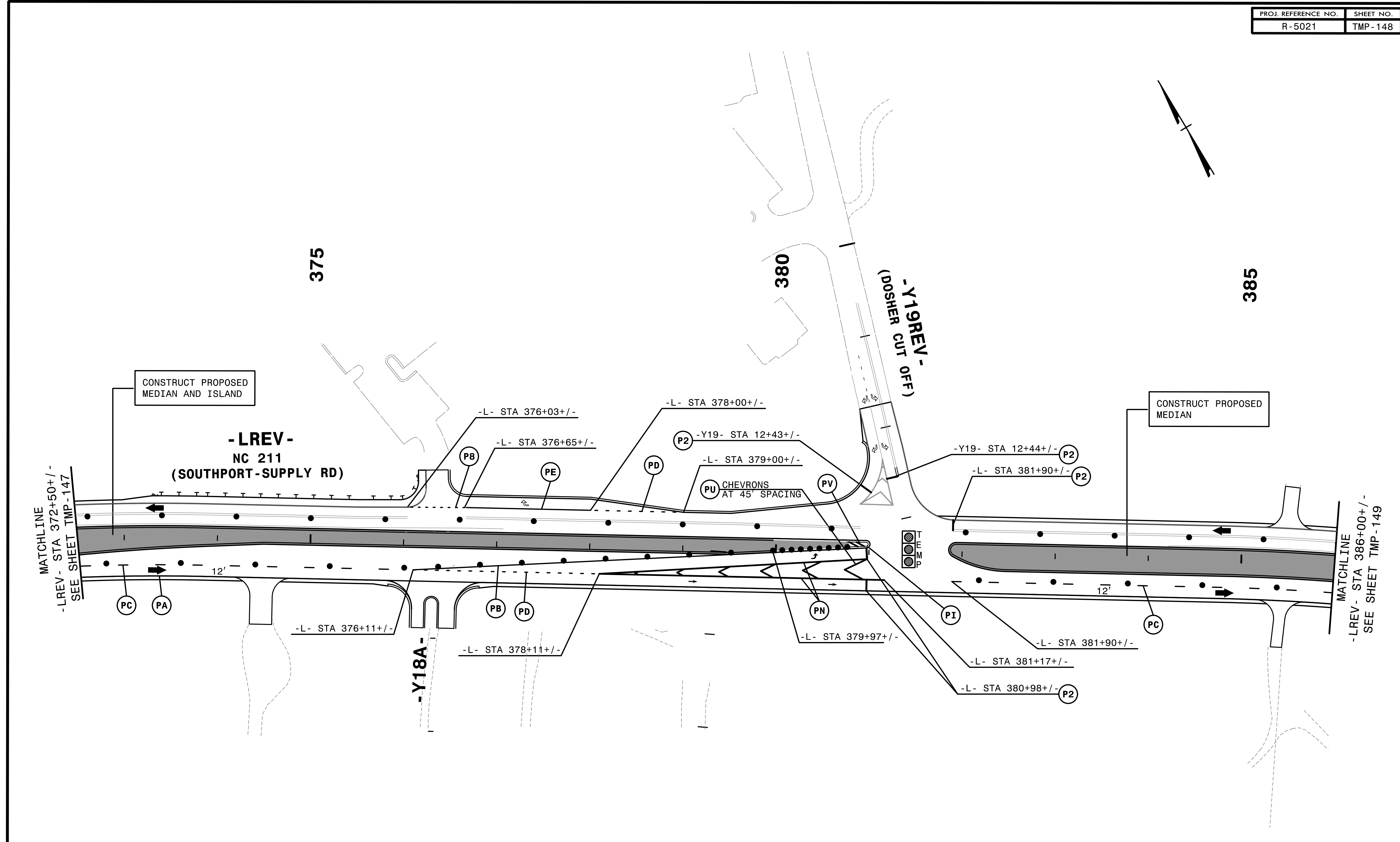

4:41:28 PM  
 \\TCPLV502L1\c\_p3422.dgn  
 \$\$\$USERNAME\$\$\$

- REMOVE CONFLICTING PAVEMENT MARKING.
- INSTALL APPLICABLE PERMANENT SIGNS.

**HNTB** HNTB NORTH CAROLINA, P.C.  
 343 E. Six Forks Road, Suite 200  
 Raleigh, North Carolina 27609  
 NC License No: C-1554

APPROVED: *Helen Shyne*  
 DATE: 9/9/2021  
 SEAL  
 DOCUMENT NOT CONSIDERED FINAL  
 UNLESS ALL SIGNATURES COMPLETED

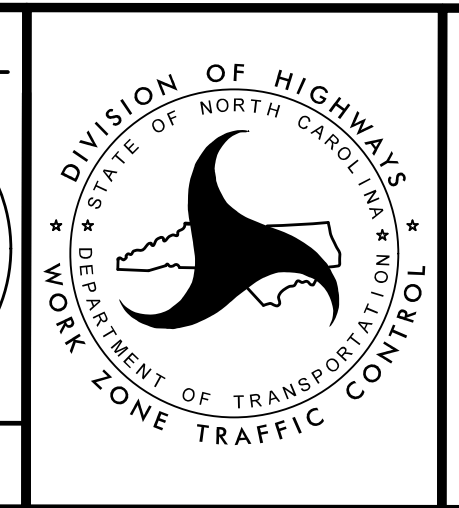

TRANSPORTATION  
 MANAGEMENT PLAN  
 PHASE III  
 DETAIL



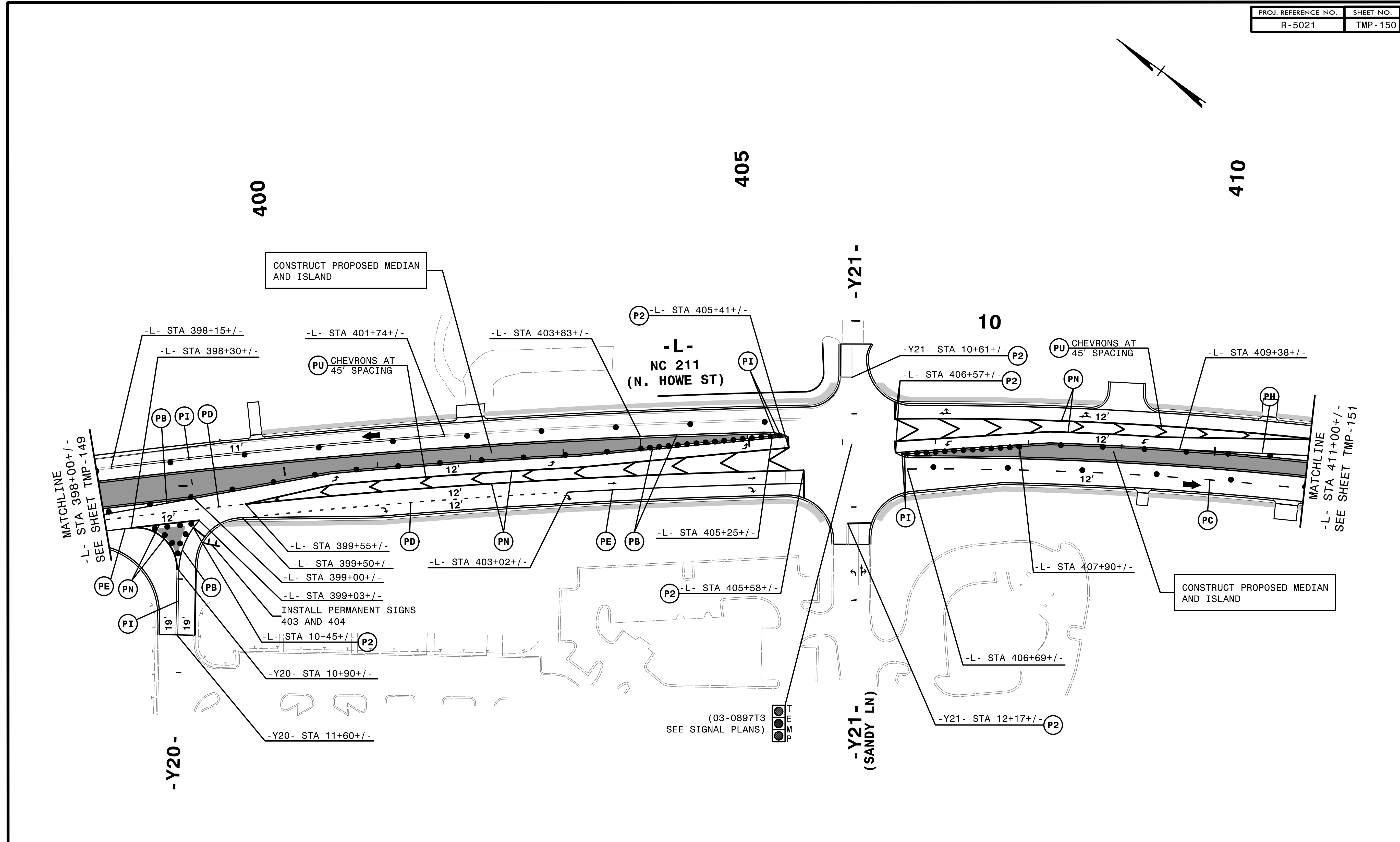

4:56:03 PM  
 \\TCFV15021\c\_p3d24.dgn  
 \$\$\$USERNAME\$\$\$

- REMOVE CONFLICTING PAVEMENT MARKING.
- INSTALL APPLICABLE PERMANENT SIGNS.

(03-0897T3  
SEE SIGNAL PLANS)

**HNTB** HNTB NORTH CAROLINA, P.C.  
 343 E. Six Forks Road, Suite 200  
 Raleigh, North Carolina 27609  
 NC License No: C-1554

APPROVED: *Helen Shyu*  
 DATE: 9/9/2021  
 SEAL  
 PROFESSIONAL ENGINEER  
 SEAL 042517  
 HELEN SHYU

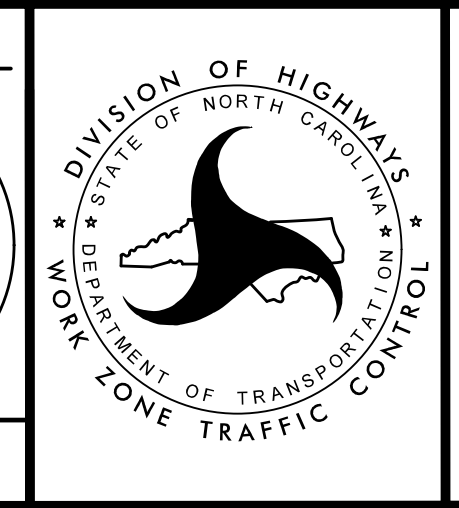

TRANSPORTATION  
MANAGEMENT PLAN

PHASE III  
DETAIL

DOCUMENT NOT CONSIDERED FINAL  
UNLESS ALL SIGNATURES COMPLETED

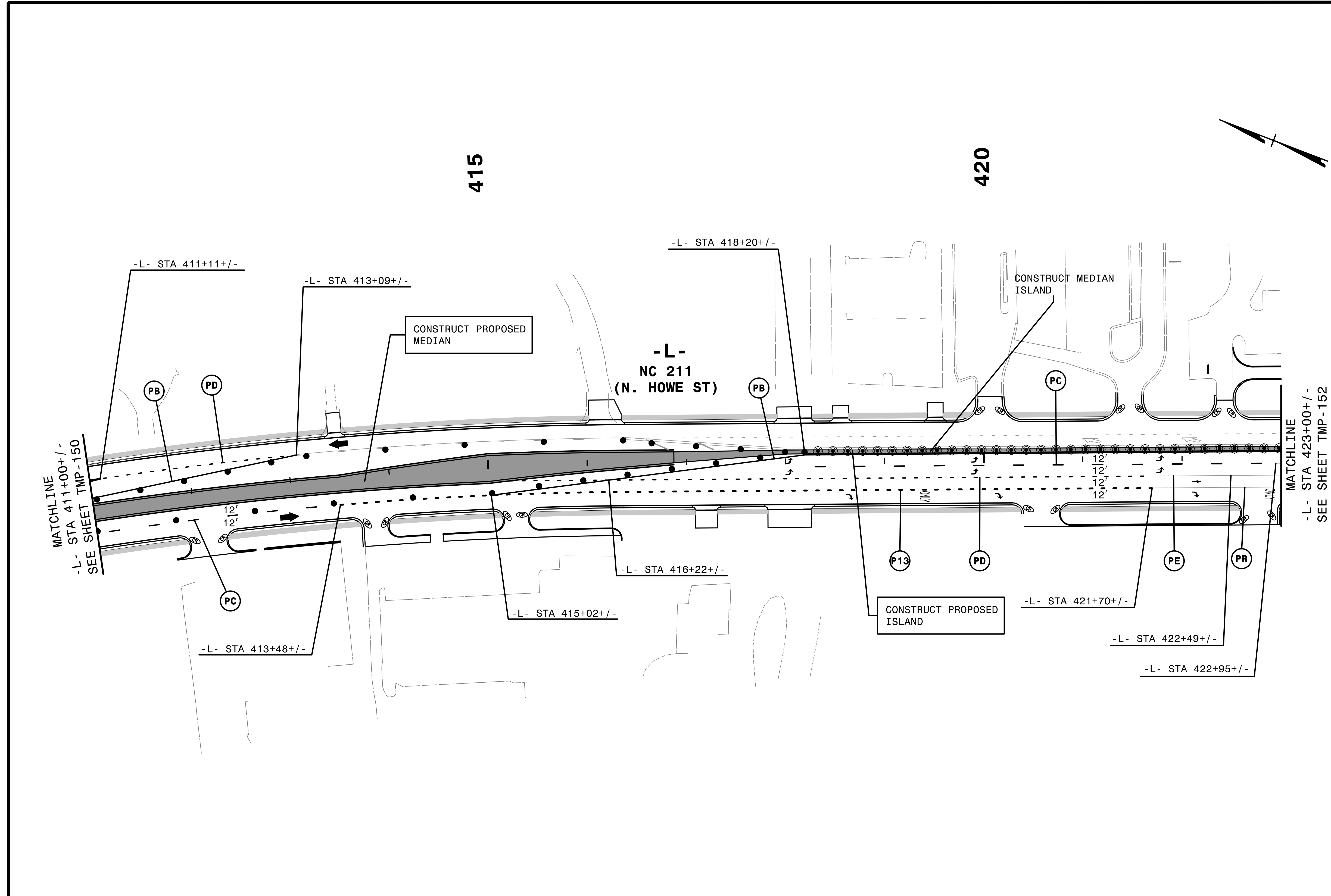

2/6/2019  
 C:\CPV\5021\to\_p3d25.dgn  
 HNTB

- INSTALL APPLICABLE PERMANENT SIGNS.
- REMOVE CONFLICTING PAVEMENT MARKING.



APPROVED: *Helen Skyy*  
OR 1987SAPPROVAL

DATE: 2/6/2019

SEAL

**DOCUMENT NOT CONSIDERED FINAL  
UNLESS ALL SIGNATURES COMPLETED**

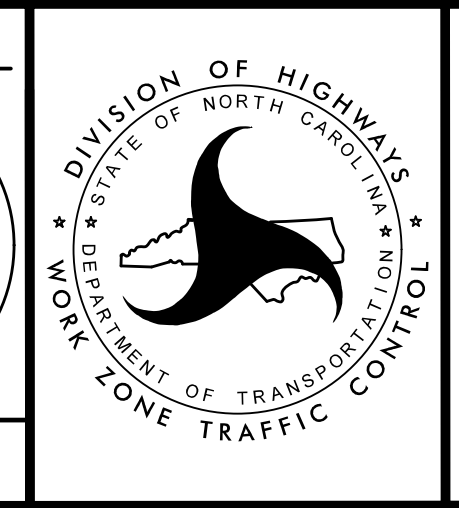

TRANSPORTATION  
MANAGEMENT PLAN

PHASE III  
DETAIL



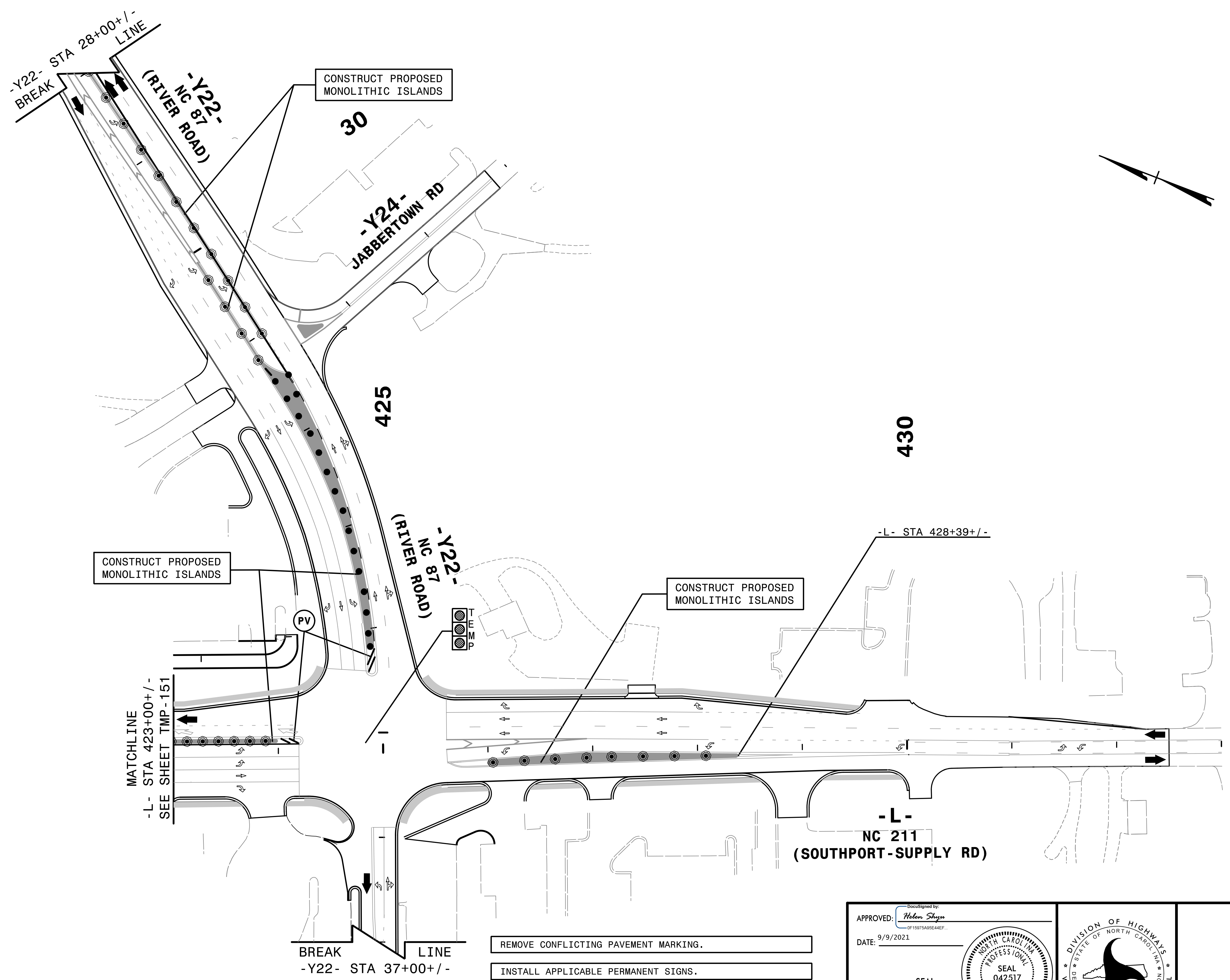

4:56:06 PM  
 \\TCPL\F5021\TC\_P33d26.dgn  
 \$\$\$USERNAME\$\$\$

BREAK LINE  
 -Y22- STA 37+00+/-

- REMOVE CONFLICTING PAVEMENT MARKING.
- INSTALL APPLICABLE PERMANENT SIGNS.



APPROVED: *Helen Shyu*  
OF 15975A95E4EF  
 DATE: 9/9/2021  
 SEAL  
**DOCUMENT NOT CONSIDERED FINAL  
 UNLESS ALL SIGNATURES COMPLETED**

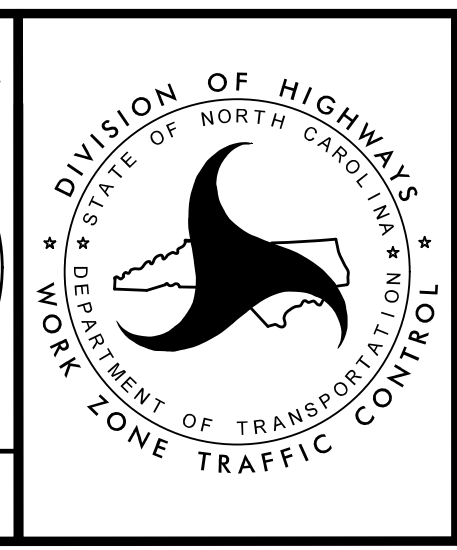

TRANSPORTATION  
 MANAGEMENT PLAN  
  
 PHASE III  
 DETAIL

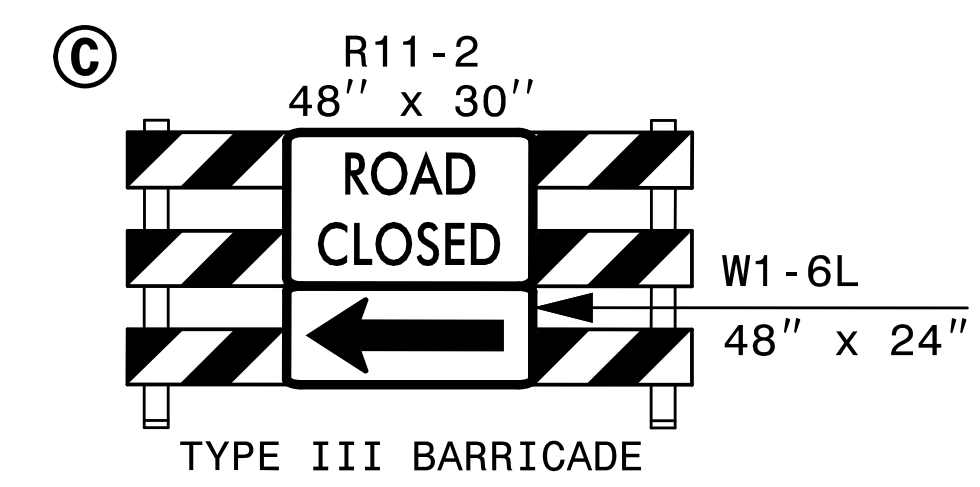
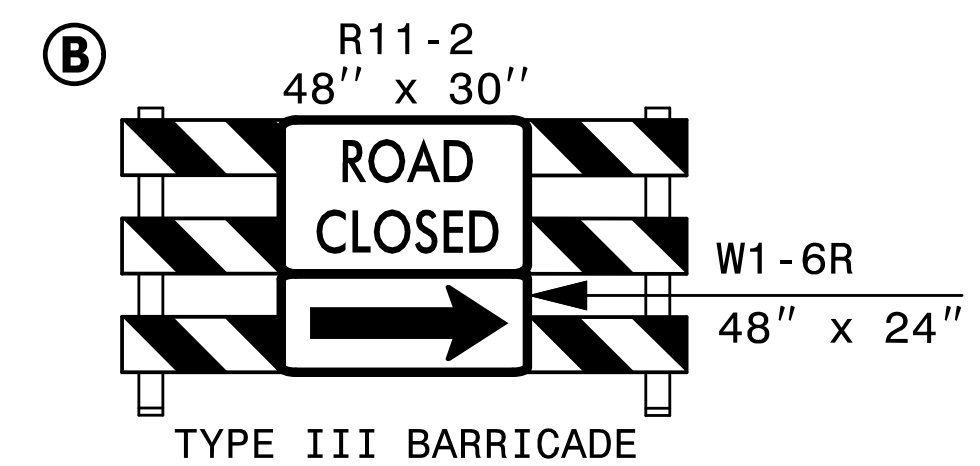
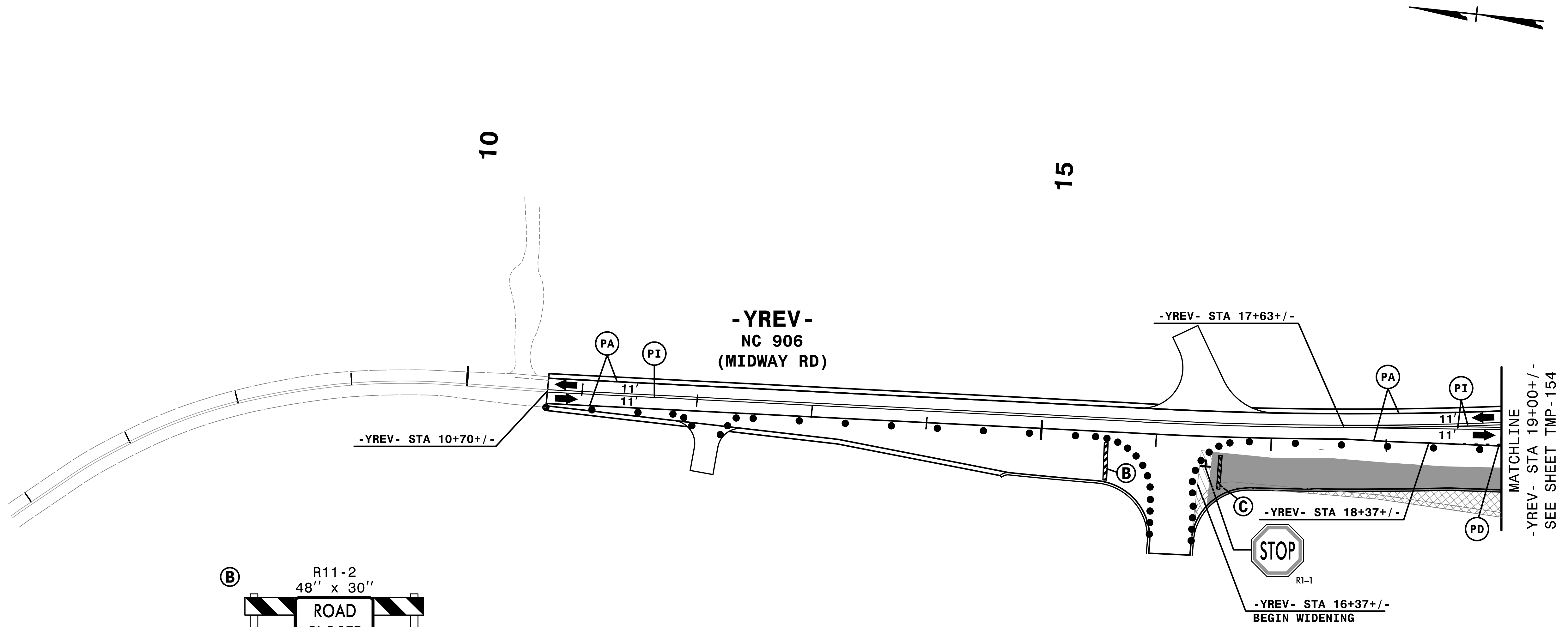

- REMOVE CONFLICTING PAVEMENT MARKING.
- INSTALL APPLICABLE PERMANENT SIGNS.

4:56:08 PM  
 ...\\TCFV-5021\TC\_P3\427.dgn  
 \$\$\$USERNAME\$\$\$

**HNTB** HNTB NORTH CAROLINA, P.C.  
 343 E. Six Forks Road, Suite 200  
 Raleigh, North Carolina 27609  
 NC License No: C-1554

APPROVED: *Helen Shyu*  
 DATE: 9/9/2021

SEAL

DOCUMENT NOT CONSIDERED FINAL  
UNLESS ALL SIGNATURES COMPLETED

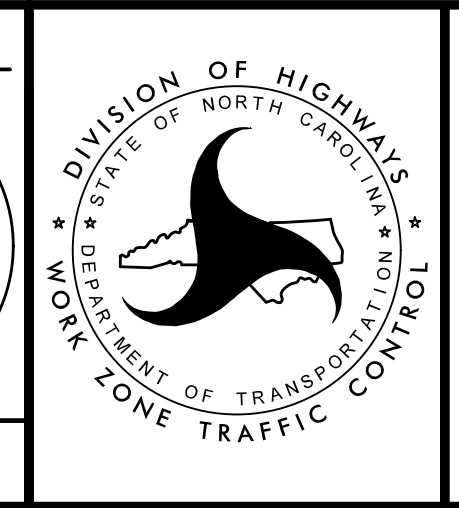

TRANSPORTATION  
MANAGEMENT PLAN

PHASE III  
DETAIL

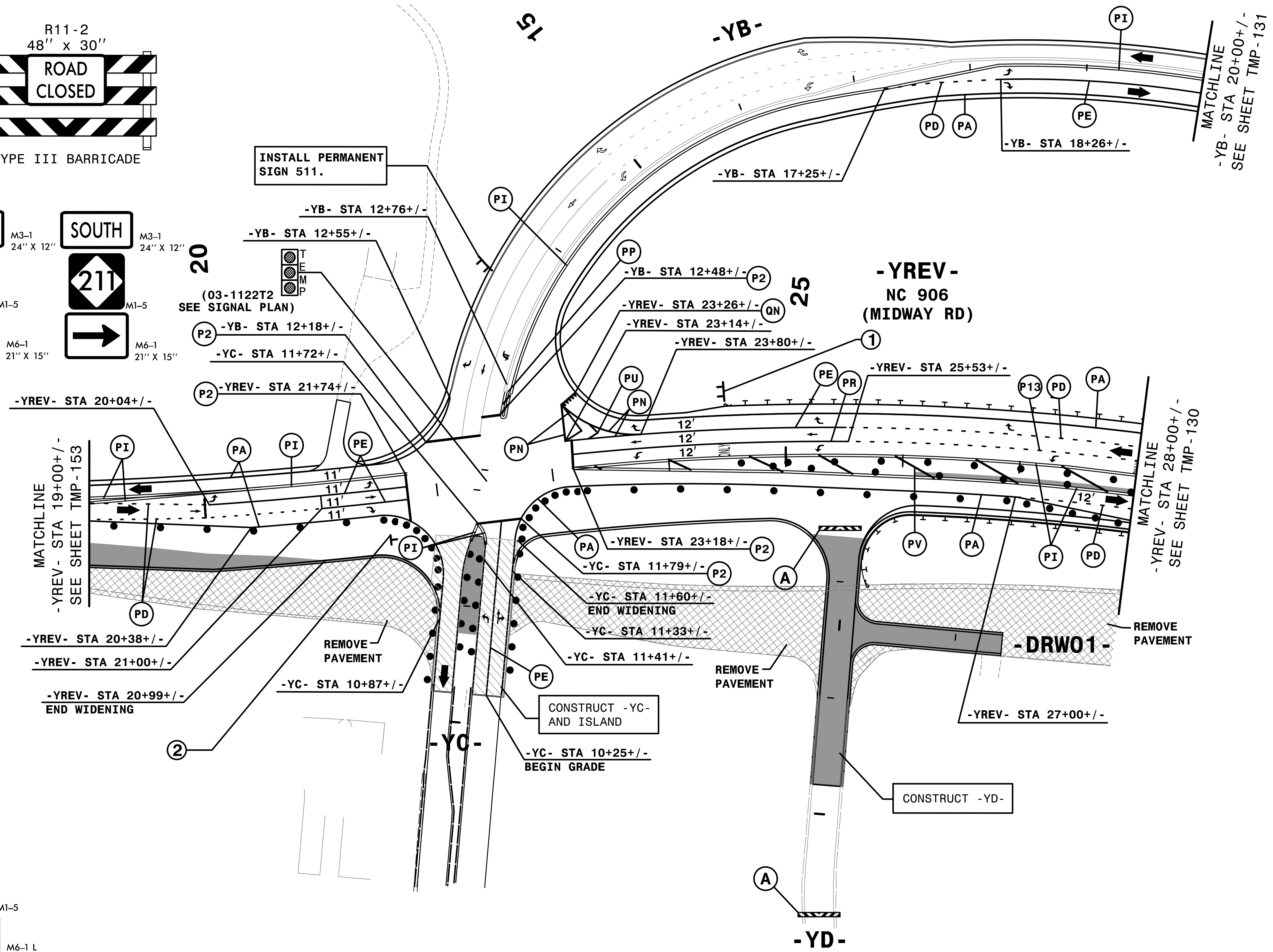
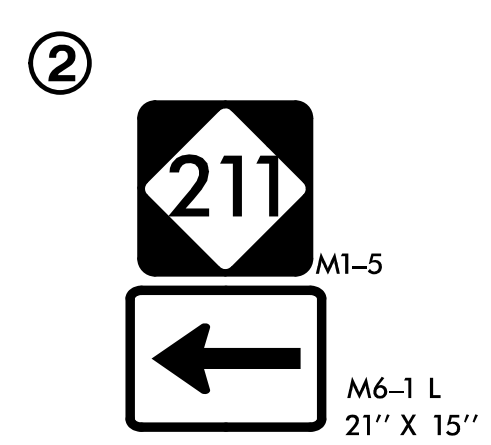
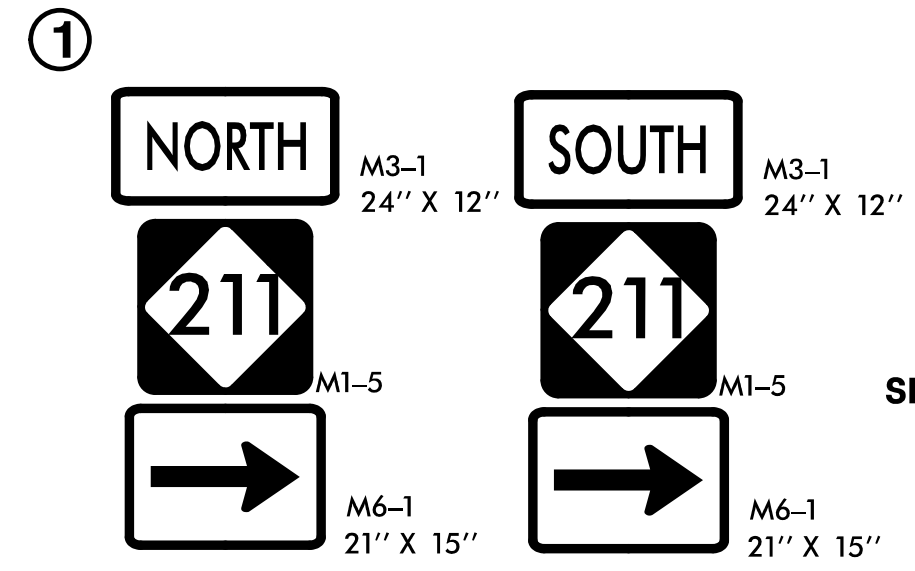
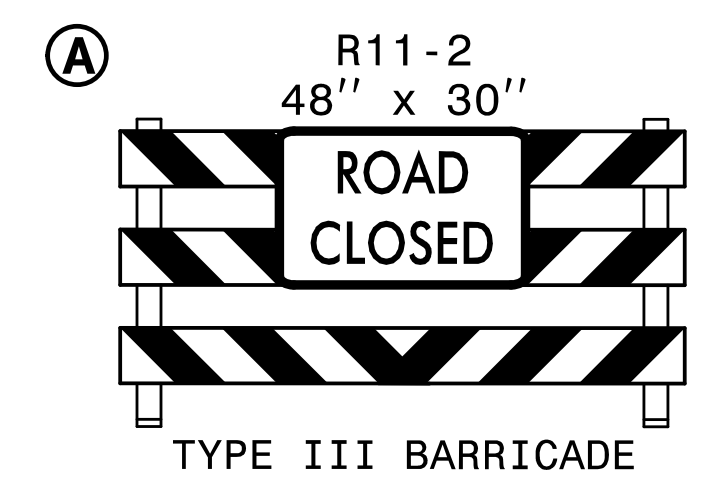

REMOVE CONFLICTING PAVEMENT MARKING.  
INSTALL APPLICABLE PERMANENT SIGNS.

4:41:30 PM  
\\TCFV\5021\10\_p3428.dgn  
\$\$\$\$\$USERNAME\$\$\$\$\$

**HNTB** HNTB NORTH CAROLINA, P.C.  
343 E. Six Forks Road, Suite 200  
Raleigh, North Carolina 27609  
NC License No: C-1554

APPROVED: *Helen Shyu*  
DATE: 9/9/2021  
SEAL  
Professional Engineer  
HELEN SHYU  
042517

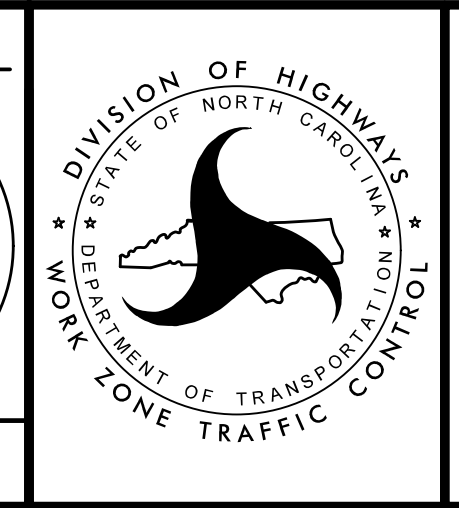

TRANSPORTATION  
MANAGEMENT PLAN  
  
PHASE III  
DETAIL

DOCUMENT NOT CONSIDERED FINAL  
UNLESS ALL SIGNATURES COMPLETED



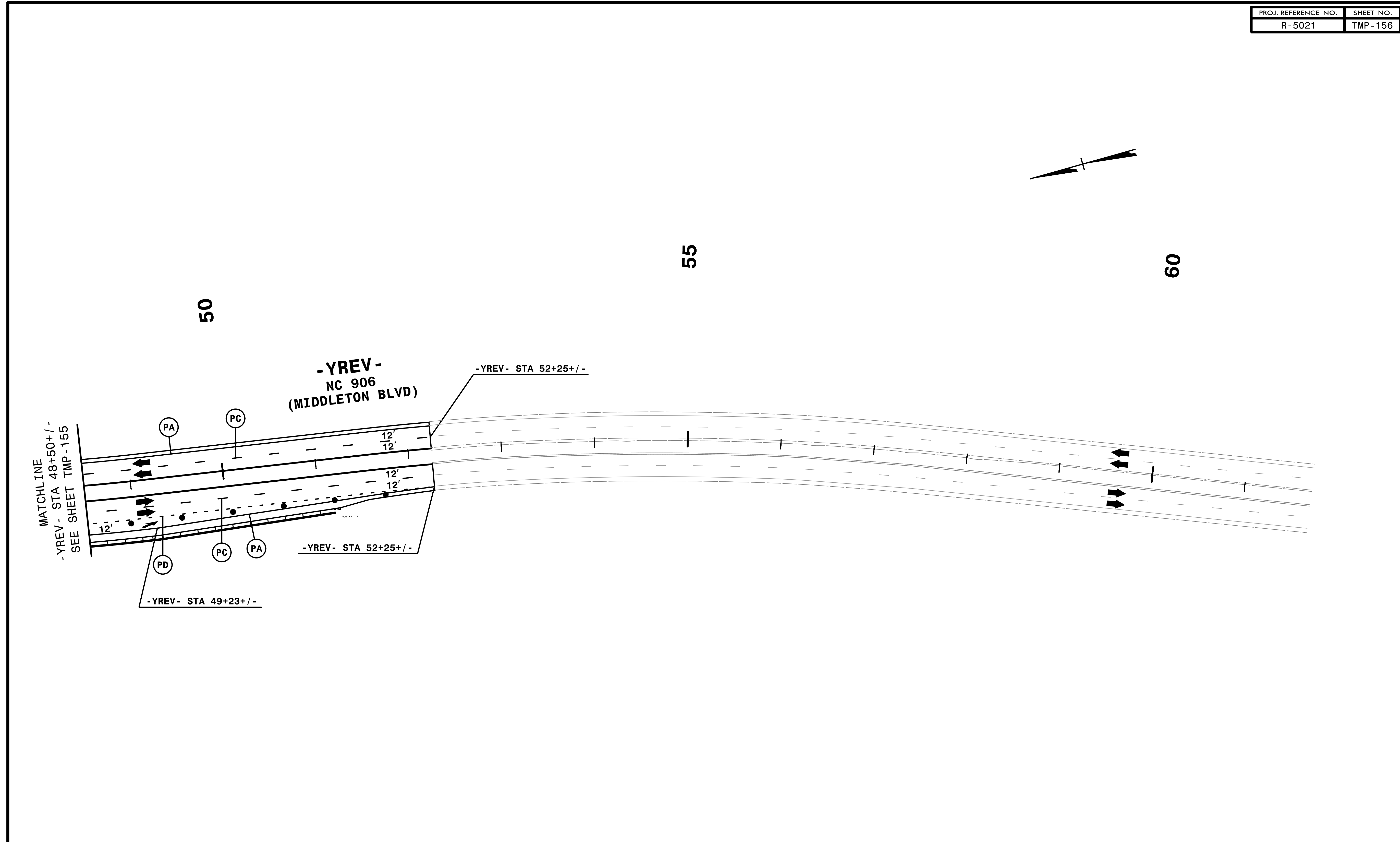

2/6/2019  
 HNTB  
 HNTB

- REMOVE CONFLICTING PAVEMENT MARKING.
- INSTALL APPLICABLE PERMANENT SIGNS.

**HNTB** HNTB NORTH CAROLINA, P.C.  
 343 E. Six Forks Road, Suite 200  
 Raleigh, North Carolina 27609  
 NC License No: C-1554

APPROVED: *Helen Shyu*  
 DATE: 2/6/2019  
 SEAL  
 DOCUMENT NOT CONSIDERED FINAL  
 UNLESS ALL SIGNATURES COMPLETED

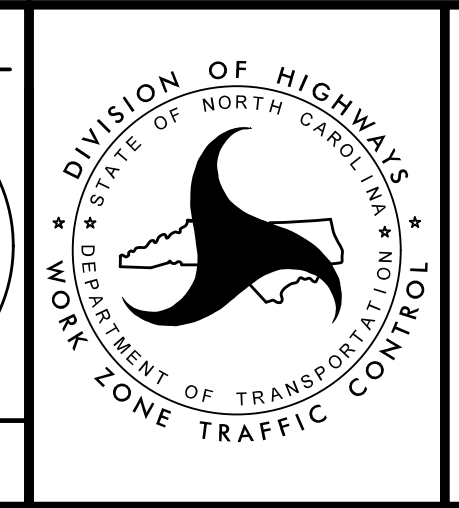

TRANSPORTATION  
 MANAGEMENT PLAN  
 PHASE III  
 DETAIL

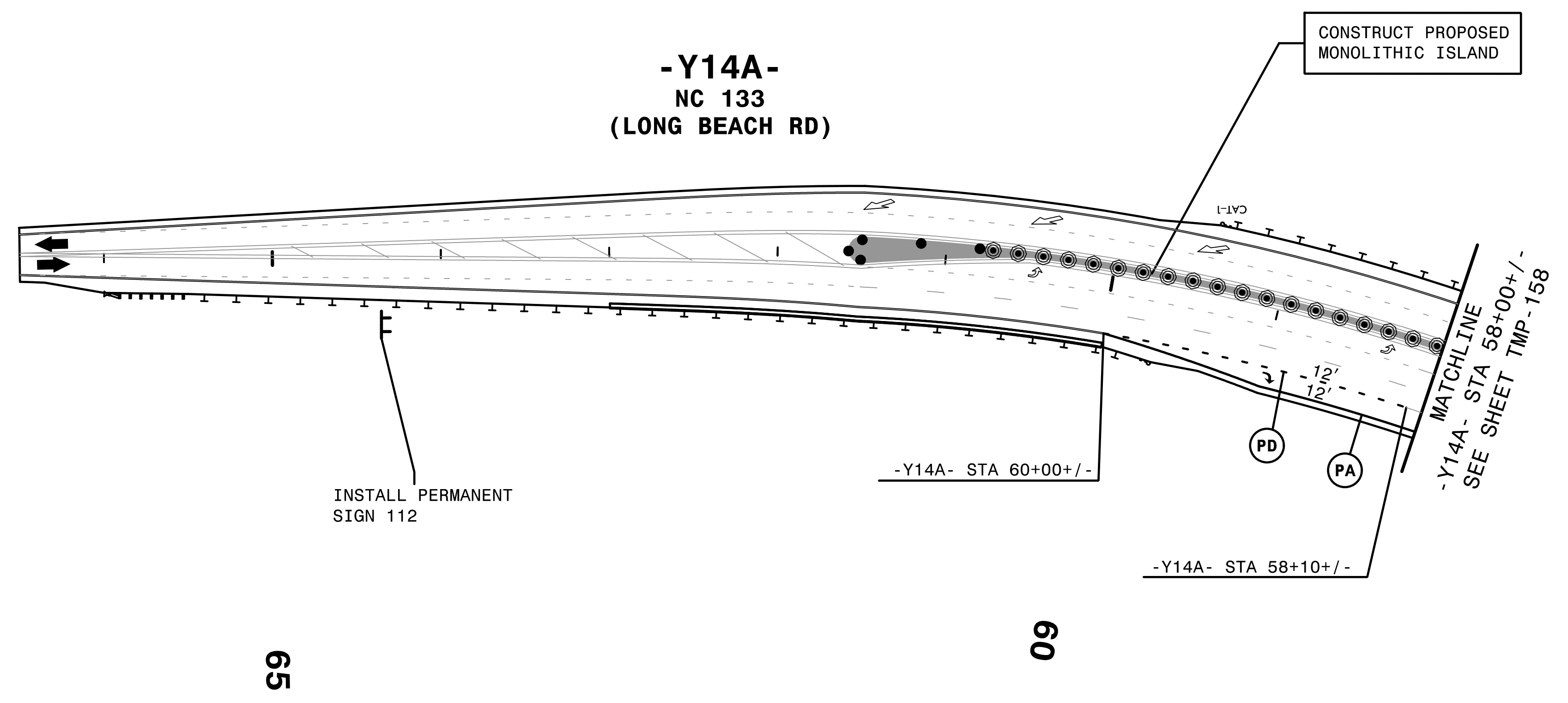
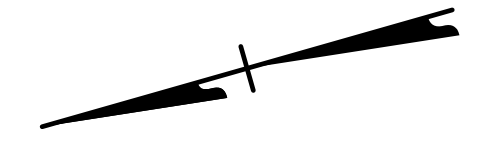

- REMOVE CONFLICTING PAVEMENT MARKING.
- INSTALL APPLICABLE PERMANENT SIGNS.

2/6/2019  
 TCR\5021\to\_p3d32.dgn  
 HNTB

**HNTB** HNTB NORTH CAROLINA, P.C.  
 343 E. Six Forks Road, Suite 200  
 Raleigh, North Carolina 27609  
 NC License No: C-1554

APPROVED: *Helen Shyu*  
 DATE: 2/6/2019  
 SEAL  
 DOCUMENT NOT CONSIDERED FINAL  
 UNLESS ALL SIGNATURES COMPLETED

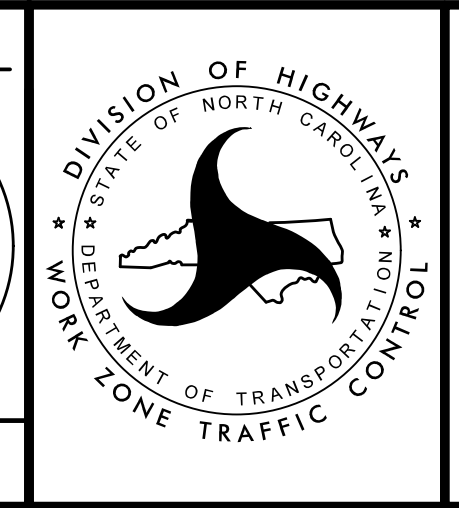

TRANSPORTATION  
 MANAGEMENT PLAN  
 PHASE III  
 DETAIL

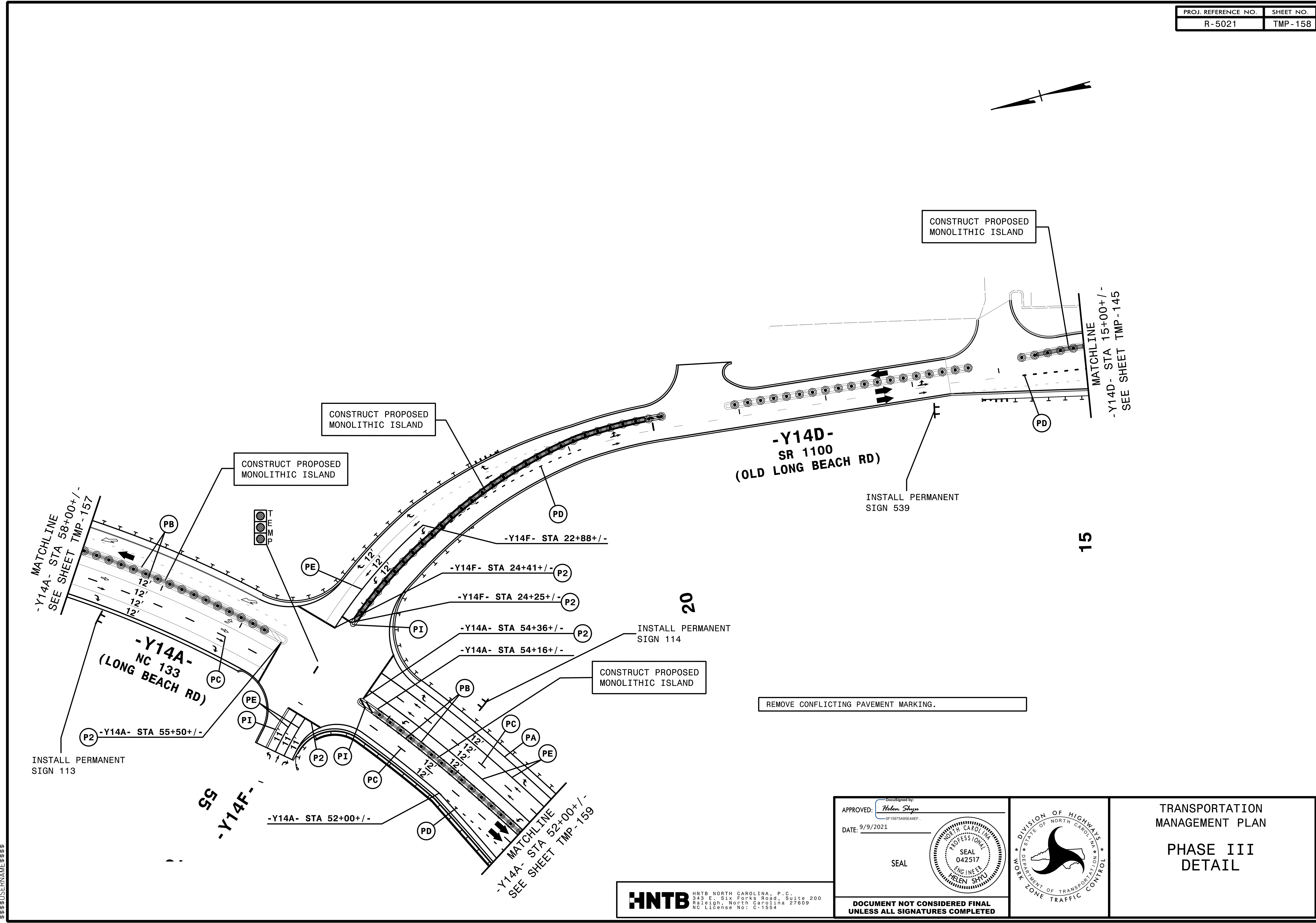

11:51:10 AM  
 \\TCF\5021\10\_p3d35.dgn  
 \$\$\$USERNAME\$\$\$

**HNTB** HNTB NORTH CAROLINA, P.C.  
 343 E. Six Forks Road, Suite 200  
 Raleigh, North Carolina 27609  
 NC License No: C-1554

APPROVED: *Helen Shyu*  
 DATE: 9/9/2021  
 SEAL  
 DOCUMENT NOT CONSIDERED FINAL  
 UNLESS ALL SIGNATURES COMPLETED

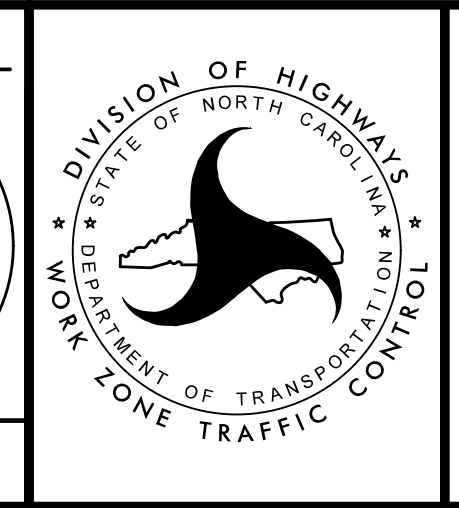

TRANSPORTATION  
 MANAGEMENT PLAN  
 PHASE III  
 DETAIL

15

20

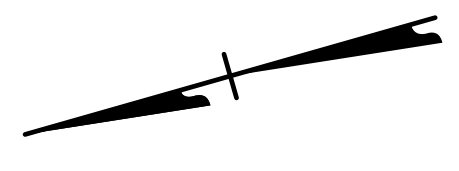
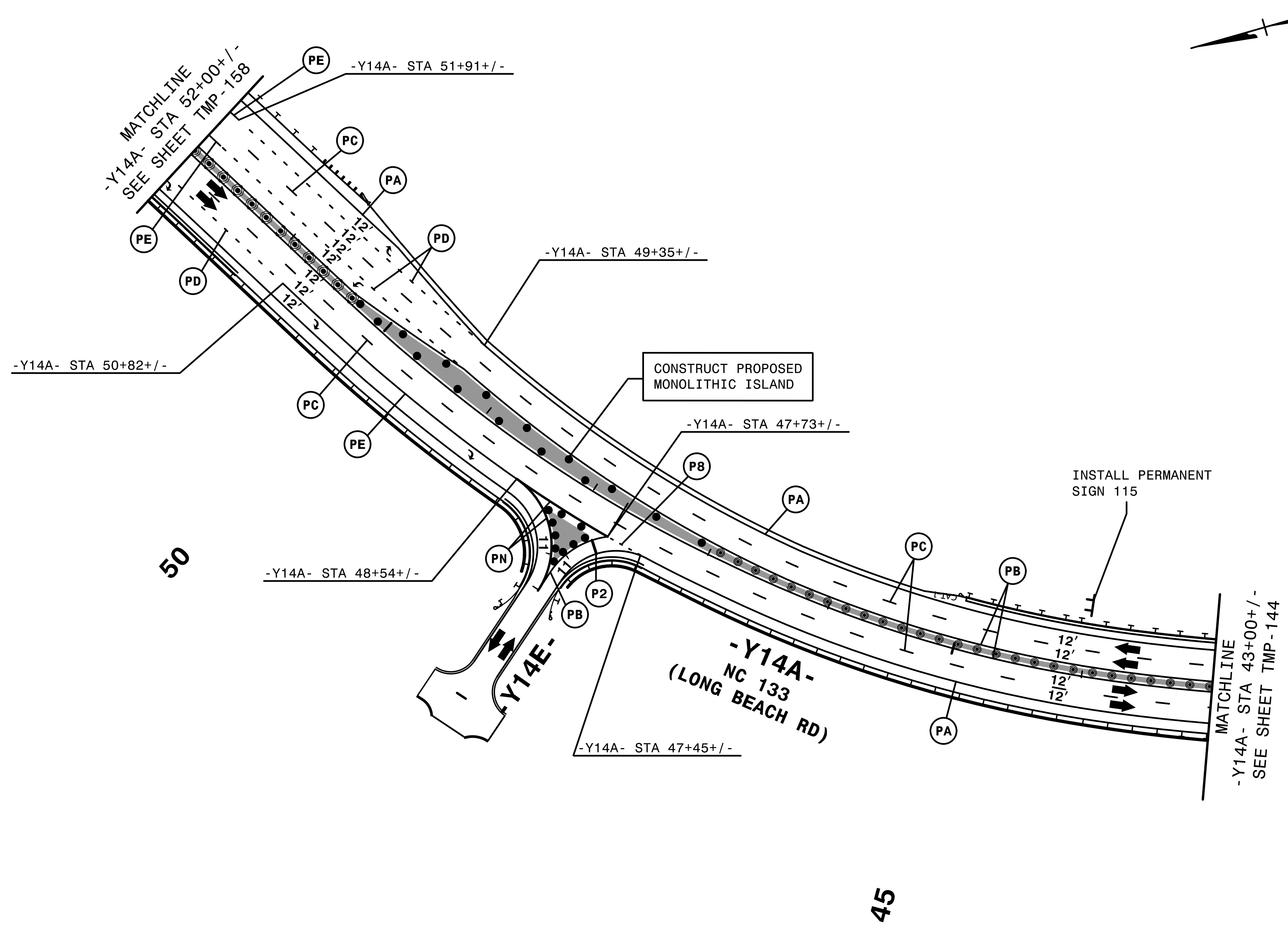

- REMOVE CONFLICTING PAVEMENT MARKING.
- INSTALL APPLICABLE PERMANENT SIGNS.

**HNTB** HNTB NORTH CAROLINA, P.C.  
 343 E. Six Forks Road, Suite 200  
 Raleigh, North Carolina 27609  
 NC License No: C-1554

APPROVED: *Helen Shyu*  
 DATE: 9/9/2021  
 SEAL  
 DOCUMENT NOT CONSIDERED FINAL  
 UNLESS ALL SIGNATURES COMPLETED

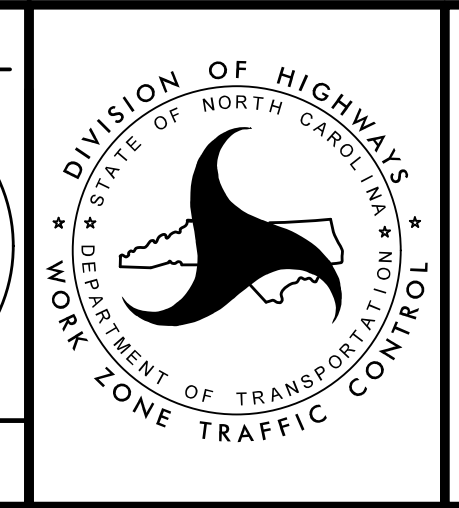
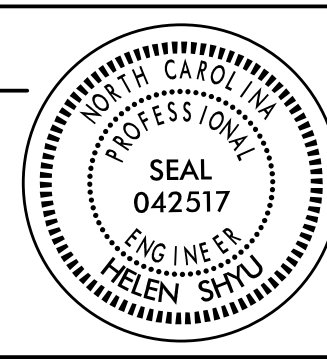

TRANSPORTATION  
 MANAGEMENT PLAN  
 PHASE III  
 DETAIL

4:56:17 PM  
 \\TCF\15021\10\_p3d33.dgn  
 \$\$\$USERNAME\$\$\$



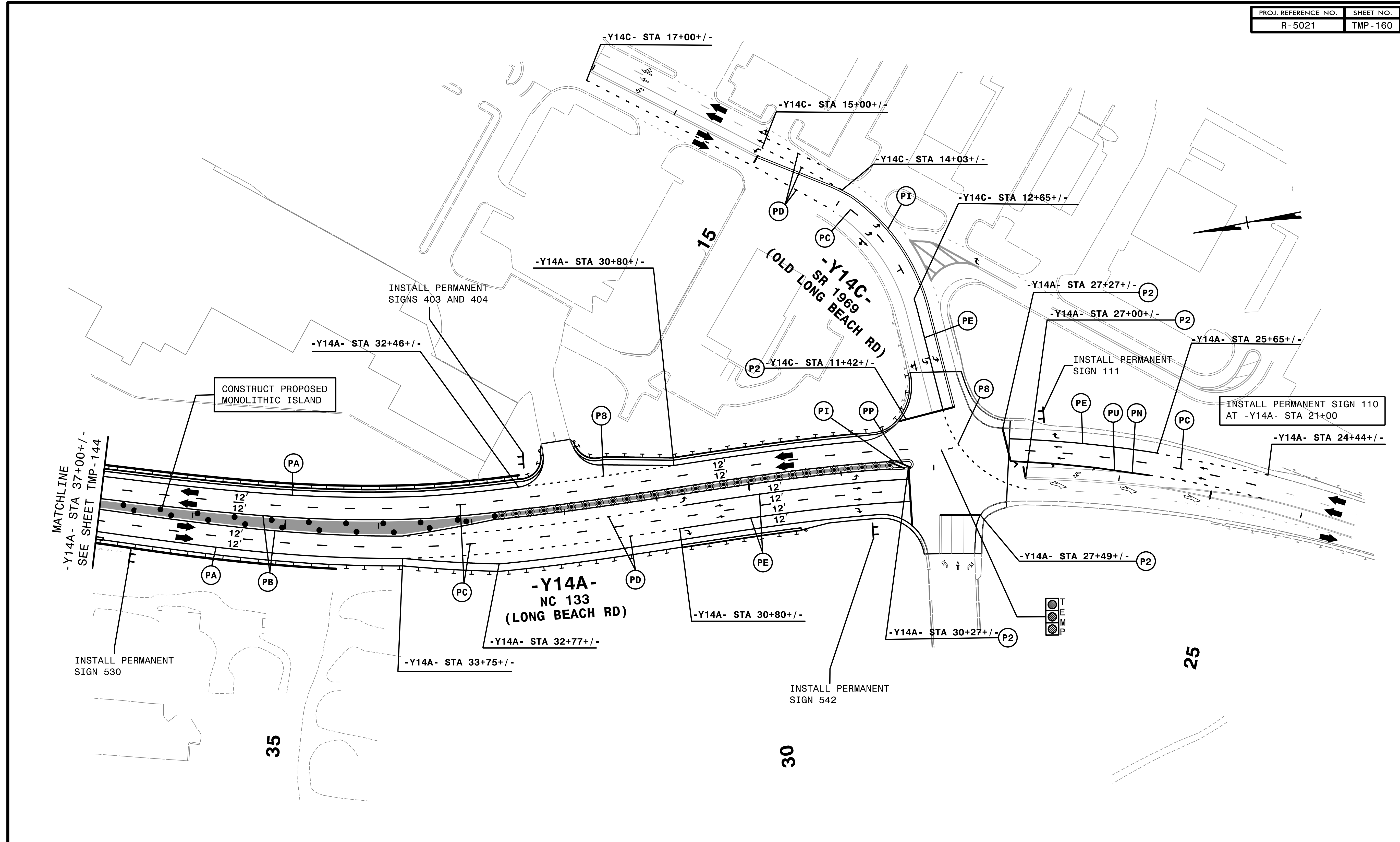

4/14/22 PM  
 \\TCF\5021\10\p3\34.dgn  
 \$\$\$USERNAME\$\$\$

REMOVE CONFLICTING PAVEMENT MARKING.

INSTALL APPLICABLE PERMANENT SIGNS.

**HNTB** HNTB NORTH CAROLINA, P.C.  
 343 E. Six Forks Road, Suite 200  
 Raleigh, North Carolina 27609  
 NC License No: C-1554

APPROVED: *Helen Shyu*  
 DATE: 9/9/2021

SEAL

DOCUMENT NOT CONSIDERED FINAL  
 UNLESS ALL SIGNATURES COMPLETED

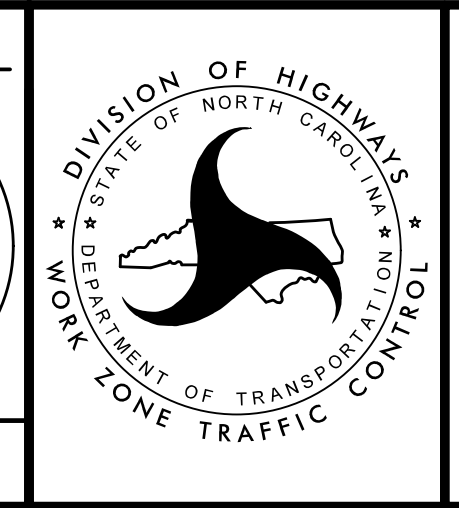

TRANSPORTATION  
 MANAGEMENT PLAN

PHASE III  
 DETAIL

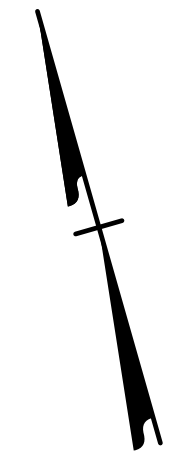
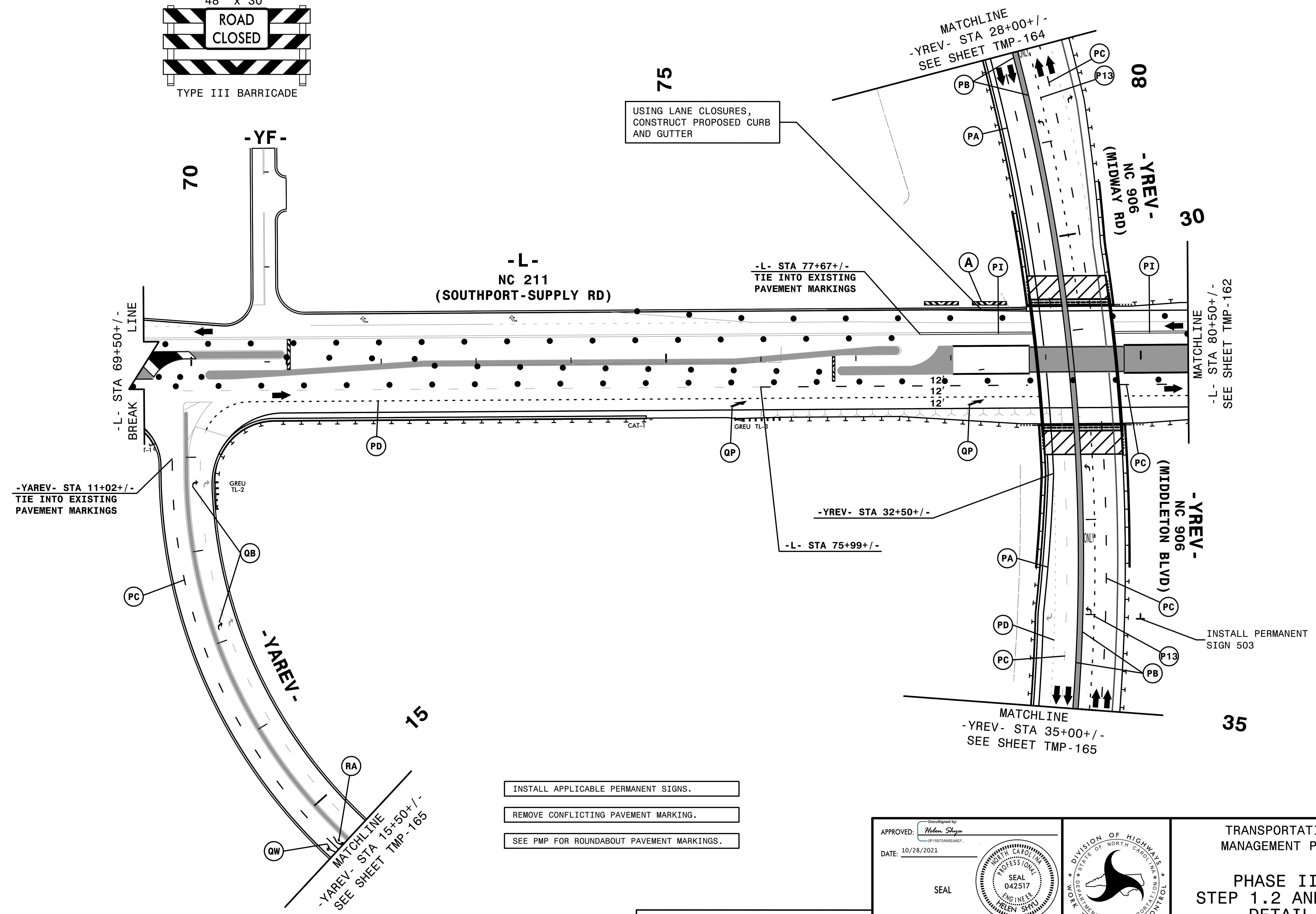
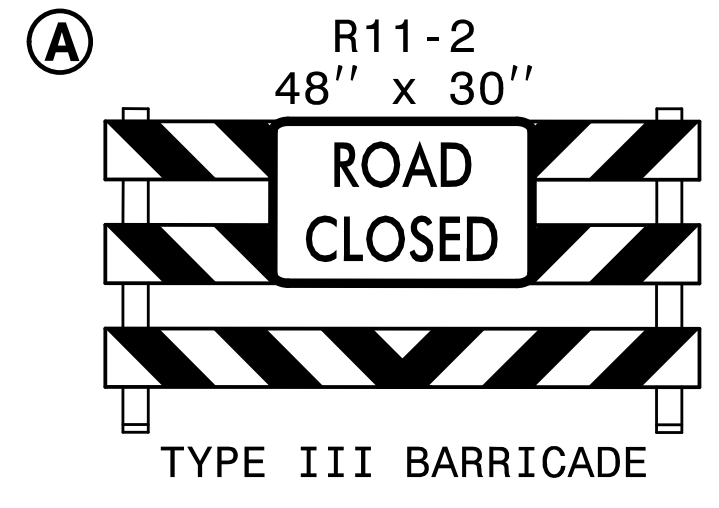

3:24:23 PM  
\\TCPLV5021\fc\_dp3d3 GreenT.dgn  
\$\$\$\$\$USERNAME\$\$\$\$\$

**HNTB**  
HNTB NORTH CAROLINA, P.C.  
343 E. Six Forks Road, Suite 200  
Raleigh, North Carolina 27609  
NC License No: C-1554

APPROVED: *Helen Shyu*  
DATE: 10/28/2021

SEAL

PROFESSIONAL ENGINEER  
HELEN SHYU  
042517

DOCUMENT NOT CONSIDERED FINAL  
UNLESS ALL SIGNATURES COMPLETED

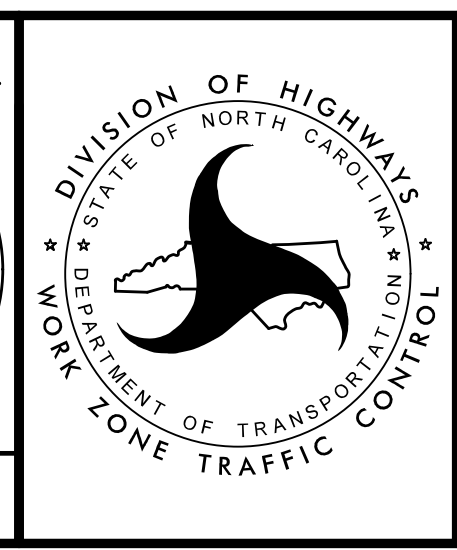

TRANSPORTATION  
MANAGEMENT PLAN

PHASE III  
STEP 1.2 AND 1.3  
DETAIL

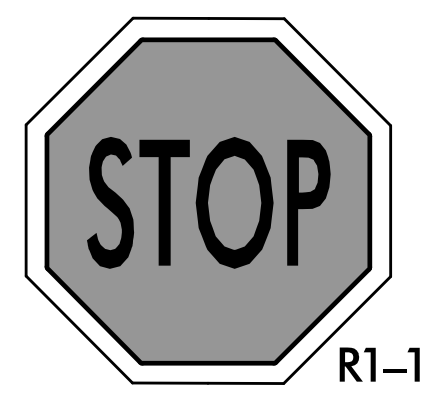
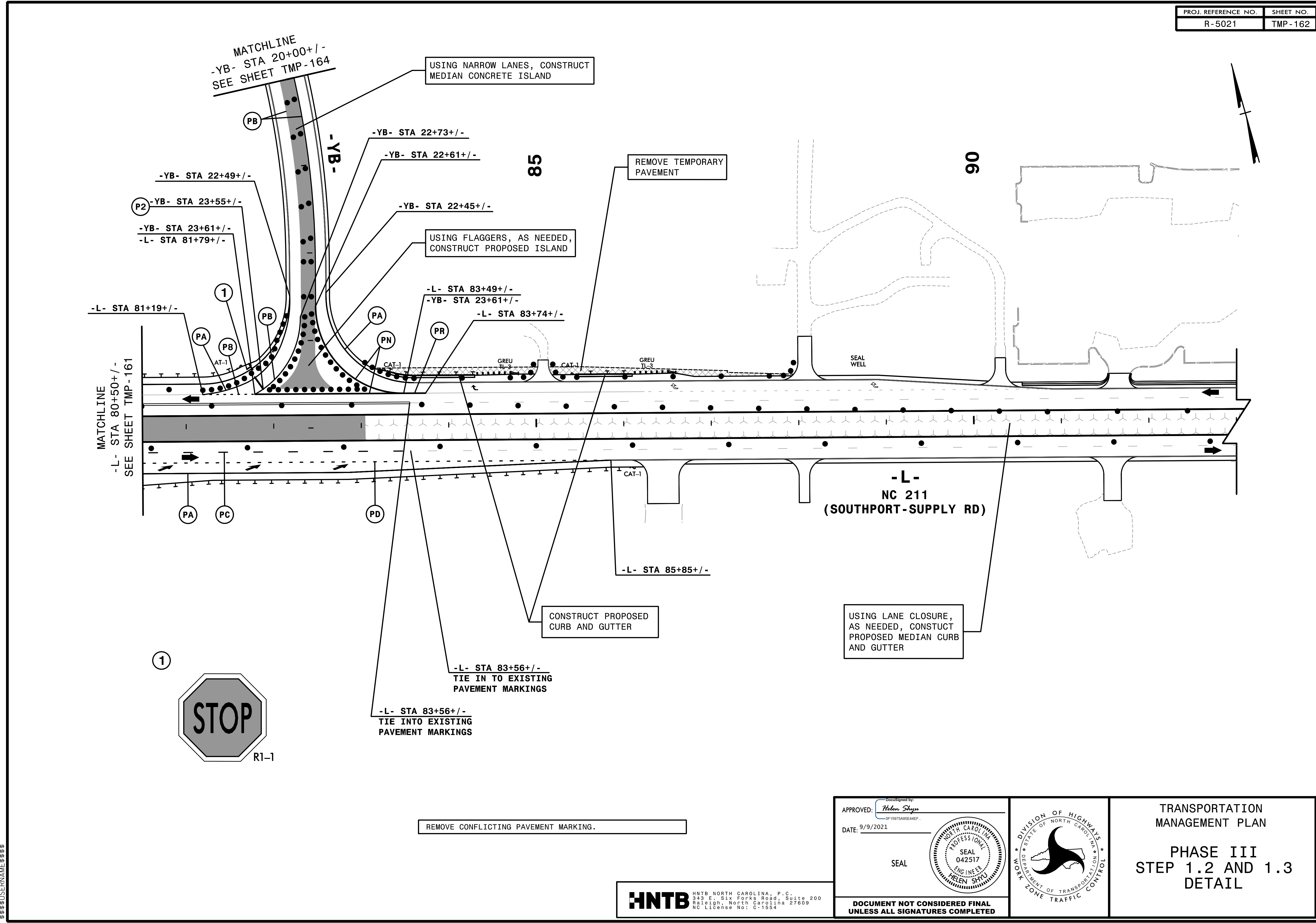

4:56:24 PM  
 ...NCPV\5021\TC\_p3d4 GreenT.dgn  
 \$\$\$USERNAME\$\$\$

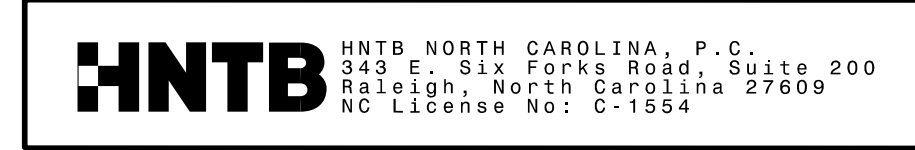

APPROVED: *Helen Shyu*  
 DATE: 9/9/2021  
 SEAL  
 DOCUMENT NOT CONSIDERED FINAL  
 UNLESS ALL SIGNATURES COMPLETED

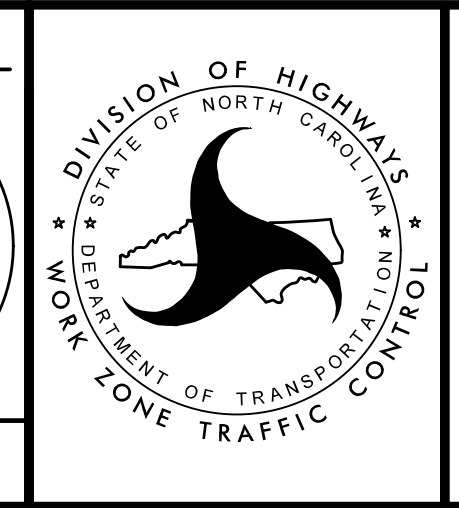

TRANSPORTATION  
 MANAGEMENT PLAN  
 PHASE III  
 STEP 1.2 AND 1.3  
 DETAIL

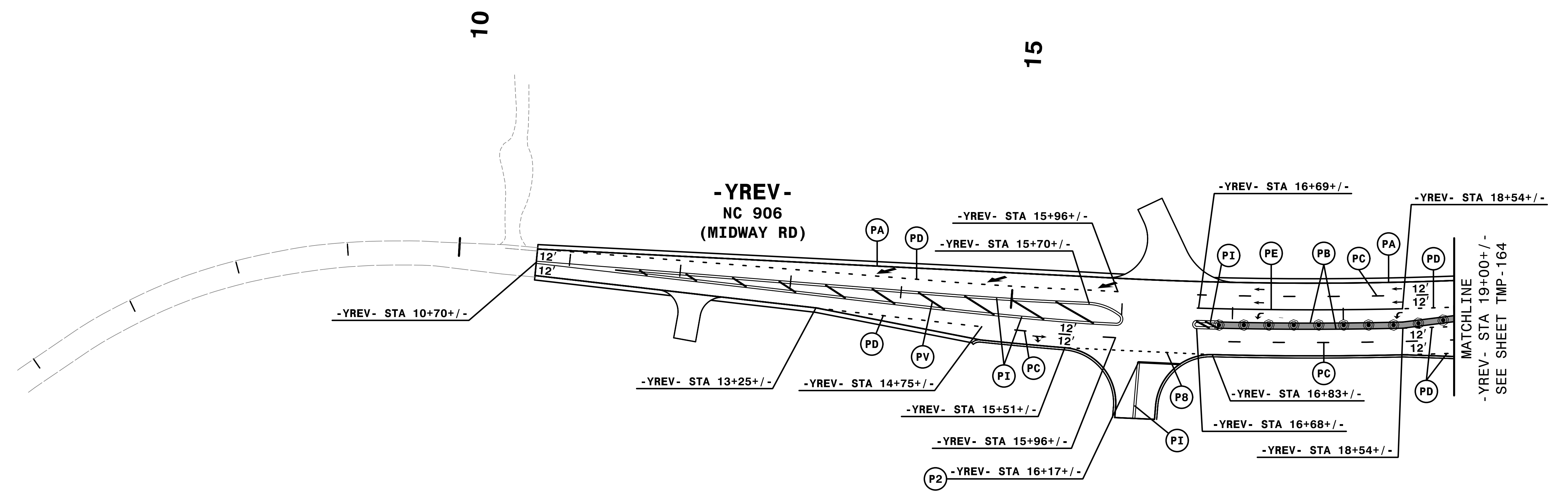

REMOVE CONFLICTING PAVEMENT MARKING.

4:56:26 PM  
...\\TCF\...5021\...p3d27 GreenT.dgn  
\$\$\$\$\$USERNAME\$\$\$\$\$

**HNTB** HNTB NORTH CAROLINA, P.C.  
343 E. Six Forks Road, Suite 200  
Raleigh, North Carolina 27609  
NC License No: C-1554

APPROVED: *Helen Shyu*  
DATE: 9/9/2021  
SEAL  
DOCUMENT NOT CONSIDERED FINAL  
UNLESS ALL SIGNATURES COMPLETED

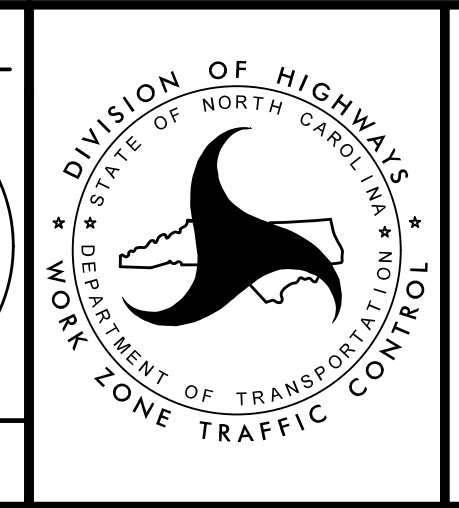
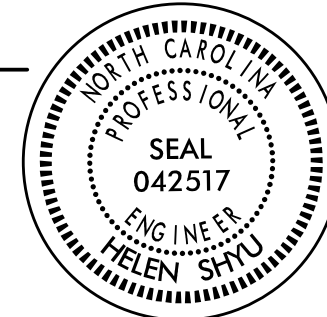

TRANSPORTATION  
MANAGEMENT PLAN  
  
PHASE III  
STEPS 1.2 AND 1.3  
DETAIL

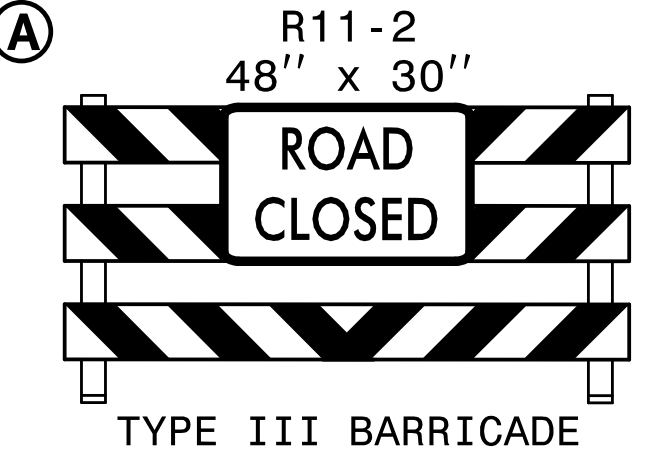
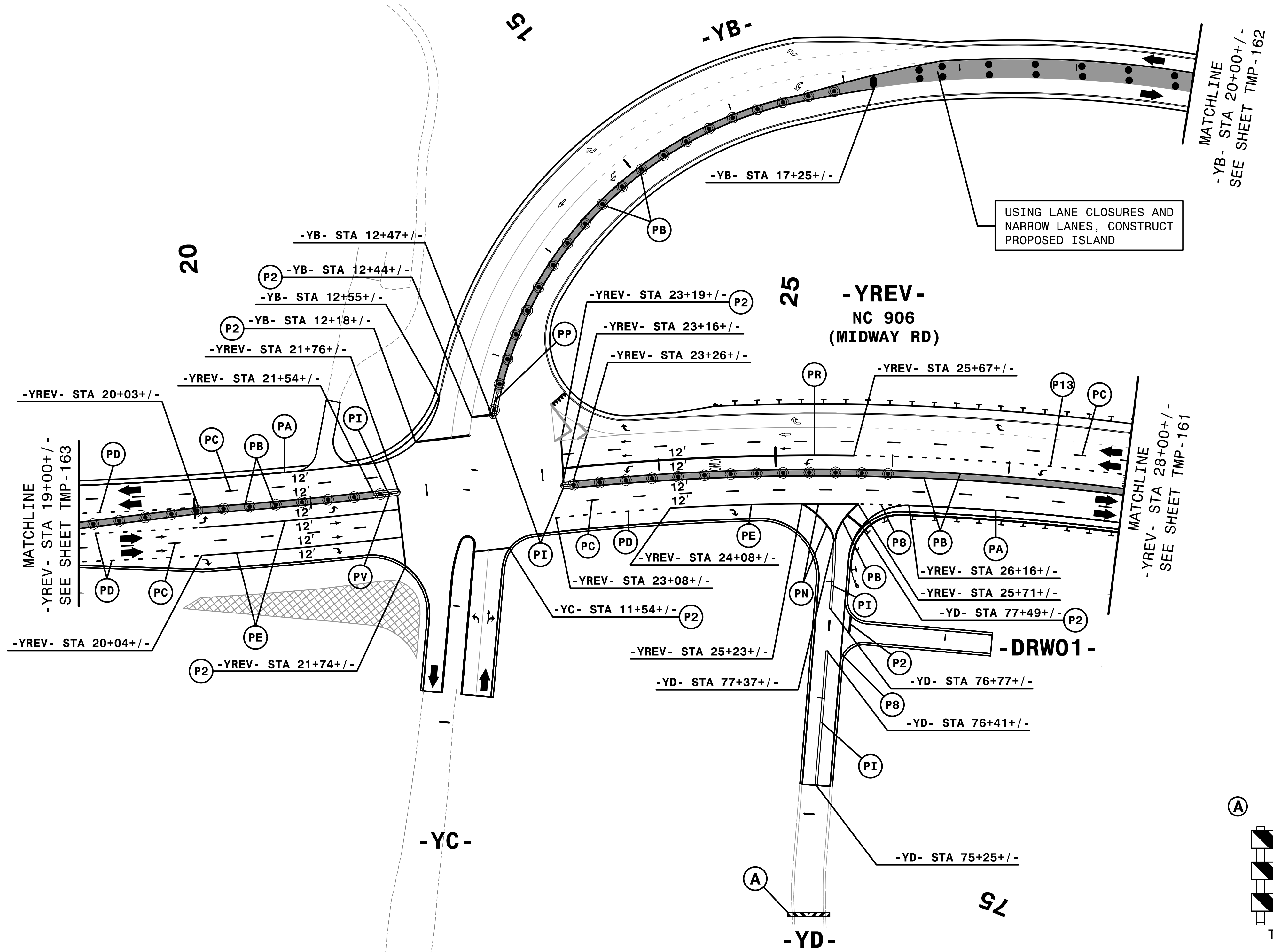

REMOVE CONFLICTING PAVEMENT MARKING.

11:51:24 AM  
...TCF...5021...p3d28 GreenT.dgn  
\$\$\$\$\$USERNAME\$\$\$\$\$

**HNTB** HNTB NORTH CAROLINA, P.C.  
343 E. Six Forks Road, Suite 200  
Raleigh, North Carolina 27609  
NC License No: C-1554

APPROVED: *Helen Shyu*  
DATE: 9/9/2021  
SEAL  
DOCUMENT NOT CONSIDERED FINAL  
UNLESS ALL SIGNATURES COMPLETED

DIVISION OF HIGHWAYS  
STATE OF NORTH CAROLINA  
DEPARTMENT OF TRANSPORTATION  
WORK ZONE TRAFFIC CONTROL

TRANSPORTATION  
MANAGEMENT PLAN  
PHASE III  
STEPS 1.2 AND 1.3  
DETAIL

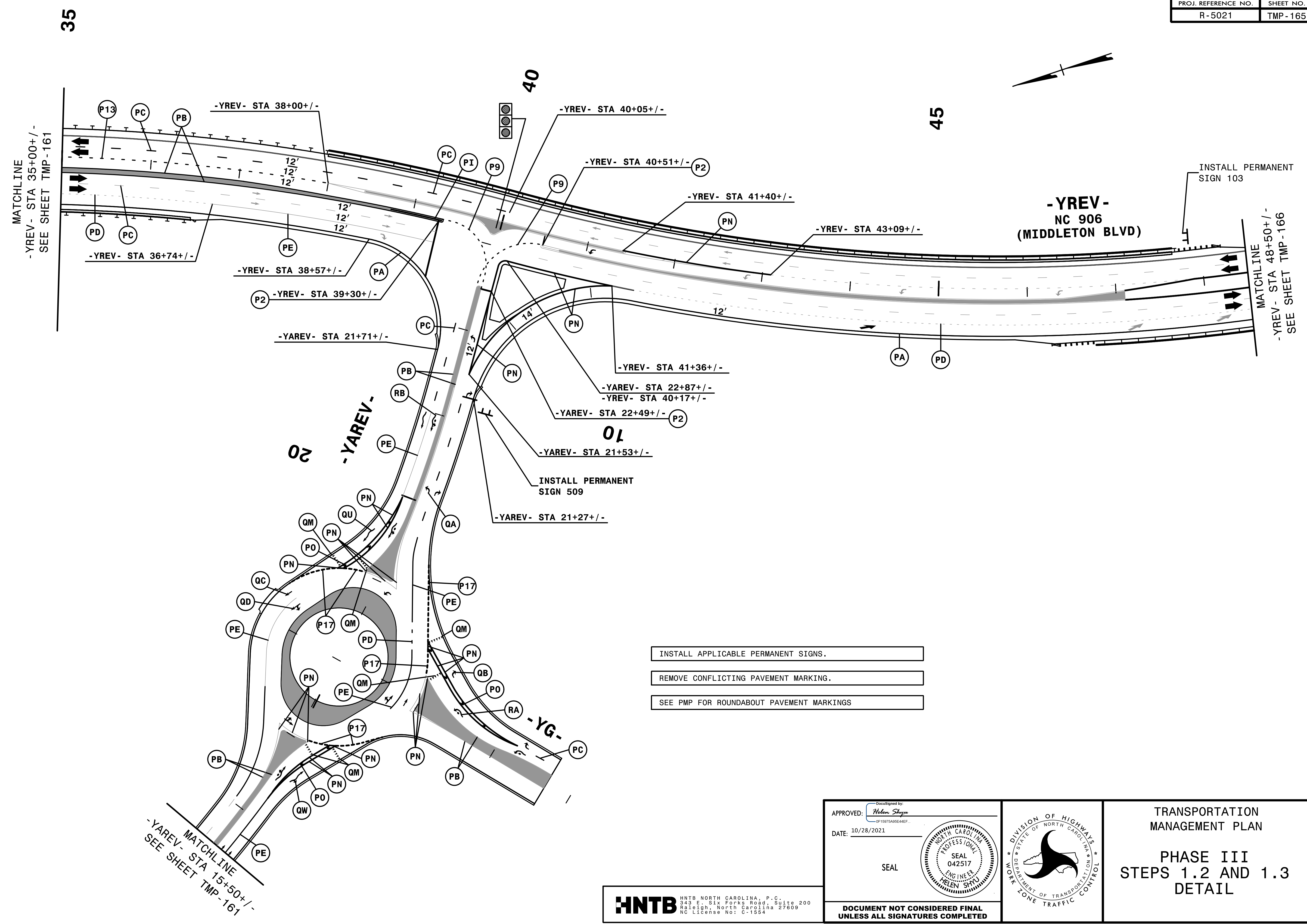

35  
MATCHLINE  
-YREV- STA 35+00+/-  
SEE SHEET TMP-161

-YREV- STA 36+74+/-  
-YREV- STA 38+00+/-  
-YREV- STA 38+57+/-  
-YREV- STA 39+30+/-

-YAREV- STA 21+71+/-

40  
-YREV- STA 40+05+/-

-YREV- STA 40+51+/-  
-YREV- STA 41+40+/-

-YREV- STA 43+09+/-

45  
-YREV- NC 906 (MIDDLETON BLVD)

MATCHLINE  
-YREV- STA 48+50+/-  
SEE SHEET TMP-166

20  
-YAREV-

-YAREV- STA 21+53+/-  
-YAREV- STA 21+27+/-  
-YAREV- STA 22+87+/-  
-YAREV- STA 40+17+/-  
-YAREV- STA 22+49+/-

INSTALL PERMANENT SIGN 509

- INSTALL APPLICABLE PERMANENT SIGNS.
- REMOVE CONFLICTING PAVEMENT MARKING.
- SEE PMP FOR ROUNDABOUT PAVEMENT MARKINGS

3:24:26 PM  
TCPLR5021.fc\_p3d29 GreenT.dgn  
\$\$\$\$\$USERNAME\$\$\$\$\$

MATCHLINE  
-YAREV- STA 15+50+/-  
SEE SHEET TMP-161

**HNTB**  
HNTB NORTH CAROLINA, P.C.  
343 E. Six Forks Road, Suite 200  
Raleigh, North Carolina 27609  
NC License No: C-1554

APPROVED: *Helen Shyu*  
DATE: 10/28/2021  
SEAL  
DOCUMENT NOT CONSIDERED FINAL  
UNLESS ALL SIGNATURES COMPLETED

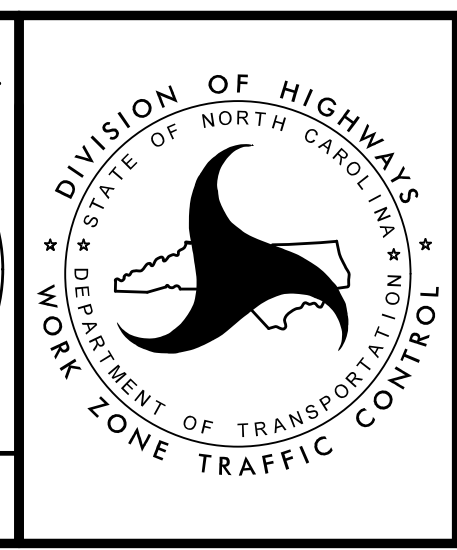

TRANSPORTATION  
MANAGEMENT PLAN  
  
PHASE III  
STEPS 1.2 AND 1.3  
DETAIL

PROJ. REFERENCE NO.	SHEET NO.
R-5021	TMP-166

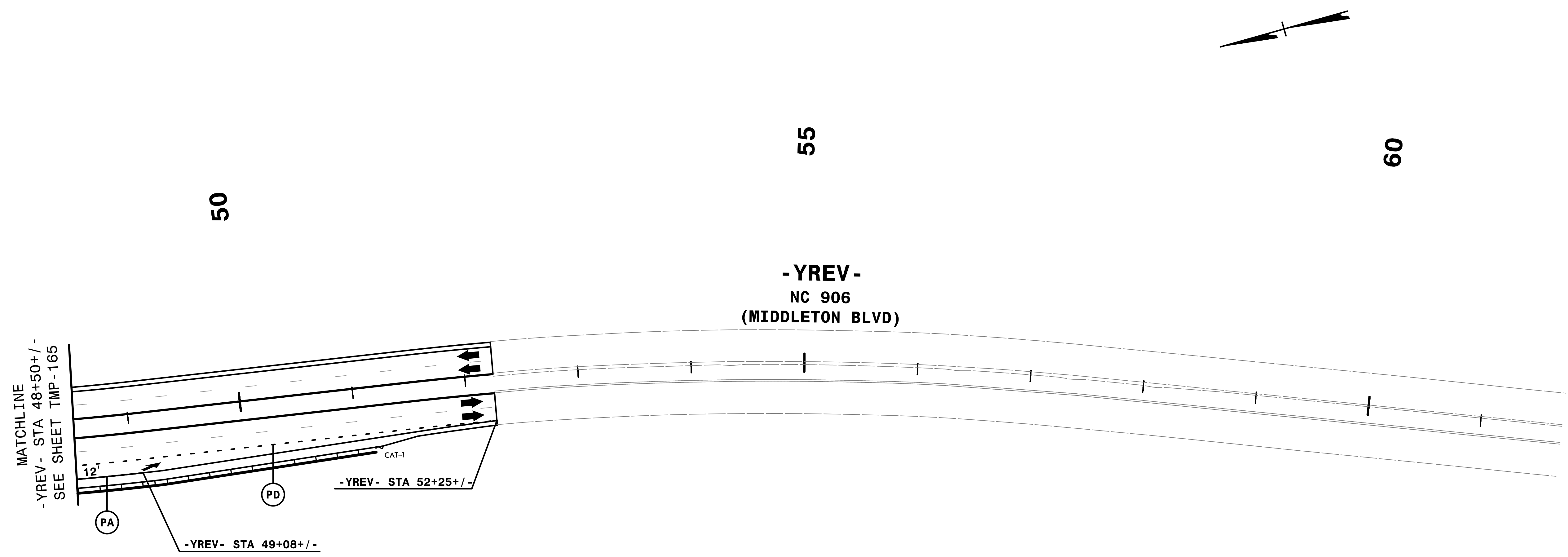

REMOVE CONFLICTING PAVEMENT MARKING.

2/6/2019  
 T:\CP\5021\to.p3d30 GreenT.dgn  
 HNTB

**HNTB** HNTB NORTH CAROLINA, P.C.  
 343 E. Six Forks Road, Suite 200  
 Raleigh, North Carolina 27609  
 NC License No: C-1554

APPROVED: *Helen Shyu*  
 DATE: 2/6/2019  
 SEAL  
 DOCUMENT NOT CONSIDERED FINAL  
 UNLESS ALL SIGNATURES COMPLETED

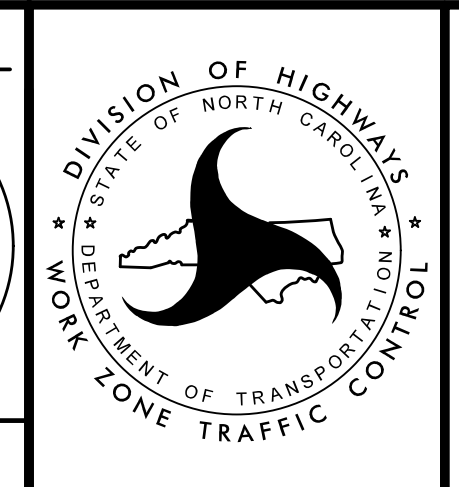

TRANSPORTATION  
 MANAGEMENT PLAN  
 PHASE III  
 STEPS 1.2 AND 1.3  
 DETAIL