

PROJ. REFERENCE NO.	SHEET NO.
R-5021	TMP-18

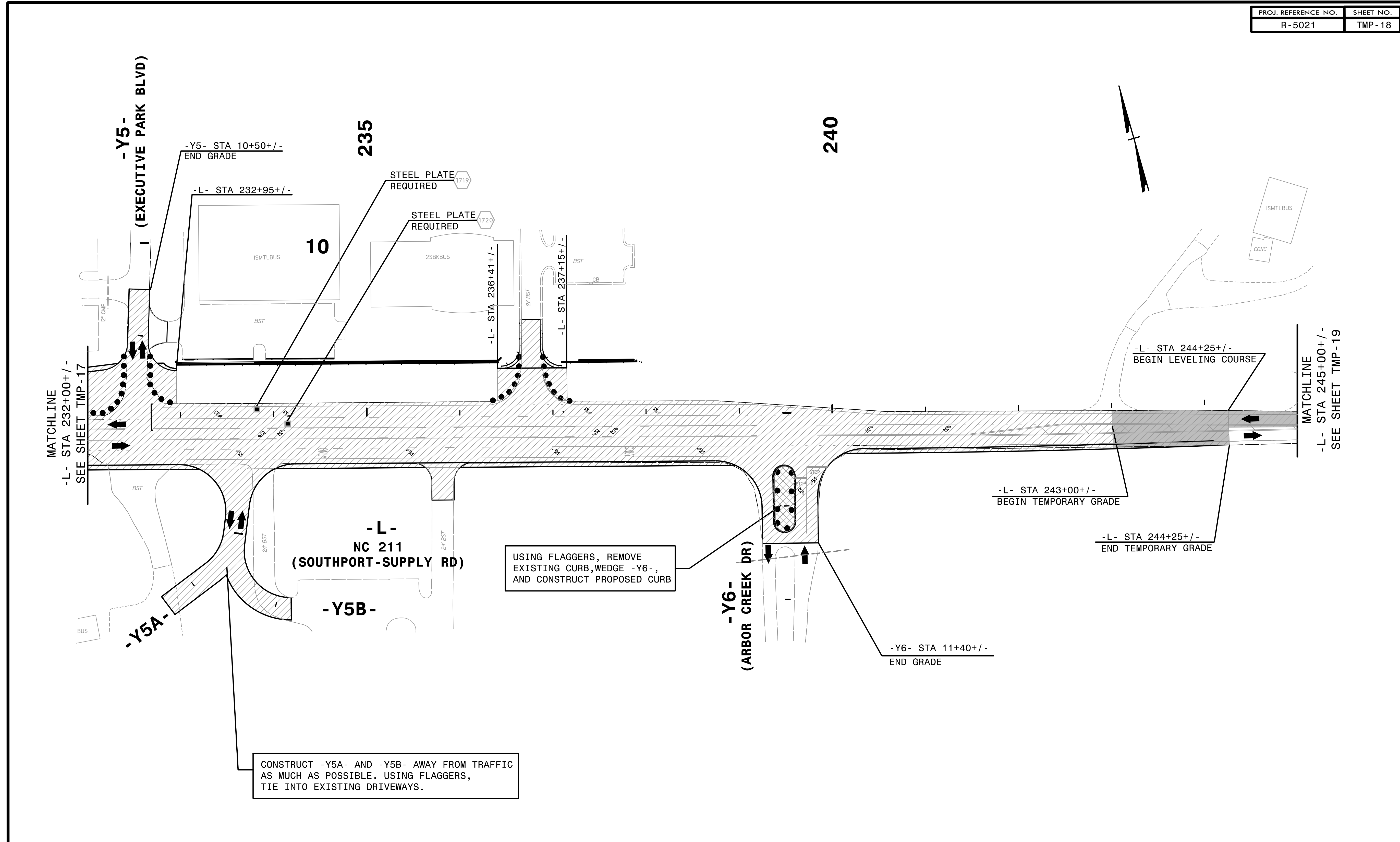

2/6/2019  
TCPLV-5021.tc\_pidll.dgn  
HNTB

**HNTB** HNTB NORTH CAROLINA, P.C.  
343 E. Six Forks Road, Suite 200  
Raleigh, North Carolina 27609  
NC License No: C-1554

APPROVED: *Helen Skyy*  
DATE: 2/6/2019  
SEAL  
PROFESSIONAL SEAL  
042517  
ENGINEER  
HELEN SKYY

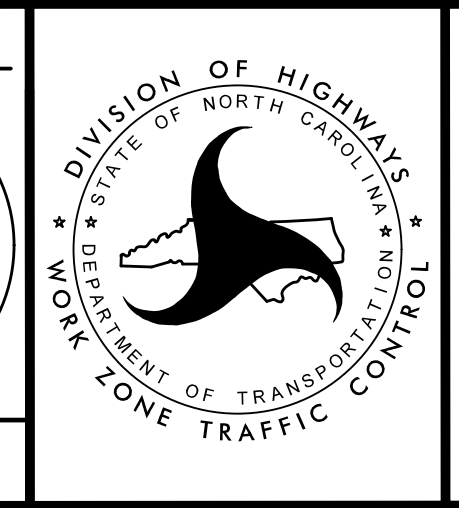

TRANSPORTATION  
MANAGEMENT PLAN

PHASE I  
DETAIL

DOCUMENT NOT CONSIDERED FINAL  
UNLESS ALL SIGNATURES COMPLETED

PROJ. REFERENCE NO.	SHEET NO.
R-5021	TMP - 19

245

250

255

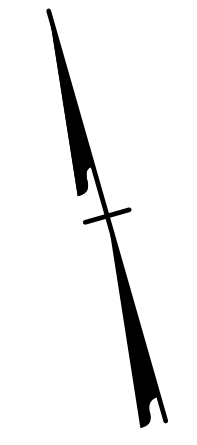

MATCHLINE  
-L- STA 245+00+/-  
SEE SHEET TMP-18

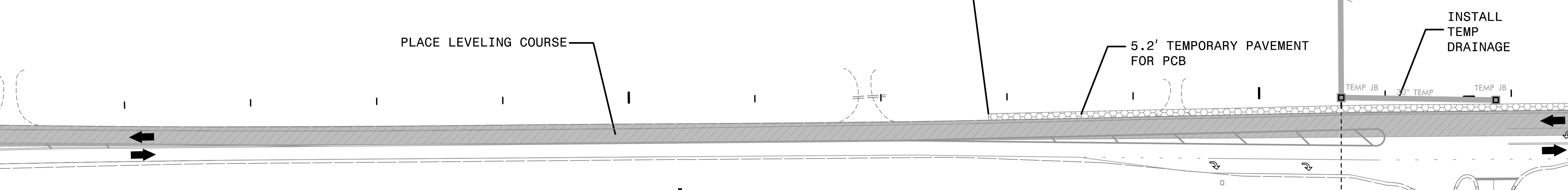

-L- STA 252+85+/-  
BEGIN TEMPORARY  
PAVEMENT  
10.8' RT

PLACE LEVELING COURSE

5.2' TEMPORARY PAVEMENT  
FOR PCB

INSTALL  
TEMP  
DRAINAGE

MATCHLINE  
-L- STA 257+50+/-  
SEE SHEET TMP-20

-L-  
NC 211  
(SOUTHPORT-SUPPLY RD)

-Y7-  
(REGENCY CROSSING)

REPLACE PAVEMENT MARKINGS IN EXISTING PATTERN.

2/6/2019  
HNTB

**HNTB** HNTB NORTH CAROLINA, P.C.  
343 E. Six Forks Road, Suite 200  
Raleigh, North Carolina 27609  
NC License No: C-1554

APPROVED: *Helen Skyy*  
DATE: 2/6/2019  
SEAL  
PROFESSIONAL ENGINEER  
HELEN SKYY  
042517

DIVISION OF HIGHWAYS  
STATE OF NORTH CAROLINA  
DEPARTMENT OF TRANSPORTATION  
WORK ZONE TRAFFIC CONTROL

TRANSPORTATION  
MANAGEMENT PLAN  
  
PHASE I  
DETAIL

DOCUMENT NOT CONSIDERED FINAL  
UNLESS ALL SIGNATURES COMPLETED



PROJ. REFERENCE NO.	SHEET NO.
R-5021	TMP-21

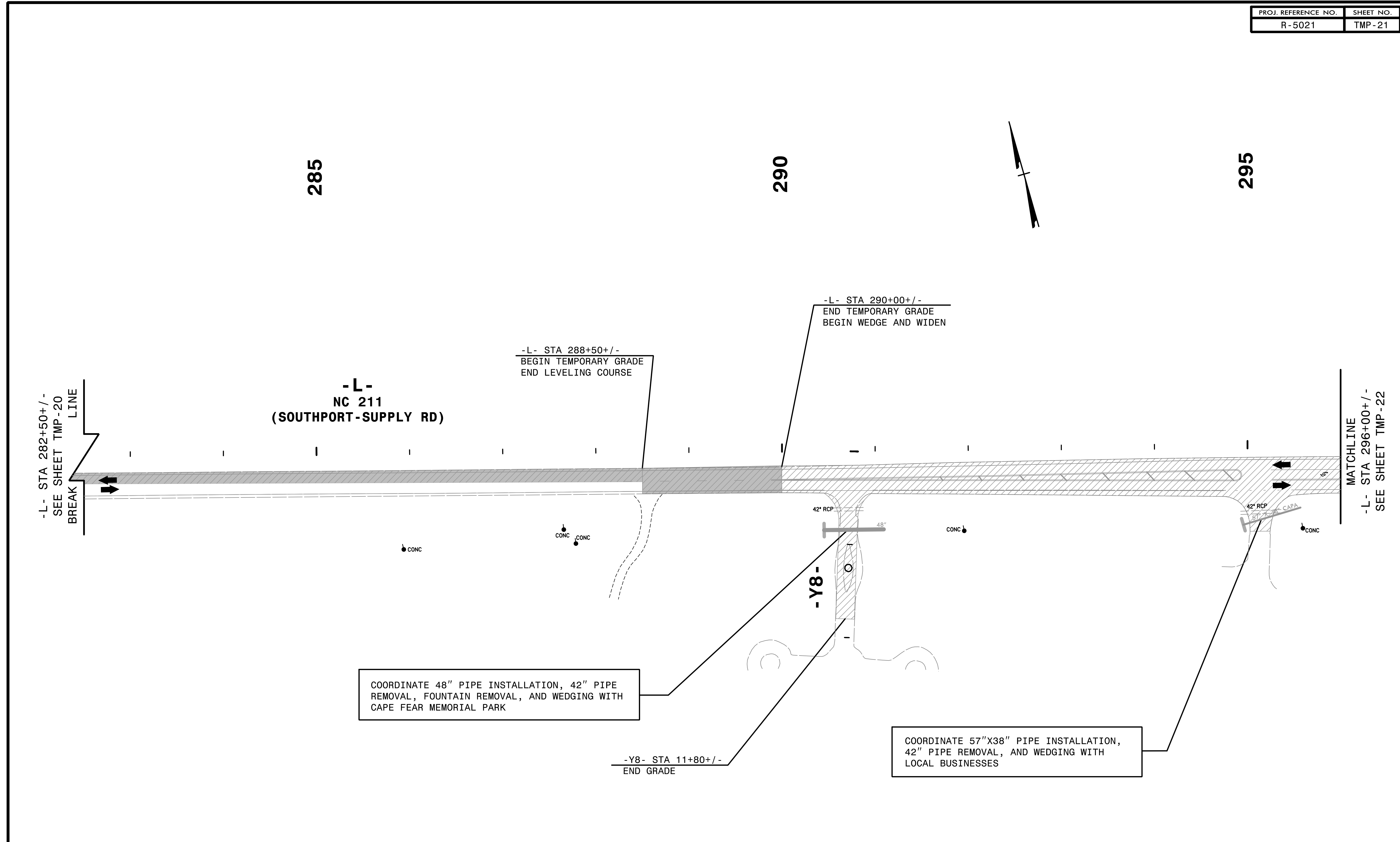

-L- STA 282+50+/-  
SEE SHEET TMP-20  
BREAK LINE

-L-  
NC 211  
(SOUTHPORT-SUPPLY RD)

-L- STA 288+50+/-  
BEGIN TEMPORARY GRADE  
END LEVELING COURSE

-L- STA 290+00+/-  
END TEMPORARY GRADE  
BEGIN WEDGE AND WIDEN

MATCHLINE  
-L- STA 296+00+/-  
SEE SHEET TMP-22

COORDINATE 48" PIPE INSTALLATION, 42" PIPE  
REMOVAL, FOUNTAIN REMOVAL, AND WEDGING WITH  
CAPE FEAR MEMORIAL PARK

-Y8- STA 11+80+/-  
END GRADE

COORDINATE 57"X38" PIPE INSTALLATION,  
42" PIPE REMOVAL, AND WEDGING WITH  
LOCAL BUSINESSES

REPLACE PAVEMENT MARKINGS IN EXISTING PATTERN.

2/6/2019  
HNTB

**HNTB** HNTB NORTH CAROLINA, P.C.  
343 E. Six Forks Road, Suite 200  
Raleigh, North Carolina 27609  
NC License No: C-1554

APPROVED: *Helen Skyy*  
DATE: 2/6/2019  
SEAL  
NORTH CAROLINA PROFESSIONAL ENGINEER SEAL 042517 HELEN SKYY

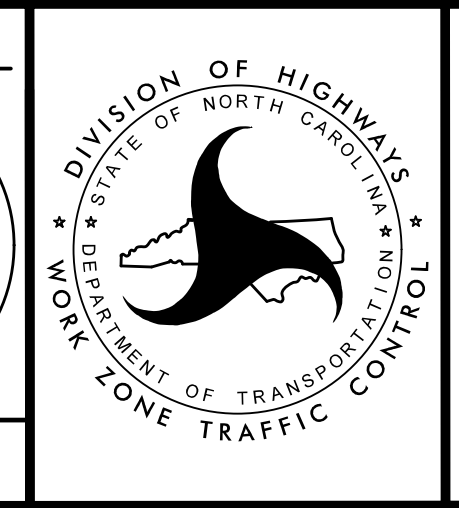

TRANSPORTATION  
MANAGEMENT PLAN  
  
PHASE I  
DETAIL

DOCUMENT NOT CONSIDERED FINAL  
UNLESS ALL SIGNATURES COMPLETED

PROJ. REFERENCE NO.	SHEET NO.
R-5021	TMP-22

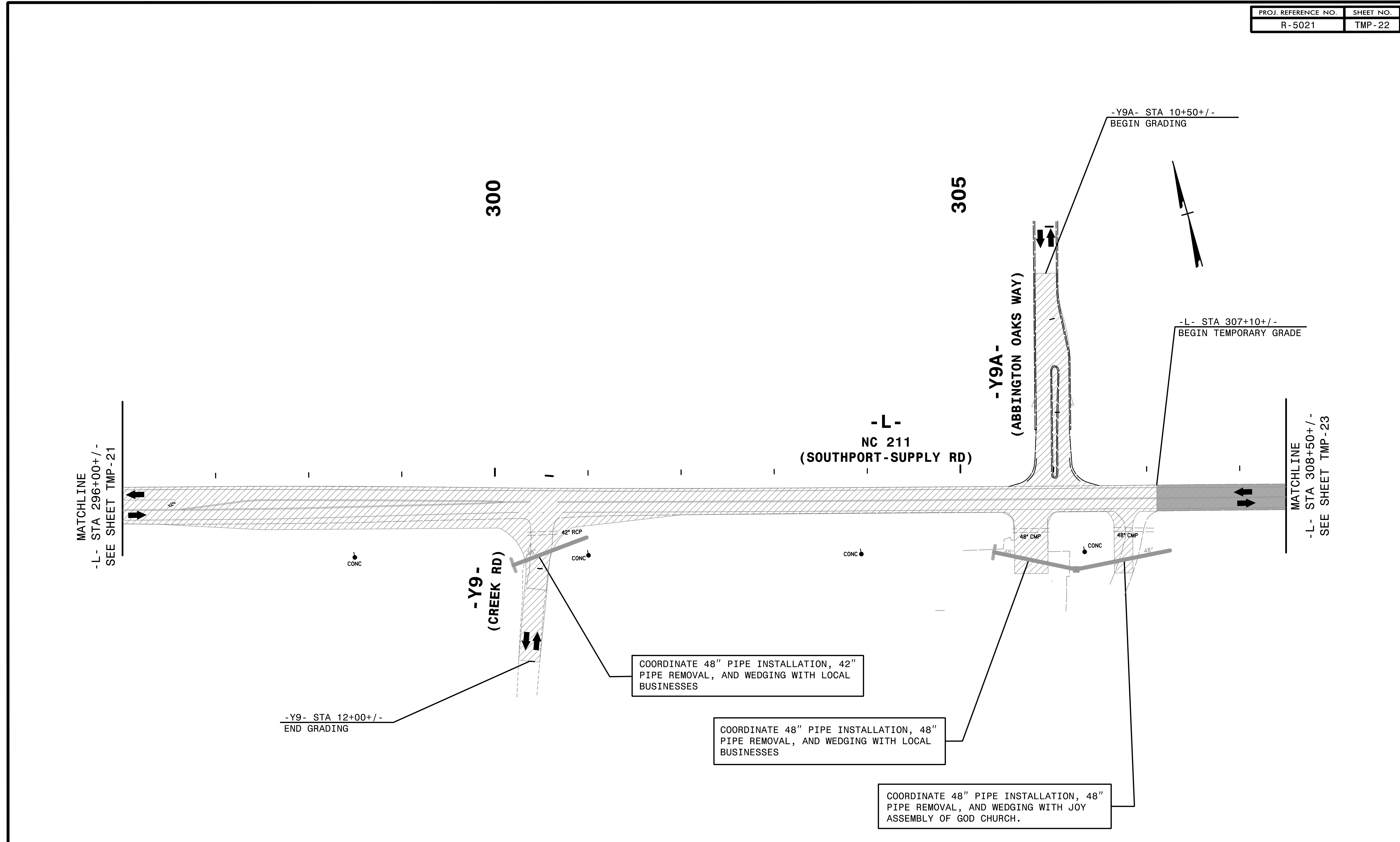

MATCHLINE  
-L- STA 296+00 +/-  
SEE SHEET TMP-21

MATCHLINE  
-L- STA 308+50 +/-  
SEE SHEET TMP-23

COORDINATE 48" PIPE INSTALLATION, 42"  
PIPE REMOVAL, AND WEDGING WITH LOCAL  
BUSINESSES

COORDINATE 48" PIPE INSTALLATION, 48"  
PIPE REMOVAL, AND WEDGING WITH LOCAL  
BUSINESSES

COORDINATE 48" PIPE INSTALLATION, 48"  
PIPE REMOVAL, AND WEDGING WITH JOY  
ASSEMBLY OF GOD CHURCH.

REPLACE PAVEMENT MARKINGS IN EXISTING PATTERN.

2/6/2019  
HNTB

**HNTB**  
HNTB NORTH CAROLINA, P.C.  
343 E. Six Forks Road, Suite 200  
Raleigh, North Carolina 27609  
NC License No: C-1554

APPROVED: *Helen Skyy*  
DATE: 2/6/2019  
SEAL  
Professional Engineer Seal for Helen Skyy, No. 042517, State of North Carolina.

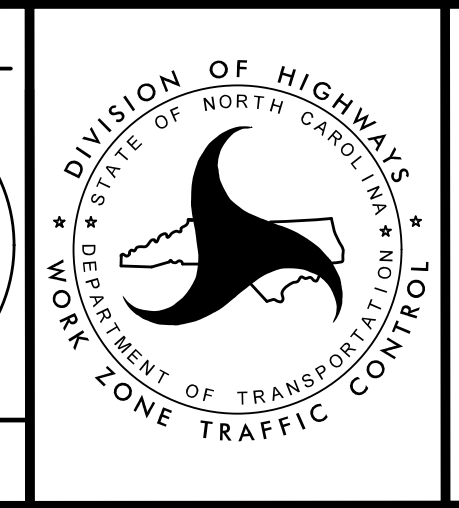

TRANSPORTATION  
MANAGEMENT PLAN  
  
PHASE I  
DETAIL

DOCUMENT NOT CONSIDERED FINAL  
UNLESS ALL SIGNATURES COMPLETED

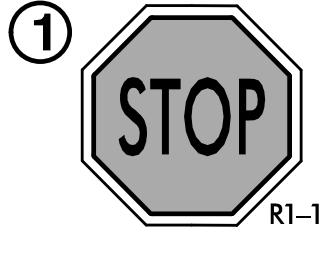

310

315

320

CONSTRUCT TEMP PAVEMENT AT EXISTING ELEVATION AND USE FLAGGERS AND TRENCHBOX TO INSTALL 48" PIPE. THEN USING FLAGGERS, WEDGE AND MILL -Y12- AND REMOVE EXCESS PAVEMENT

INSTALL TEMP GUARDRAIL. TIE INTO EXISTING GUARDRAIL AND ADJUST EXISTING GUARDRAIL AS NEEDED.

ADJUST GUARDRAIL AS NEEDED

-L- STA 315+00+/-  
END LEVELING COURSE  
BEGIN WIDEN AND WEDGE AT TEMP. SLOPE

-Y12- STA 12+37+/-  
11.6' RT  
BEGIN TEMPORARY PAVEMENT

-Y12- STA 11+55+/-  
END GRADE

-Y12- STA 12+86+/-  
32.0' RT

-L- STA 318+26+/-  
32.7' LT

-L- STA 317+95+/-  
18.32' LT  
END TEMPORARY PAVEMENT

-L- STA 308+82+/-  
END TEMPORARY GRADE  
BEGIN LEVELING COURSE

-L- STA 310+47+/-  
BEGIN TEMP. PAVEMENT

MATCHLINE  
-L- STA 308+50+/-  
SEE SHEET TMP-22

-L- STA 321+00+/-  
END WEDGING

MATCHLINE  
-L- STA 321+50+/-  
SEE SHEET TMP-24

-L-  
NC 211  
(SOUTHPORT-SUPPLY RD)

TEMPORARY PAVEMENT USED TO INSTALL DRAINAGE

INSTALL TEMPORARY GUARDRAIL WITH ADDITIONAL POSTS AS REQUIRED PER RSD 862.01 SHEET 1 OF 12"

STEEL PLATE REQUIRED

-Y10-  
(PATRICK NEWTON DR)

COORDINATE 54" PIPE INSTALLATION WITH LOCAL BUSINESS

CONSTRUCT TEMPORARY PAVEMENT AT EXISTING ELEVATION TIE INTO TEMPORARY DITCH

COORDINATE 54" PIPE INSTALLATION WITH SAINT PETER EVANGELICAL LUTHERAN CHURCH

-Y11- STA 314+88.5+/-  
55' RT

-Y11- STA 10+95+/-  
31.6' RT

-Y11- STA 12+17+/-

-Y11- STA 12+75+/-  
9.3' RT END TEMP PAVEMENT

-Y11- STA 13+25+/-  
END GRADE

CONSTRUCT TEMP PAVEMENT AT EXISTING ELEVATION AND USING FLAGGERS AND TRENCHBOX, INSTALL 54" CAAP. WEDGE AT -Y11- TO MINIMUM FILL HEIGHT. REMOVE EXCESS PAVEMENT

ADD TEMPORARY PIPE

SEE EC-23A/CONST.23 FOR CULVERT PHASING

-L- STA 316+40+/-  
47.00' RT  
BEGIN TEMPORARY PAVEMENT

-Y11- STA 10+85+/-  
35.00' LT

-Y11- STA 13+10+/-  
14.2' LT  
END TEMPORARY PAVEMENT

ADD QUANTITIES FOR REPLACING PAVEMENT MARKINGS IN EXISTING PATTERN

- (AA) PLACE TEMP SHOP CURVED TEMPORARY GUARDRAIL (69') AND TEMP AT-1
- (Y) PLACE PERM GUARDRAIL AT TEMP ELEV FROM STA 313+29+/- TO STA 314+89+/- AND TEMPORARY SHOP CURVED GUARDRAIL (40') WITH TEMP AT-1 AT TRAILING END.
- (Z) PLACE PERM GUARDRAIL AT TEMP ELEV FROM STA 316+41+/- TO STA 318+82+/- AND TEMP SHOP CURVED GUARDRAIL (42') WITH AT-1 AT APPROACH.

2/6/2019  
HNTB  
C:\CPV\502L\to\_pidit.dgn

**HNTB**  
HNTB NORTH CAROLINA, P.C.  
343 E. Six Forks Road, Suite 200  
Raleigh, North Carolina 27609  
NC License No: C-1554

APPROVED: *Helen Skyy*  
DATE: 2/6/2019  
SEAL  
DOCUMENT NOT CONSIDERED FINAL UNLESS ALL SIGNATURES COMPLETED

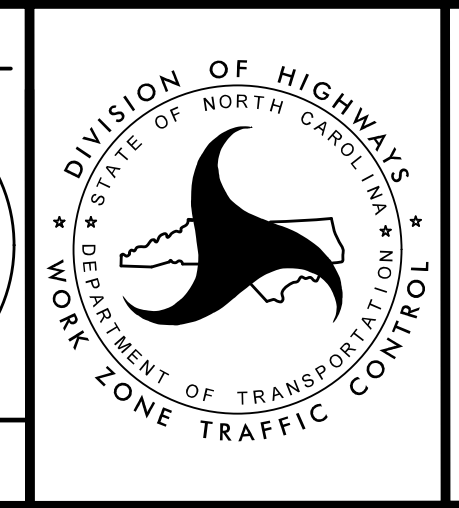

TRANSPORTATION MANAGEMENT PLAN  
  
PHASE I  
DETAIL

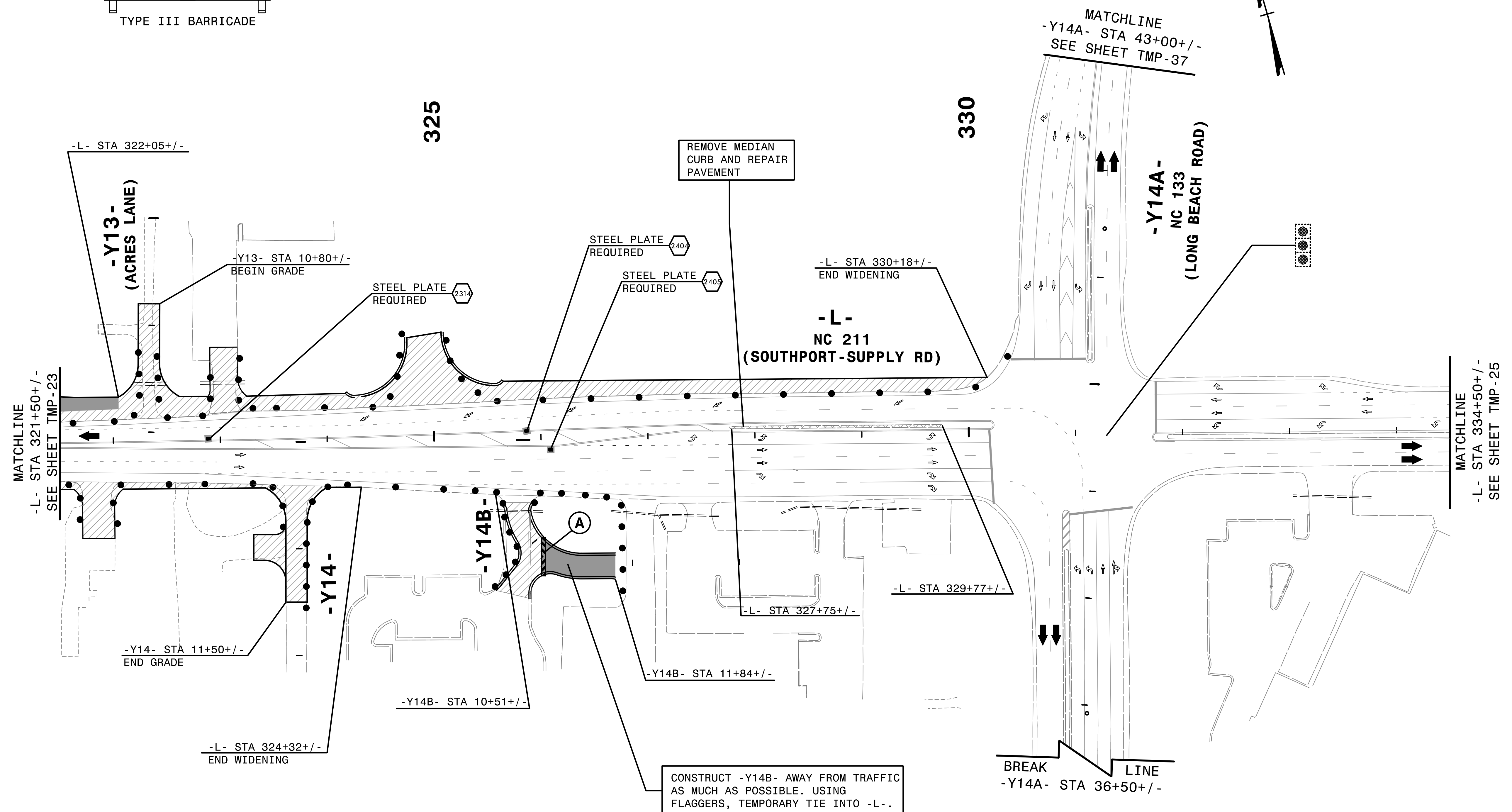
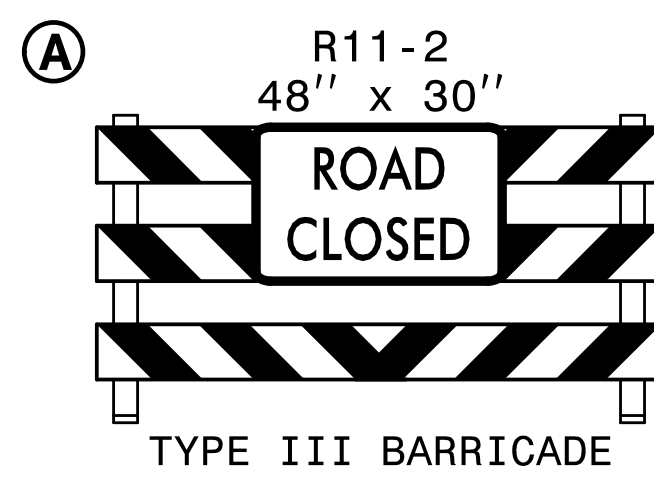

REPLACE PAVEMENT MARKING IN EXISTING PATTERN.

2/6/2019  
HNTB

**HNTB**  
HNTB NORTH CAROLINA, P.C.  
343 E. Six Forks Road, Suite 200  
Raleigh, North Carolina 27609  
NC License No: C-1554

APPROVED: *Helen Skyy*  
DATE: 2/6/2019  
SEAL  
DOCUMENT NOT CONSIDERED FINAL  
UNLESS ALL SIGNATURES COMPLETED

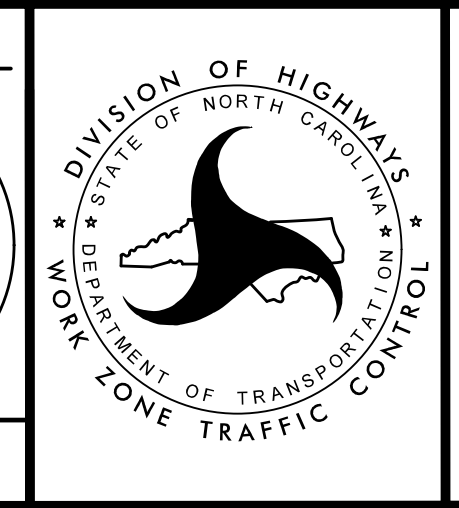

TRANSPORTATION  
MANAGEMENT PLAN  
  
PHASE I  
DETAIL

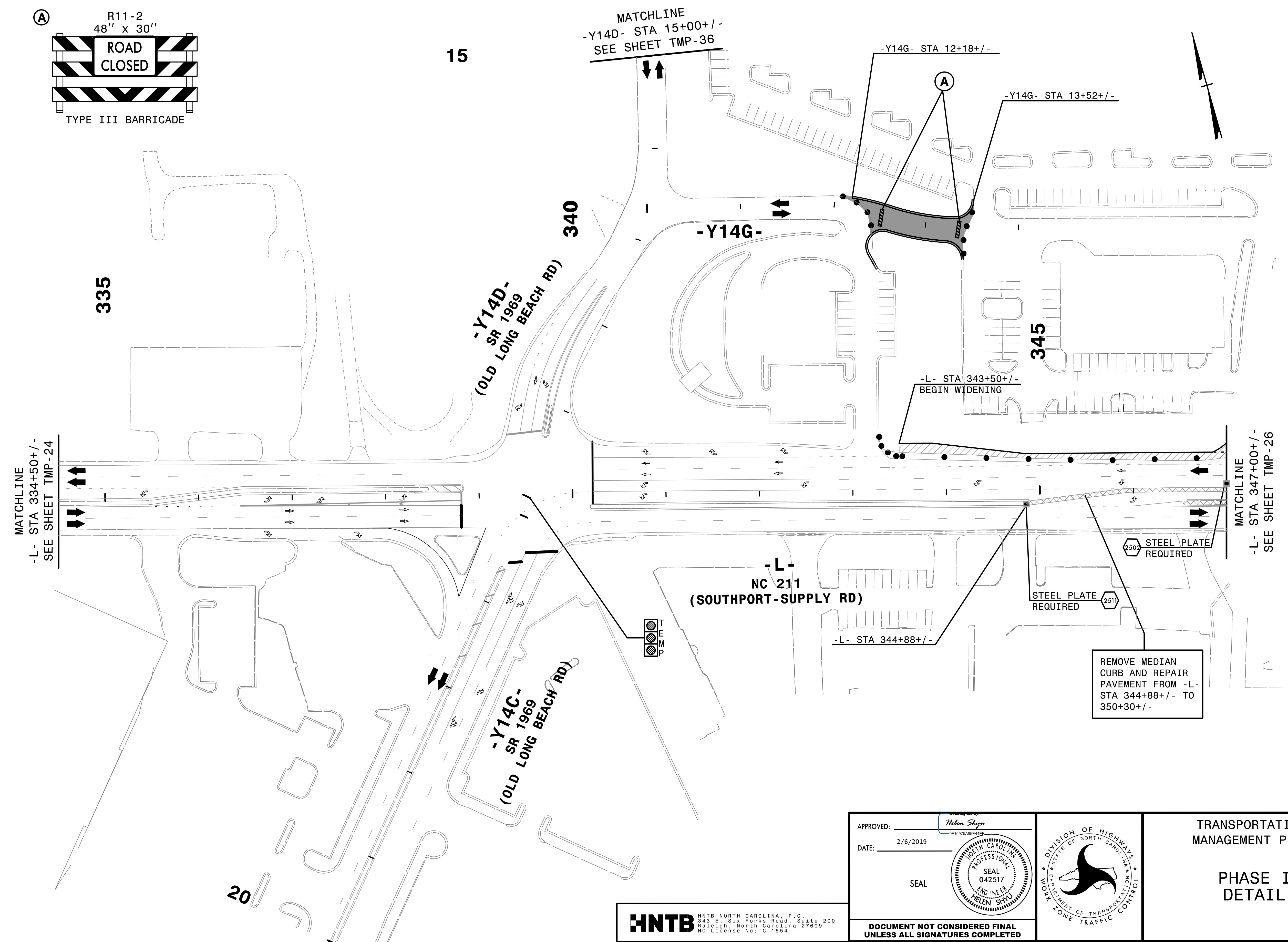
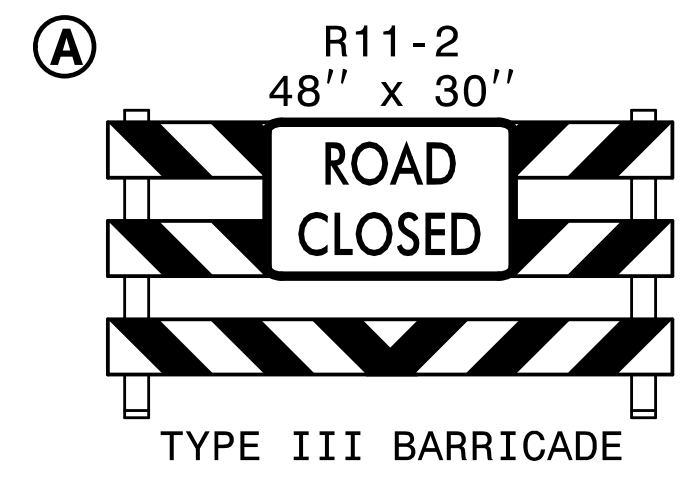

2/6/2019  
TCPLV-5021.tc\_pid19.dgn  
HNTB

**HNTB**  
HNTB NORTH CAROLINA, P.C.  
343 E. Six Forks Road, Suite 200  
Raleigh, North Carolina 27609  
NC License No: C-1554

APPROVED: *Helen Skyy*  
DATE: 2/6/2019  
SEAL  
HNTB NORTH CAROLINA  
PROFESSIONAL  
SEAL  
042517  
ENGINEER  
HELEN SKYY

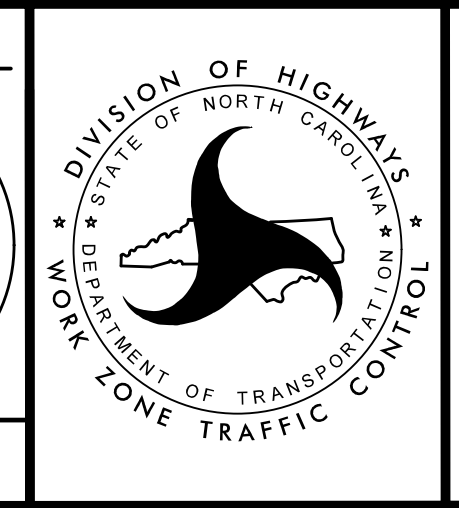

TRANSPORTATION  
MANAGEMENT PLAN  
  
PHASE I  
DETAIL

DOCUMENT NOT CONSIDERED FINAL  
UNLESS ALL SIGNATURES COMPLETED





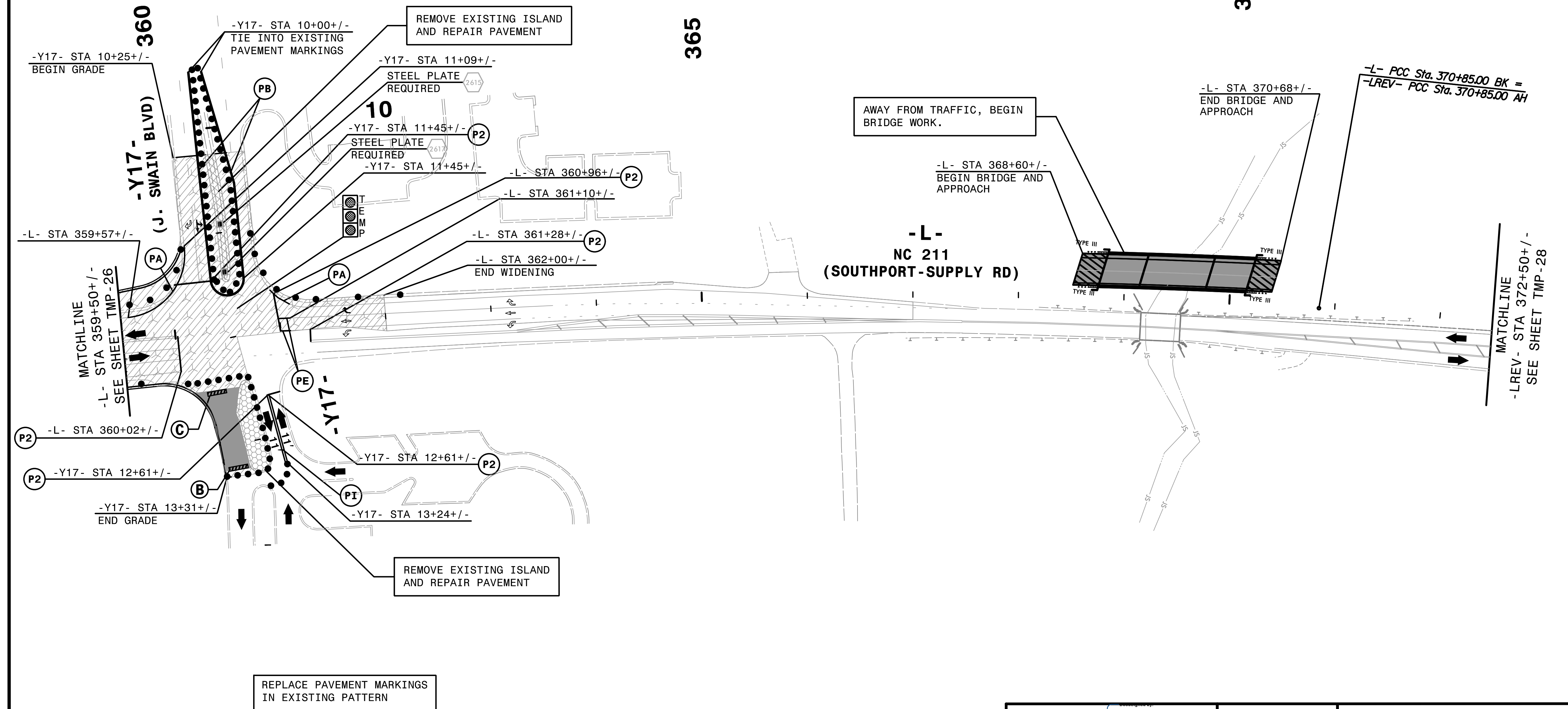
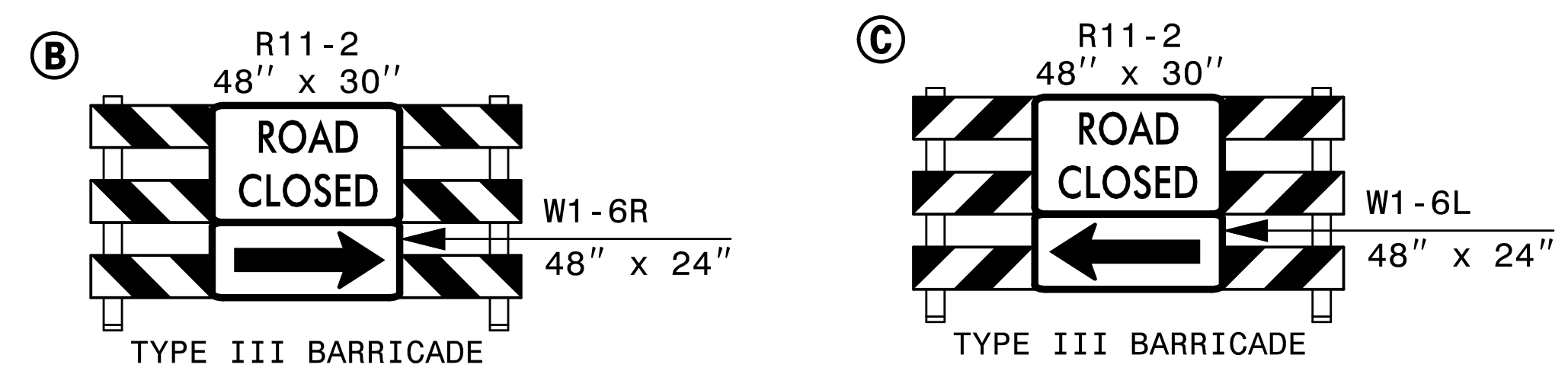

2/6/2019  
C:\CPV\5021\Tc\_pid21.dgn  
HNTB

**HNTB** HNTB NORTH CAROLINA, P.C.  
343 E. Six Forks Road, Suite 200  
Raleigh, North Carolina 27609  
NC License No: C-1554

APPROVED: *Helen Skyy*  
DATE: 2/6/2019  
SEAL  
DOCUMENT NOT CONSIDERED FINAL  
UNLESS ALL SIGNATURES COMPLETED

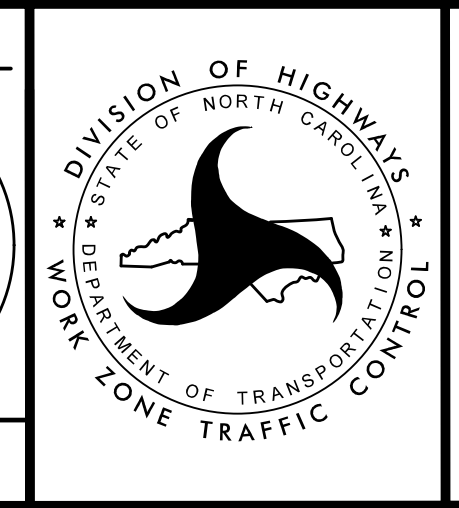

TRANSPORTATION  
MANAGEMENT PLAN  
  
PHASE I  
DETAIL

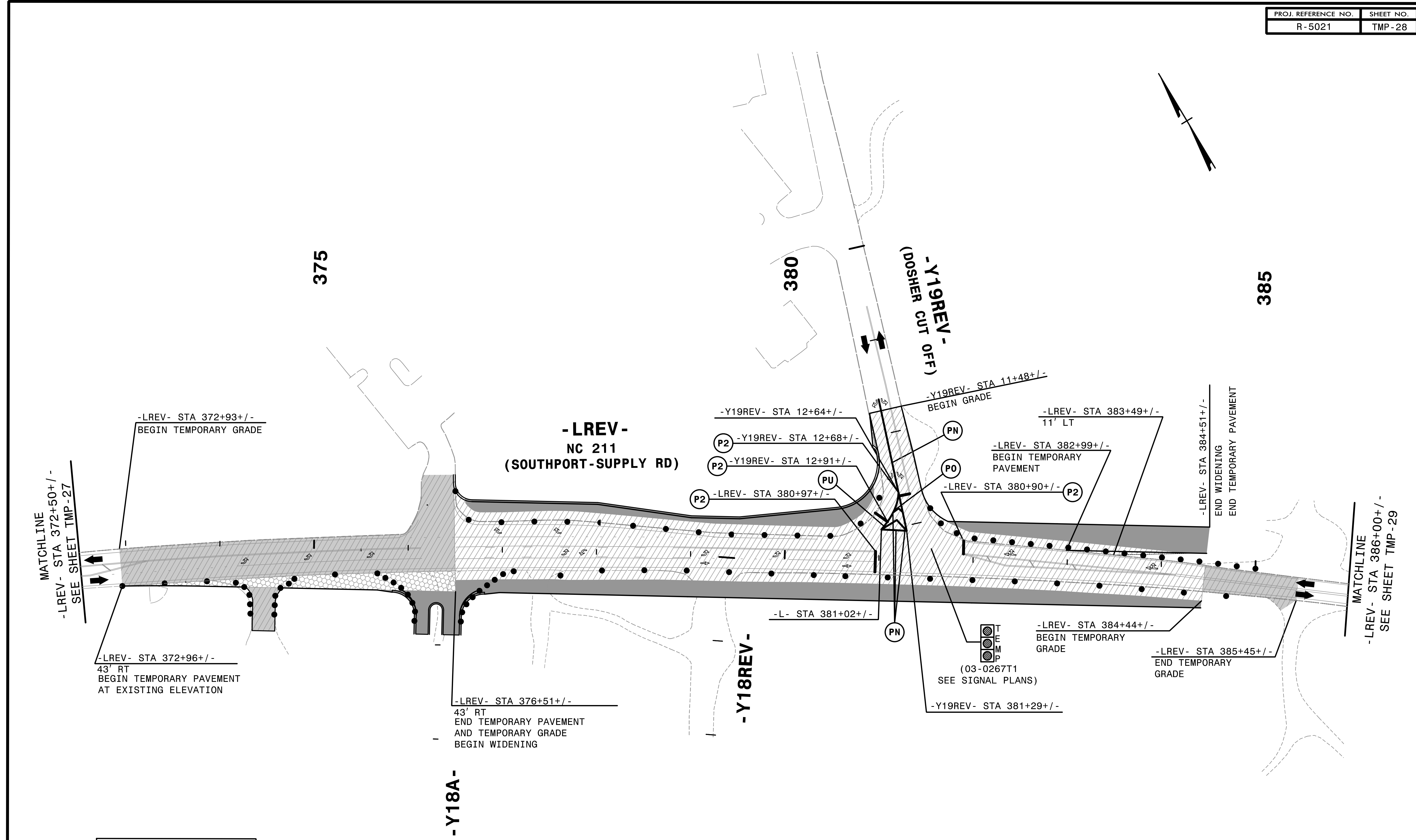

APPROVED: *Helen Shyne*  
DATE: 9/9/2021

SEAL

DOCUMENT NOT CONSIDERED FINAL  
UNLESS ALL SIGNATURES COMPLETED

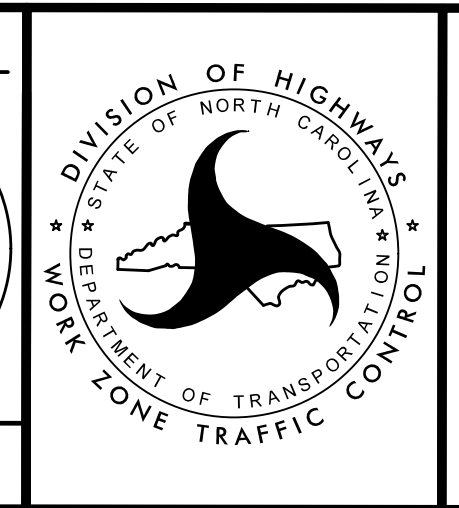

TRANSPORTATION  
MANAGEMENT PLAN

PHASE I  
DETAIL

**HNTB** HNTB NORTH CAROLINA, P.C.  
343 E. SIX FORKS ROAD, SUITE 200  
RALEIGH, NORTH CAROLINA 27609  
NC LICENSE NO: C-1554

PROJ. REFERENCE NO.	SHEET NO.
R-5021	TMP - 29

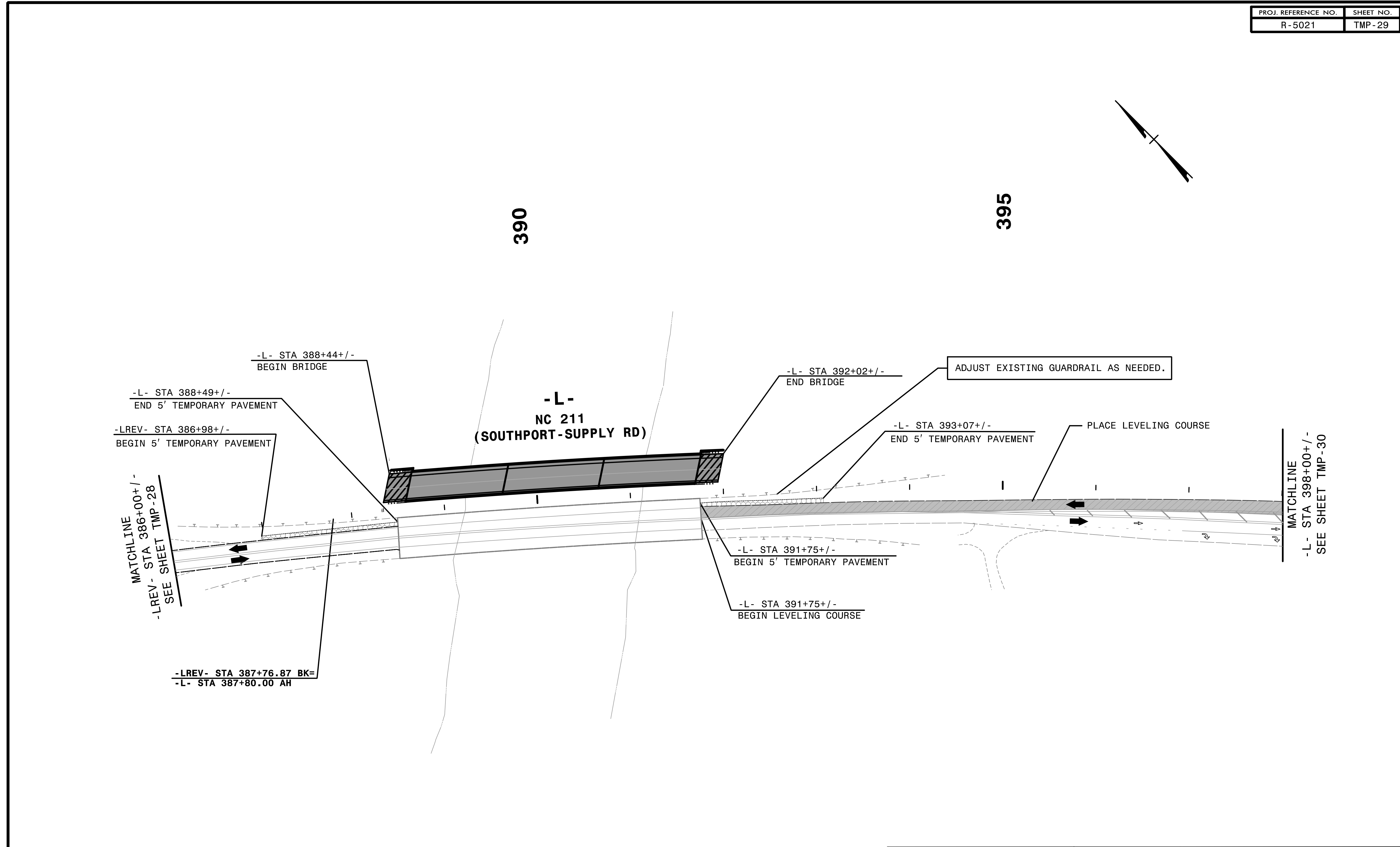

2/6/2019  
HNTB

REPLACE PAVEMENT MARKING  
IN EXISTING PATTERN

**HNTB** HNTB NORTH CAROLINA, P.C.  
343 E. Six Forks Road, Suite 200  
Raleigh, North Carolina 27609  
NC License No: C-1554

APPROVED: *Helen Skyy*  
DATE: 2/6/2019  
SEAL  
DOCUMENT NOT CONSIDERED FINAL  
UNLESS ALL SIGNATURES COMPLETED

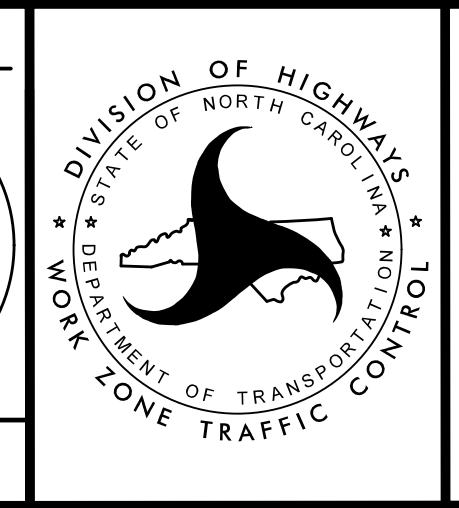

TRANSPORTATION  
MANAGEMENT PLAN  
  
PHASE I  
DETAIL

PROJ. REFERENCE NO.	SHEET NO.
R-5021	TMP-30

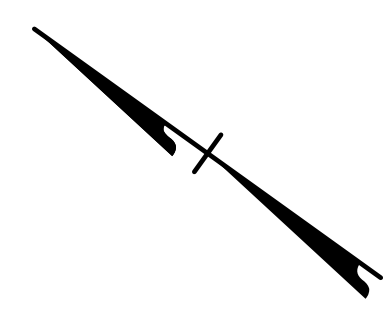
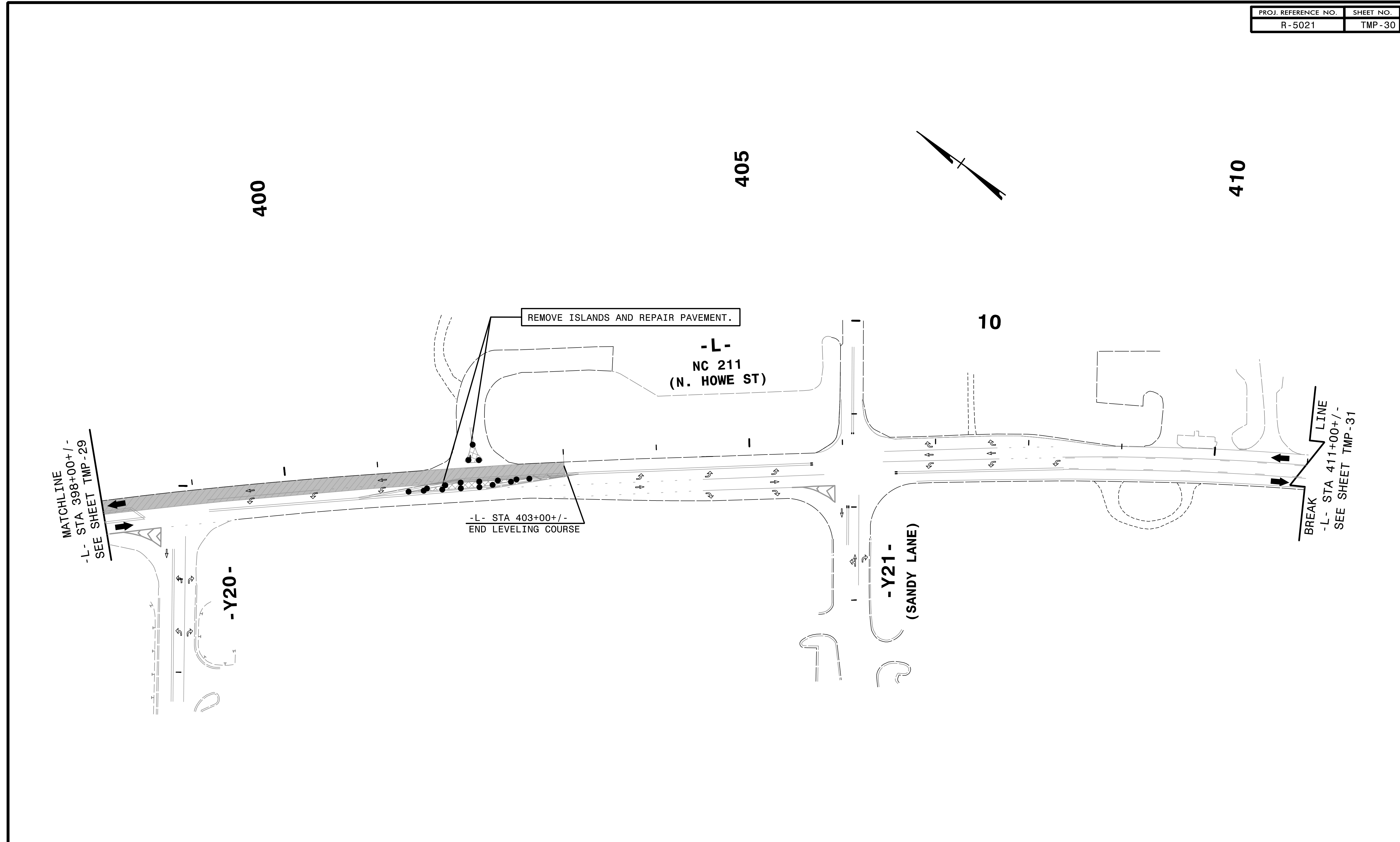

2/6/2019  
 C:\CP\5021\TC\_pid24.dgn  
 HNTB

REPLACE PAVEMENT MARKING  
 IN EXISTING PATTERN

**HNTB** HNTB NORTH CAROLINA, P.C.  
 343 E. Six Forks Road, Suite 200  
 Raleigh, North Carolina 27609  
 NC License No: C-1554

APPROVED: *Helen Skyy*  
OF 1987SAPPLICABLE

DATE: 2/6/2019

SEAL

**PROFESSIONAL SEAL**  
 ENGINEER  
 HELEN SKYY

**DOCUMENT NOT CONSIDERED FINAL  
 UNLESS ALL SIGNATURES COMPLETED**

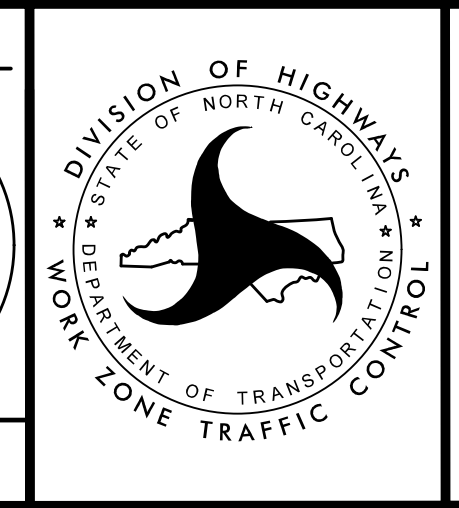

TRANSPORTATION  
 MANAGEMENT PLAN

**PHASE I  
 DETAIL**

4:56:05 PM  
\\TCPL15021\cpl\d26.dgn  
\$\$\$\$\$USERNAME\$\$\$\$\$

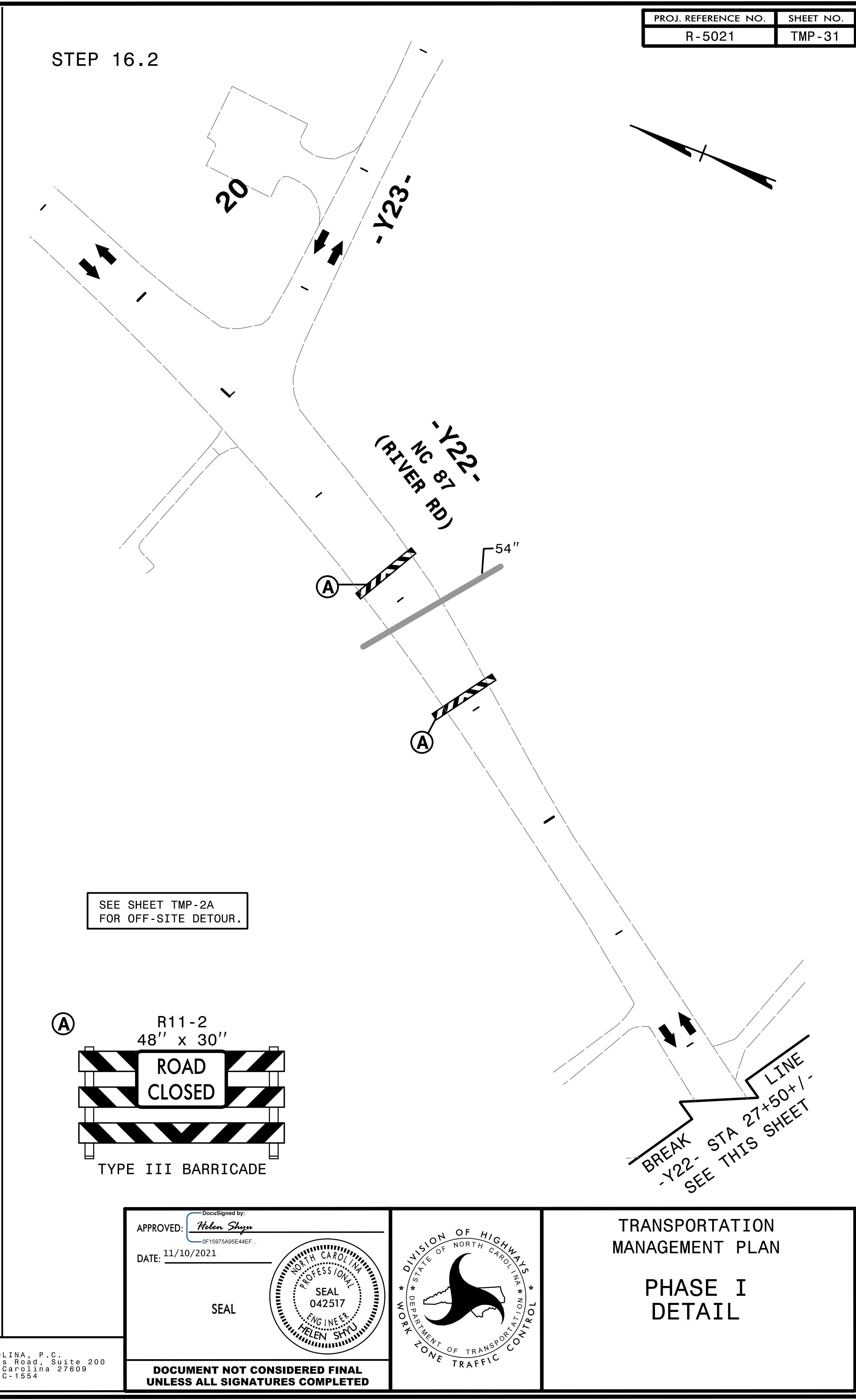
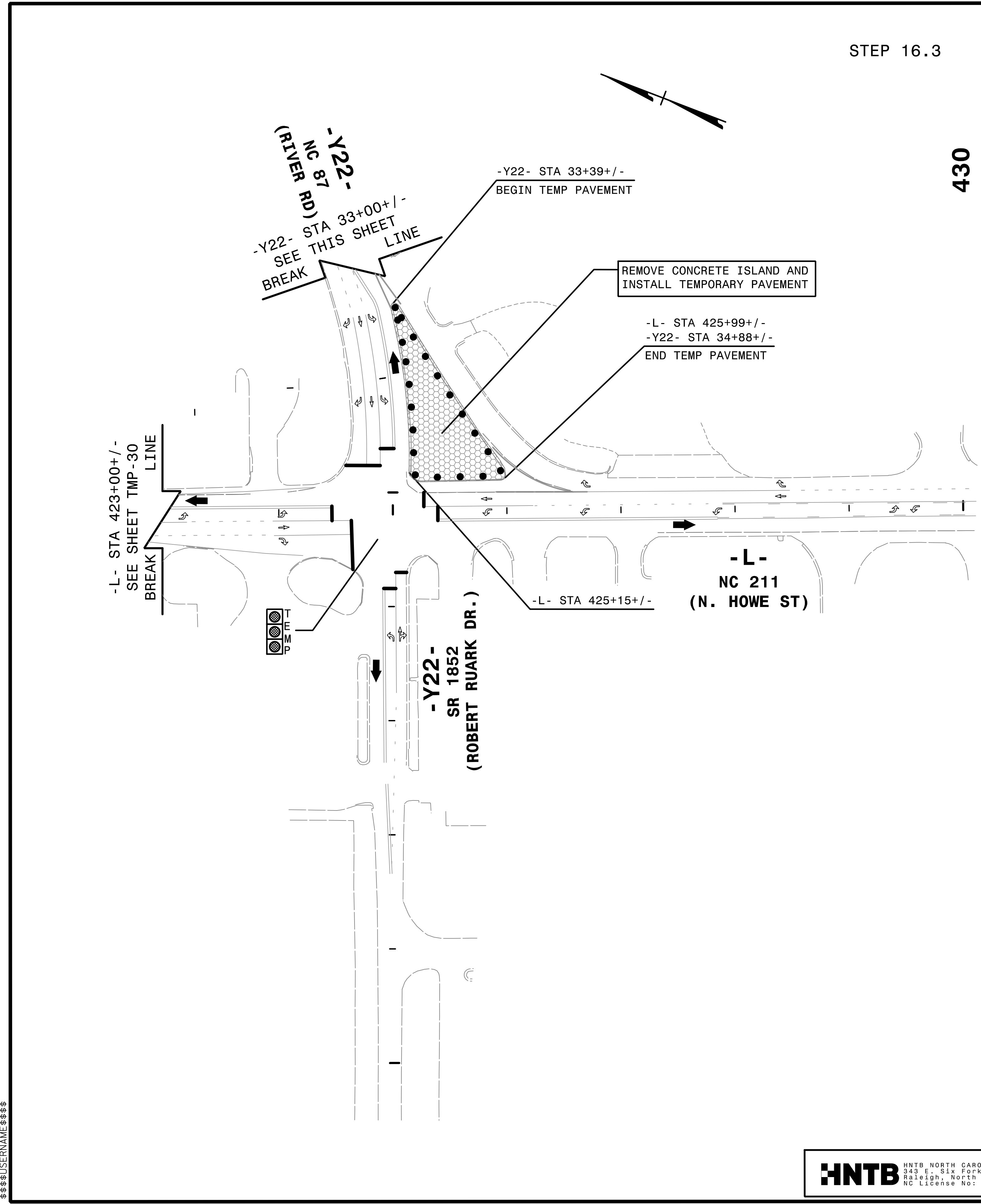

STEP 16.3

STEP 16.2

430

SEE SHEET TMP-2A  
FOR OFF-SITE DETOUR.

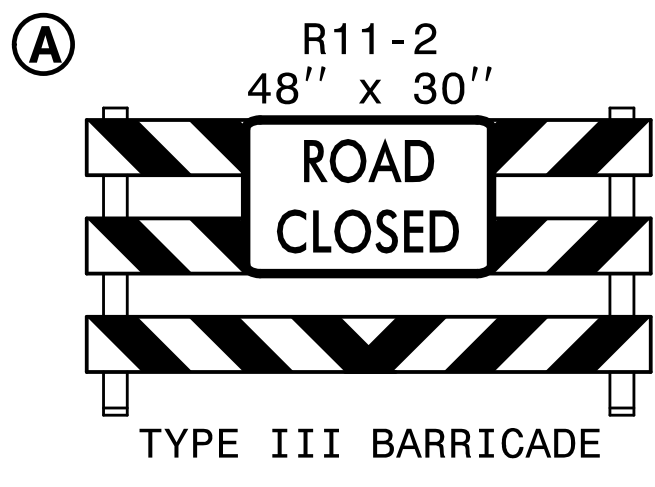

APPROVED: *Helen Shyu*  
DATE: 11/10/2021

SEAL

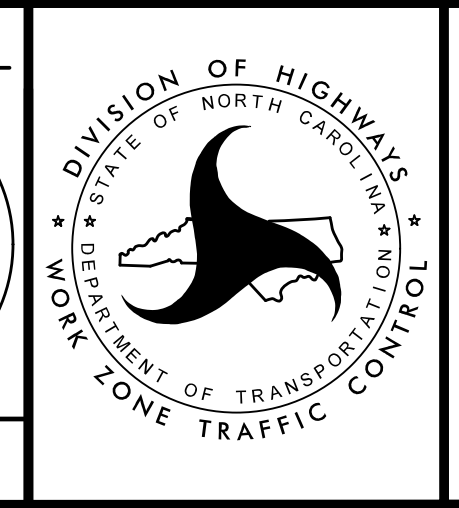

TRANSPORTATION  
MANAGEMENT PLAN

PHASE I  
DETAIL

**HNTB** HNTB NORTH CAROLINA, P.C.  
343 E. Six Forks Road, Suite 200  
Raleigh, North Carolina 27609  
NC License No: C-1554

DOCUMENT NOT CONSIDERED FINAL  
UNLESS ALL SIGNATURES COMPLETED

PROJ. REFERENCE NO.	SHEET NO.
R-5021	TMP-32

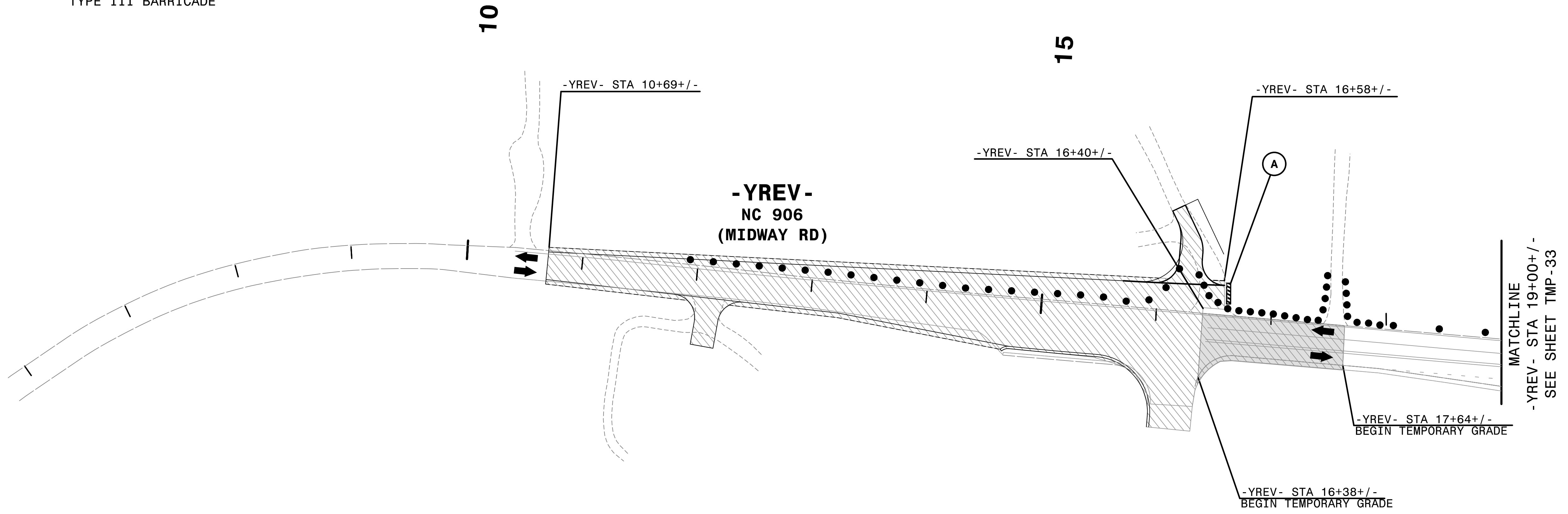
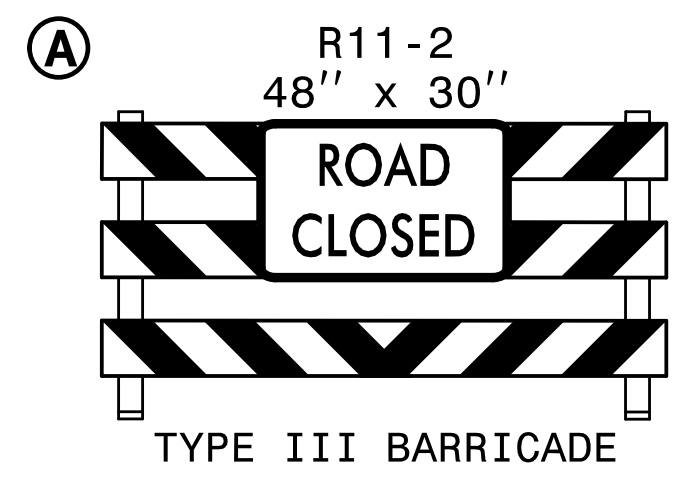

REPLACE PAVEMENT MARKINGS IN EXISTING PATTERN

4:52:38 PM  
\\TCPS\F5021\TC\_pid27.dgn  
\$\$\$\$\$USERNAME\$\$\$\$\$

**HNTB** HNTB NORTH CAROLINA, P.C.  
343 E. Six Forks Road, Suite 200  
Raleigh, North Carolina 27609  
NC License No: C-1554

APPROVED: *Helen Shyu*  
DATE: 9/9/2021

SEAL

PROFESSIONAL SEAL  
042517  
ENGINEER  
HELEN SHYU

DOCUMENT NOT CONSIDERED FINAL  
UNLESS ALL SIGNATURES COMPLETED

TRANSPORTATION  
MANAGEMENT PLAN

PHASE I  
DETAIL

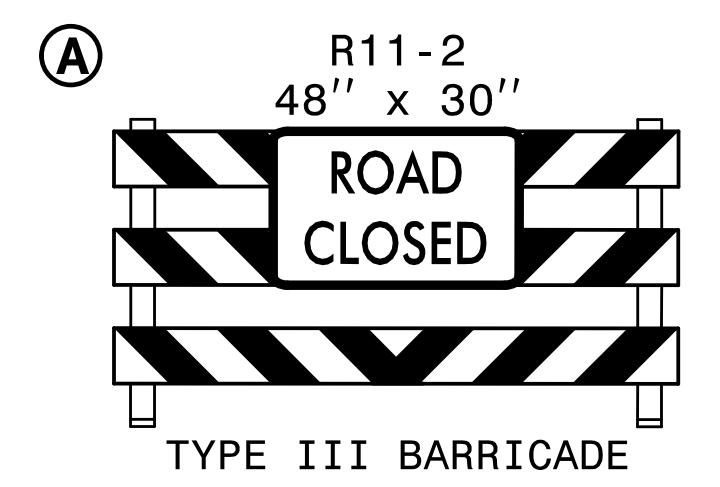
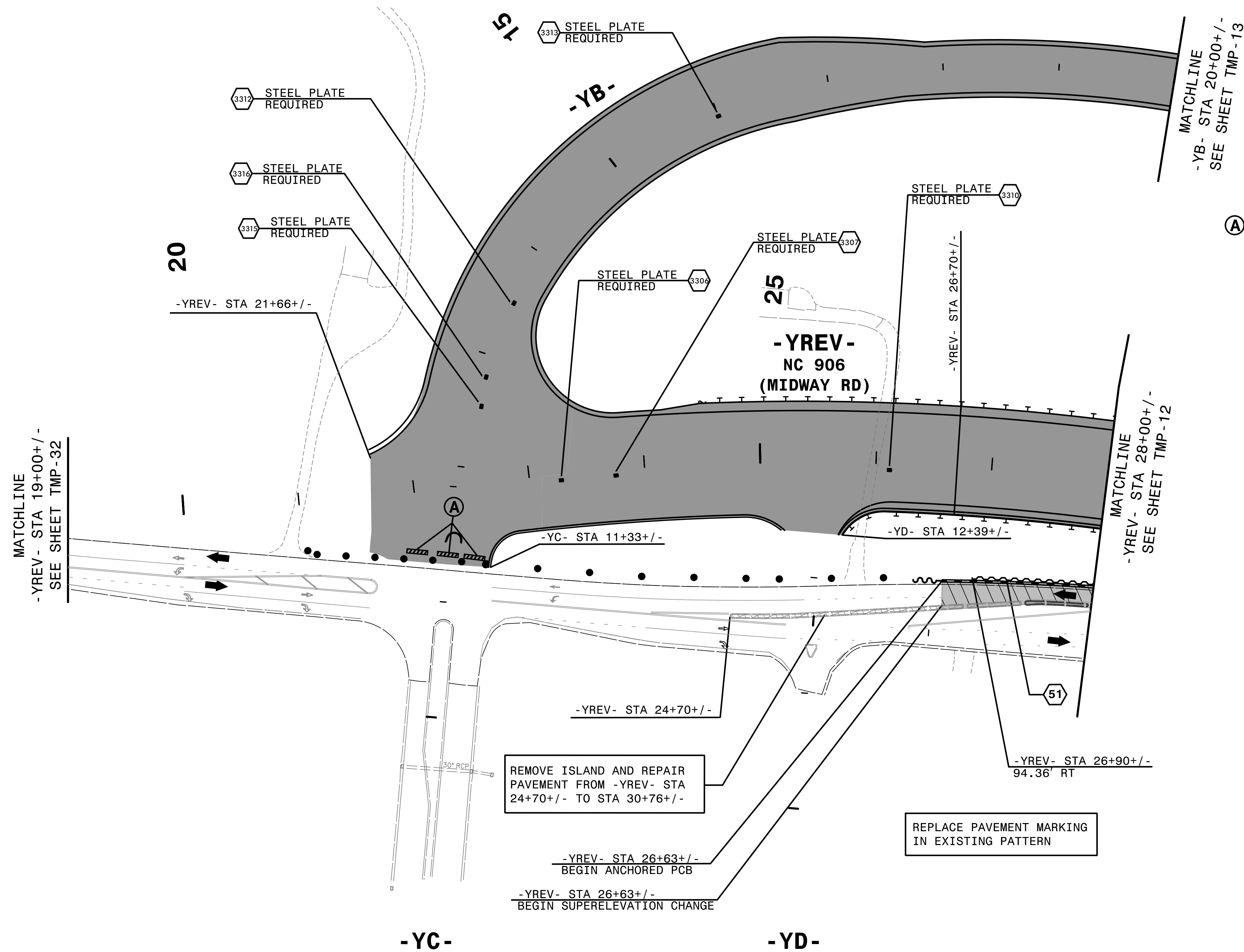

51 EST QUANTITY = 3380 SF

TEMPORARY SHORING  
 FROM -YREV- STA 26+90.07+/-, 94.36' RT  
 TO -YREV- STA 28+41.36, 86.36' RT  
 FROM -YREV- STA 28+41.36, 86.36' RT  
 TO -YREV- STA 30+37.27+/-, 65.17' RT  
 (SEE SHEET TMP-2G FOR  
 TEMPORARY SHORING NOTES)

4:52:42 PM  
 \\TCFV\502\1\c\_pl\d28.dgn  
 \$\$\$USERNAME\$\$\$

**HNTB** HNTB NORTH CAROLINA, P.C.  
 343 E. Six Forks Road, Suite 200  
 Raleigh, North Carolina 27609  
 NC License No: C-1554

APPROVED: *Helen Shyu*  
 DATE: 9/9/2021  
 SEAL  
 DOCUMENT NOT CONSIDERED FINAL  
 UNLESS ALL SIGNATURES COMPLETED

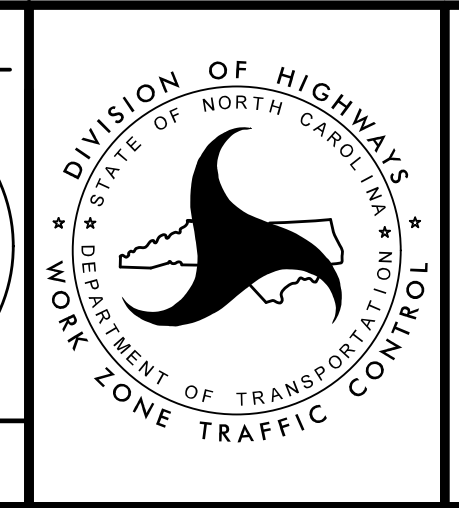

TRANSPORTATION  
 MANAGEMENT PLAN  
 PHASE I  
 DETAIL



35  
 MATCHLINE  
 -YREV- STA 35+00+/-  
 SEE SHEET TMP-12

-YREV-  
 NC 906  
 (MIDDLETON BLVD)

40

45

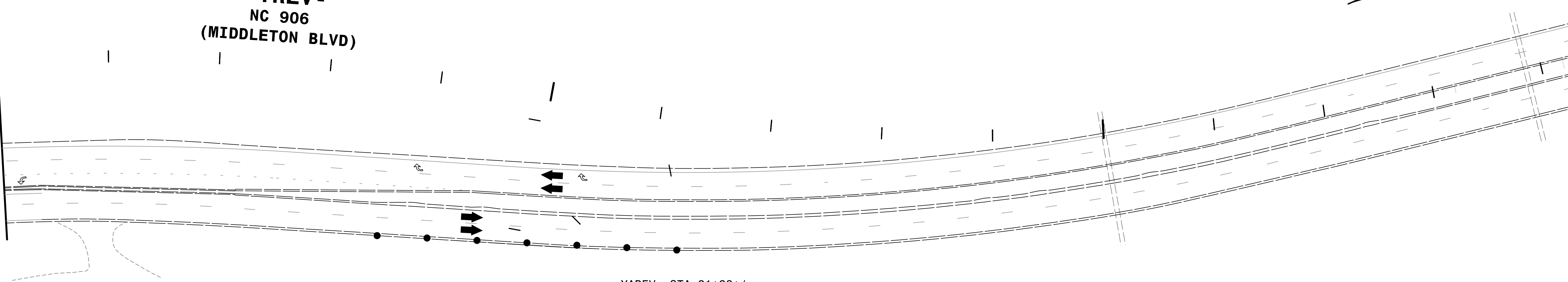
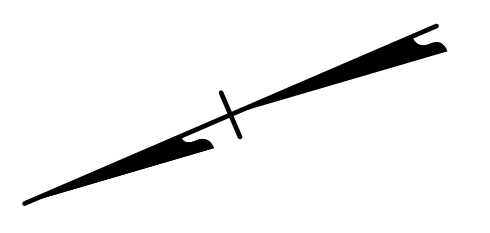

20

-YAREV-  
 10

-YAREV- STA 21+28+/-

-YG-  
 10

MATCHLINE  
 -YAREV- STA 15+50+/-  
 SEE SHEET TMP-12

3/23/08 PM  
 \\TCP\...R5021\...pld29.dgn  
 \$\$\$USERNAME\$\$\$

**HNTB**  
 HNTB NORTH CAROLINA, P.C.  
 343 E. Six Forks Road, Suite 200  
 Raleigh, North Carolina 27609  
 NC License No: C-1554

APPROVED: *Helen Shyu*  
 DATE: 10/28/2021  
 SEAL  
 DOCUMENT NOT CONSIDERED FINAL  
 UNLESS ALL SIGNATURES COMPLETED



TRANSPORTATION  
 MANAGEMENT PLAN  
 PHASE I  
 DETAIL

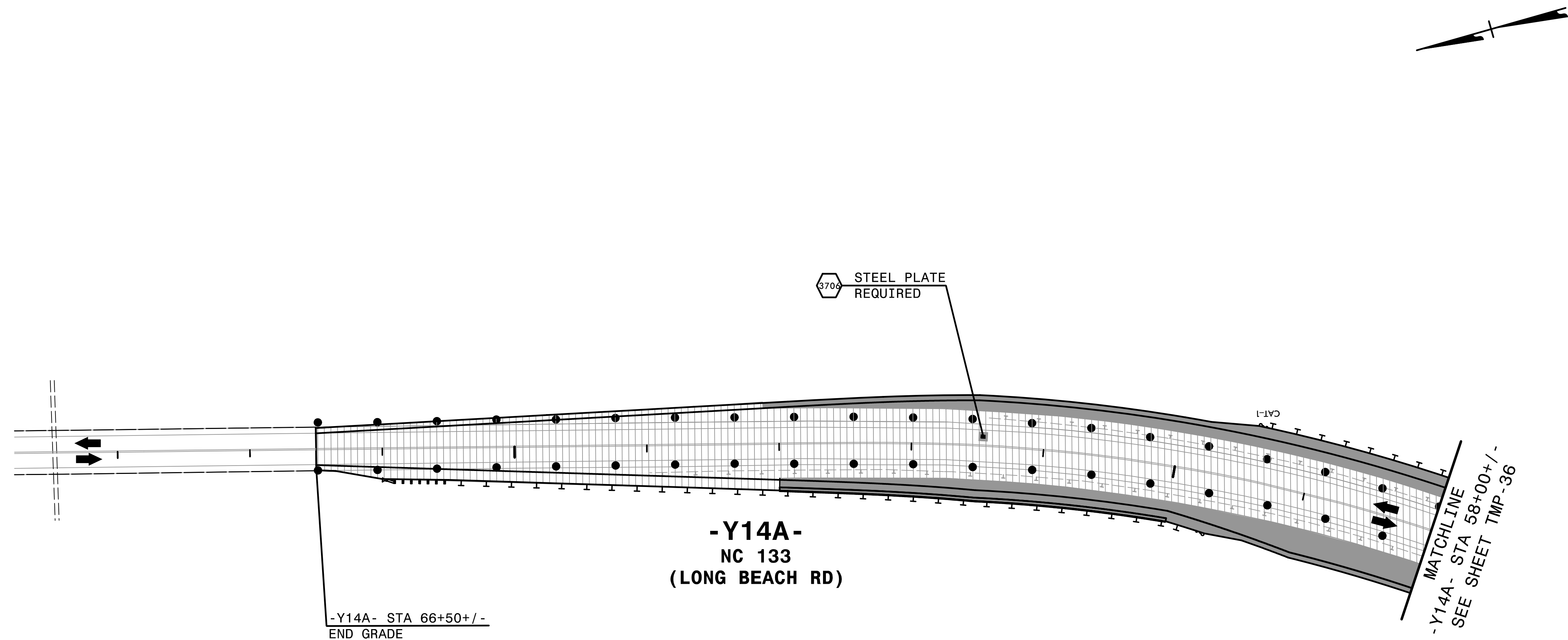

REPLACE PAVEMENT MARKING  
IN EXISTING PATTERN

65

09

2/6/2019  
TCR-V-5021-10-pld32.dgn  
HNTB

**HNTB** HNTB NORTH CAROLINA, P.C.  
343 E. Six Forks Road, Suite 200  
Raleigh, North Carolina 27609  
NC License No: C-1554

APPROVED: *Helen Shyu*  
DATE: 2/6/2019  
SEAL  
DOCUMENT NOT CONSIDERED FINAL  
UNLESS ALL SIGNATURES COMPLETED

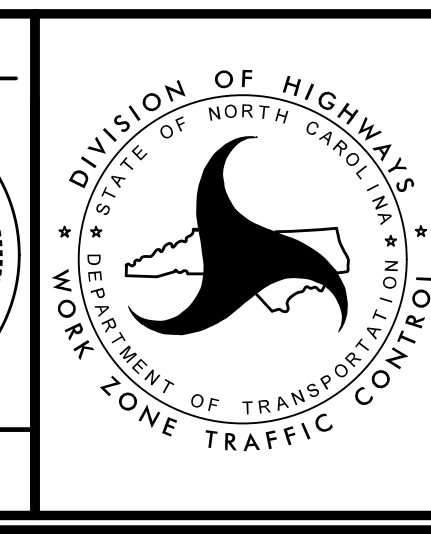

TRANSPORTATION  
MANAGEMENT PLAN  
  
PHASE I  
DETAIL

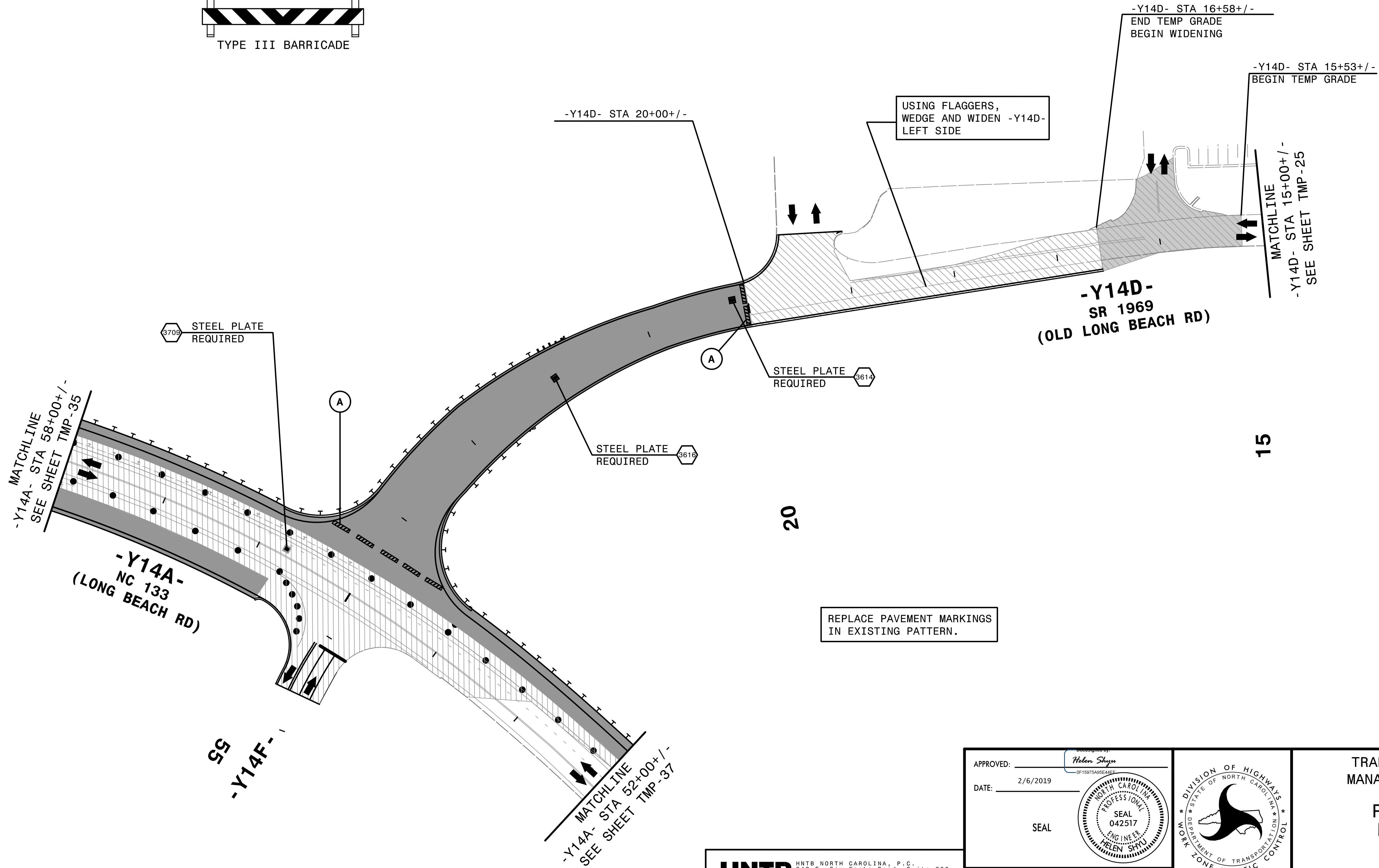
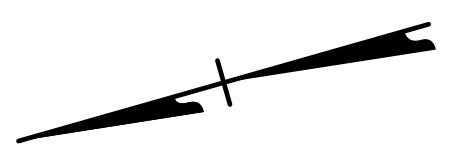
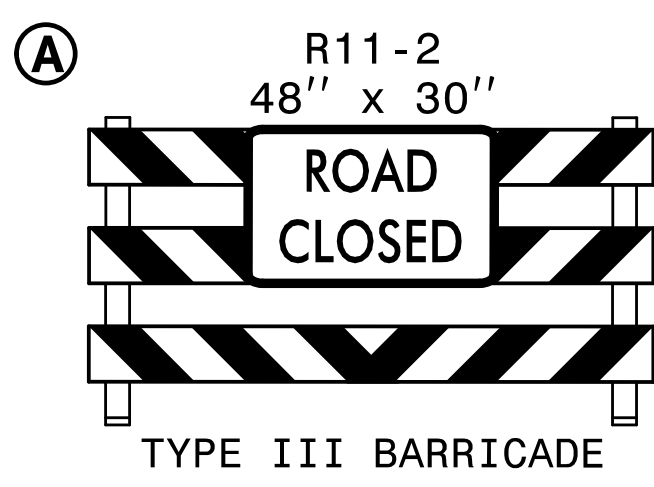

2/6/2019  
HNTB  
TCR\5021\to\_pl\35.dgn

**HNTB** HNTB NORTH CAROLINA, P.C.  
343 E. Six Forks Road, Suite 200  
Raleigh, North Carolina 27609  
NC License No: C-1554

APPROVED: *Helen Shyu*  
DATE: 2/6/2019  
SEAL  
Helen Shyu  
Professional Engineer  
No. 042517  
State of North Carolina

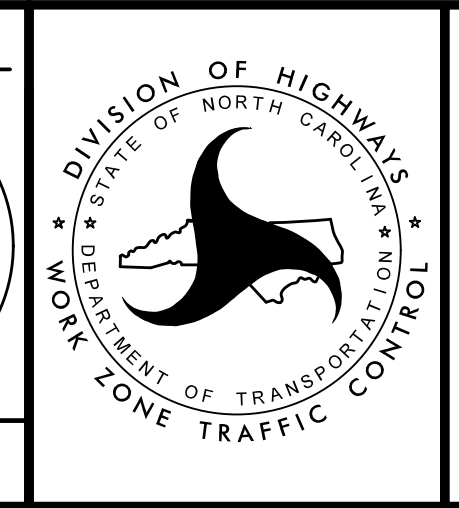

TRANSPORTATION  
MANAGEMENT PLAN  
  
PHASE I  
DETAIL

PROJ. REFERENCE NO.	SHEET NO.
R-5021	TMP-37

MATCHLINE  
-Y14A- STA 52+00+/-  
SEE SHEET TMP-36

-Y14A- STA 49+34+/-  
END TEMP GRADE  
BEGIN WEDGE AND WIDEN

-Y14A- STA 48+67+/-  
BEGIN TEMP GRADE

50

-Y14E-  
-Y14A-  
NC 133  
(LONG BEACH RD)

REPLACE PAVEMENT MARKINGS  
IN EXISTING PATTERN

MATCHLINE  
-Y14A- STA 43+00+/-  
SEE SHEET TMP-24

45

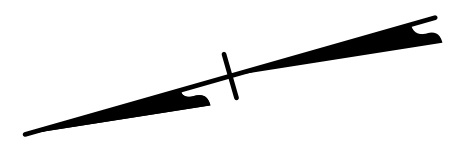

2/6/2019  
TCR\5021\to\_plid33.dgn  
HNTB

**HNTB**  
HNTB NORTH CAROLINA, P.C.  
343 E. Six Forks Road, Suite 200  
Raleigh, North Carolina 27609  
NC License No: C-1554

APPROVED: *Helen Shyu*  
DATE: 2/6/2019  
SEAL  
Helen Shyu  
Professional Engineer  
042517  
State of North Carolina

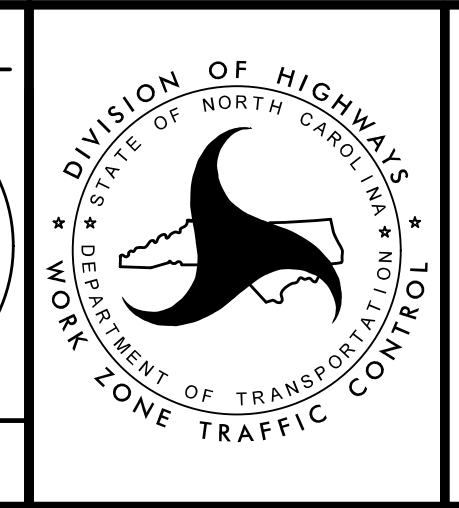

TRANSPORTATION  
MANAGEMENT PLAN  
  
PHASE I  
DETAIL

DOCUMENT NOT CONSIDERED FINAL  
UNLESS ALL SIGNATURES COMPLETED

PROJ. REFERENCE NO.	SHEET NO.
R-5021	TMP-38

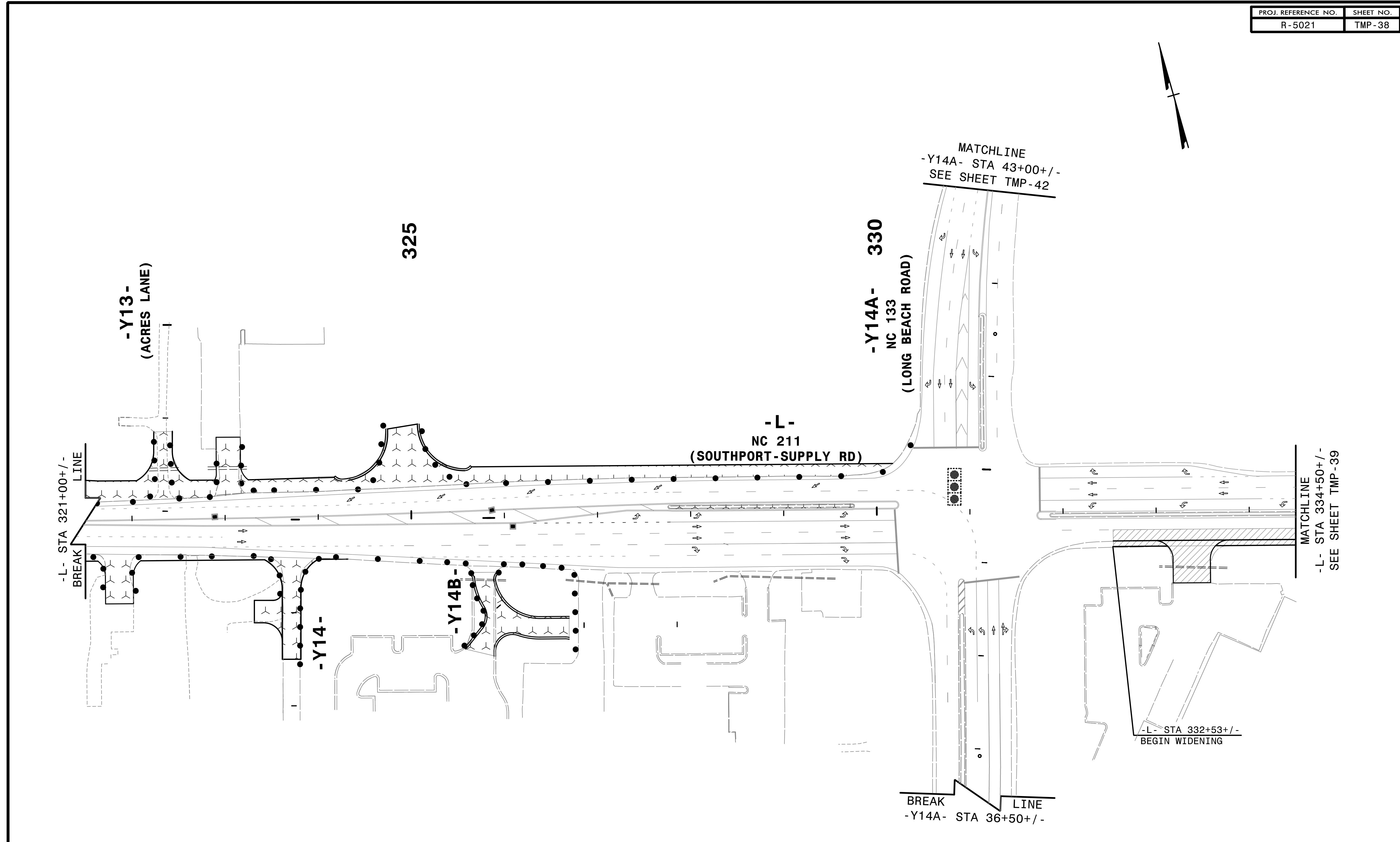
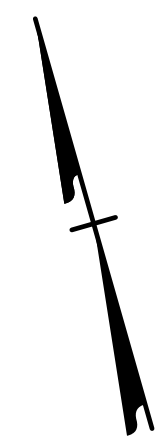

SEE TMP-24 FOR OTHER WORK BETWEEN STA 321+50+/- AND STA 330+18+/-

4:56:08 PM  
 \\TCFV\5021\to\_pid18 detour.dgn  
 \$\$\$USERNAME\$\$\$

**HNTB** HNTB NORTH CAROLINA, P.C.  
 343 E. Six Forks Road, Suite 200  
 Raleigh, North Carolina 27609  
 NC License No: C-1554

APPROVED: *Helen Shyu*  
 DATE: 11/10/2021  
 SEAL  
 DOCUMENT NOT CONSIDERED FINAL  
 UNLESS ALL SIGNATURES COMPLETED

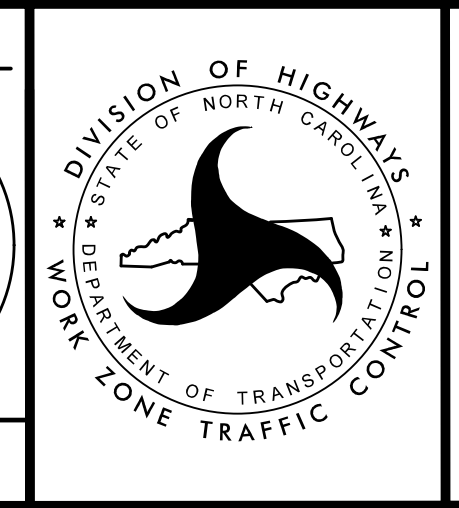

**TRANSPORTATION  
 MANAGEMENT PLAN**

**PHASE I  
 STEP 12.4  
 DETAIL**

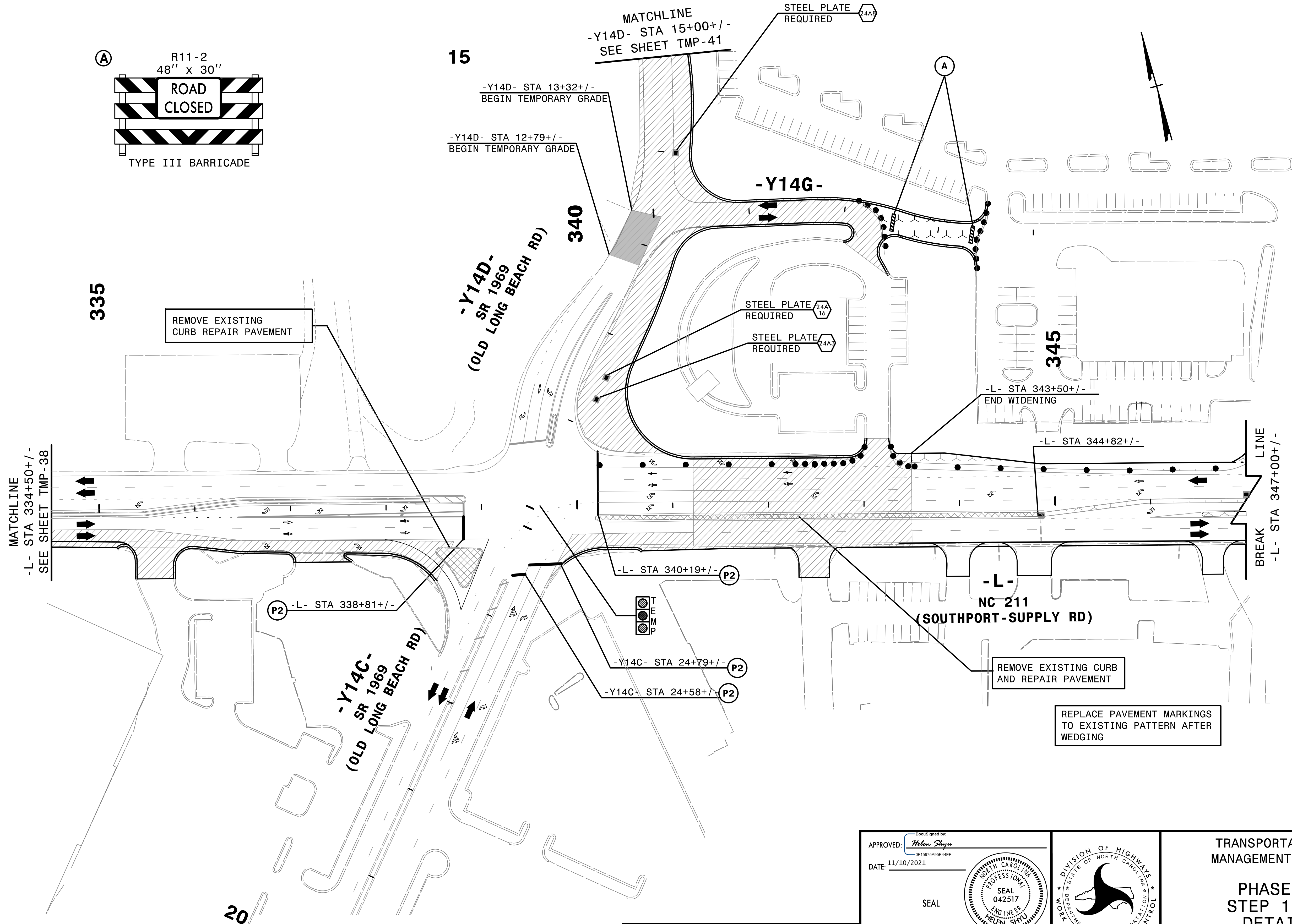
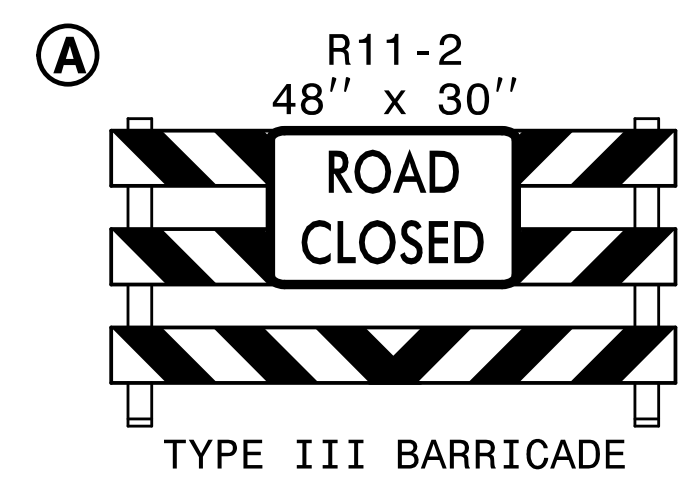

4:56:40 PM  
...\\TCN\5021\5021\to\_pid19\_detour.dgn  
\$\$\$\$\$USERNAME\$\$\$\$\$

**HNTB** HNTB NORTH CAROLINA, P.C.  
343 E. Six Forks Road, Suite 200  
Raleigh, North Carolina 27609  
NC License No: C-1554

APPROVED: *Helen Shyn*  
DATE: 11/10/2021

SEAL

DOCUMENT NOT CONSIDERED FINAL  
UNLESS ALL SIGNATURES COMPLETED

TRANSPORTATION  
MANAGEMENT PLAN

PHASE I  
STEP 12.4  
DETAIL



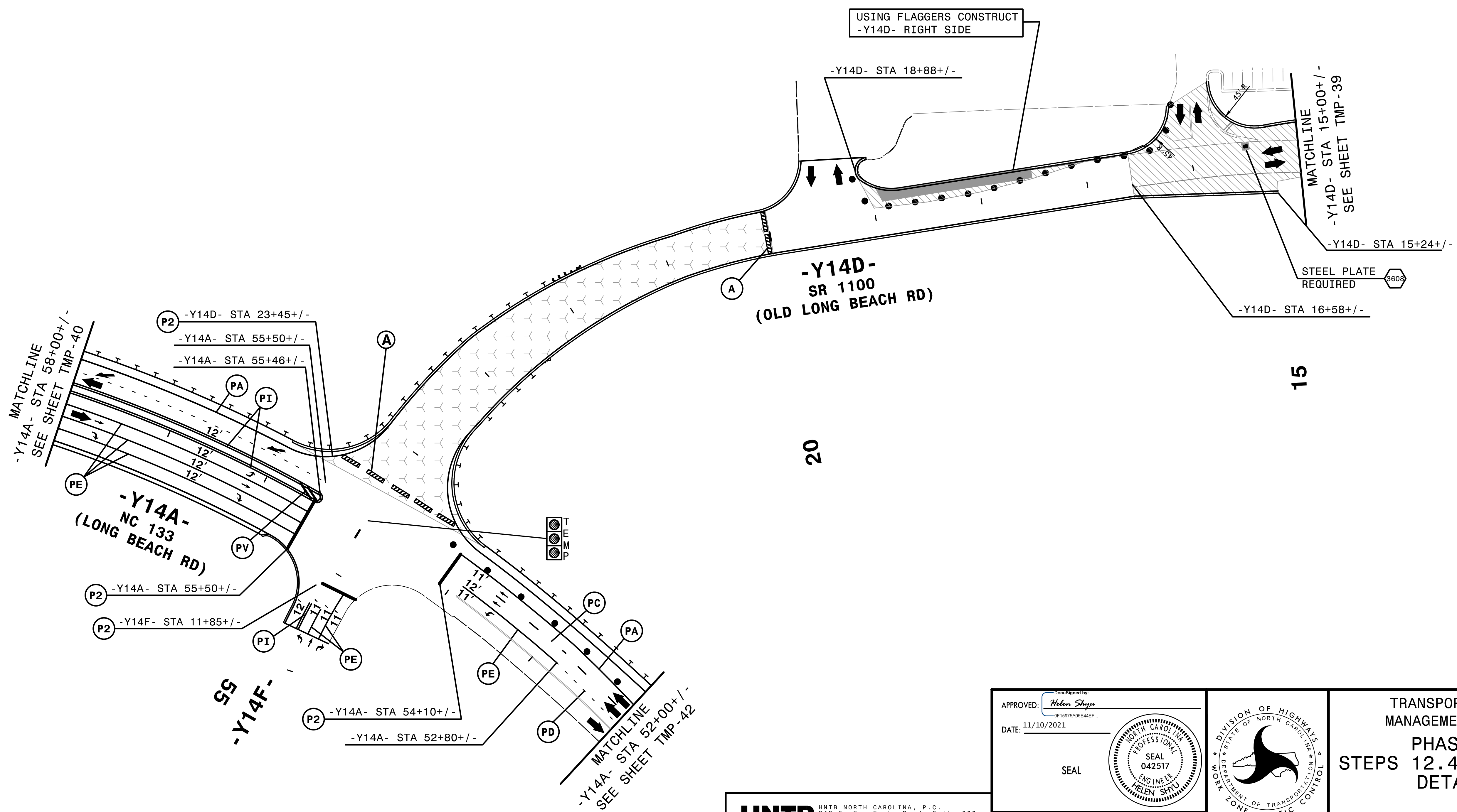
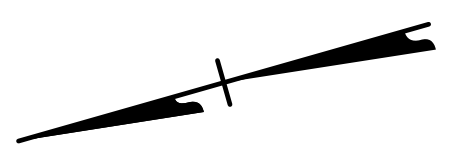
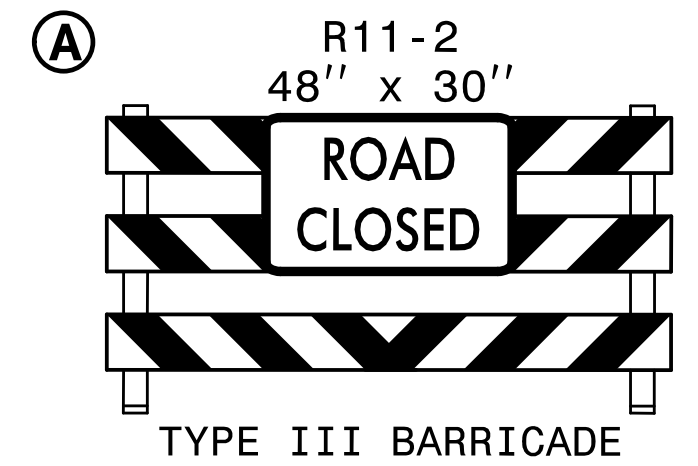

4:56:45 PM  
\\TCF\...5021\...pid35 detour.dgn  
\$\$\$USERNAME\$\$\$

**HNTB** HNTB NORTH CAROLINA, P.C.  
343 E. Six Forks Road, Suite 200  
Raleigh, North Carolina 27609  
NC License No: C-1554

APPROVED: *Helen Shyu*  
DATE: 11/10/2021

SEAL

TRANSPORTATION  
MANAGEMENT PLAN  
PHASE I  
STEPS 12.4 AND 12.6  
DETAIL



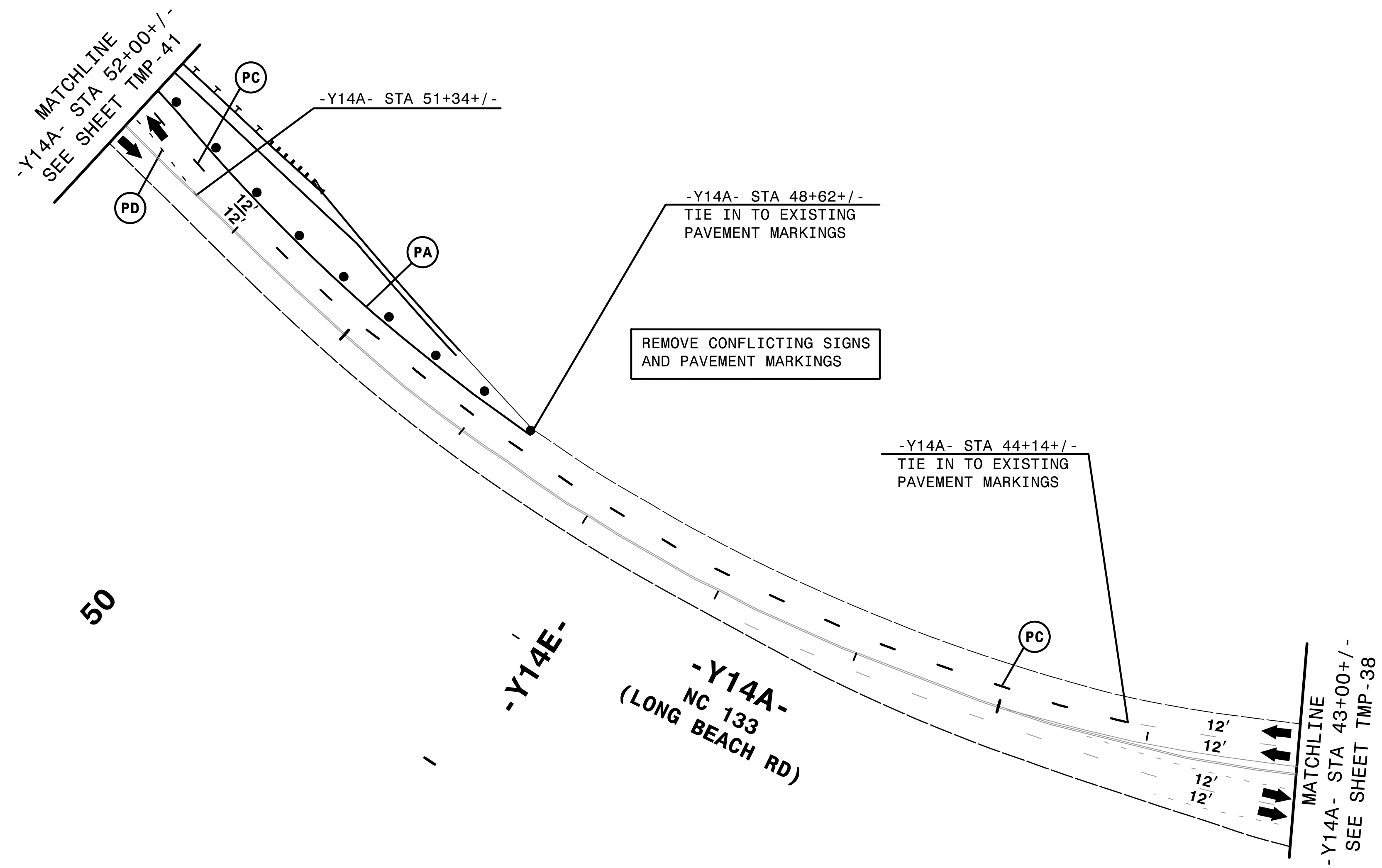
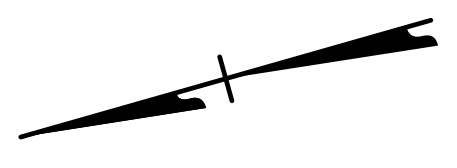

4:56:17 PM  
 \\TCF\5021\TC\_pid33\_detour.dgn  
 \$\$\$USERNAME\$\$\$

**HNTB** HNTB NORTH CAROLINA, P.C.  
 343 E. Six Forks Road, Suite 200  
 Raleigh, North Carolina 27609  
 NC License No: C-1554

APPROVED: *Helen Shyu*  
 DATE: 11/10/2021  
 SEAL  
 DOCUMENT NOT CONSIDERED FINAL  
 UNLESS ALL SIGNATURES COMPLETED

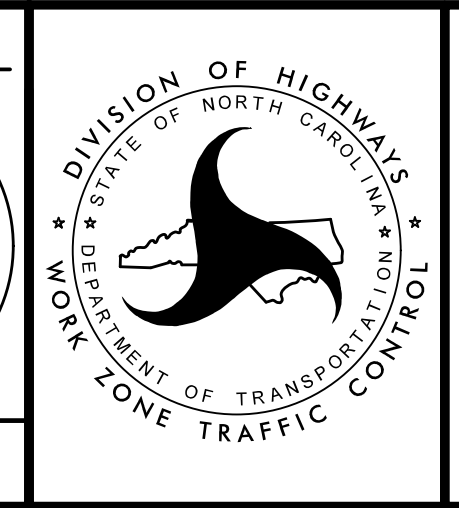

TRANSPORTATION  
 MANAGEMENT PLAN  
 PHASE I  
 STEPS 12.6  
 DETAIL

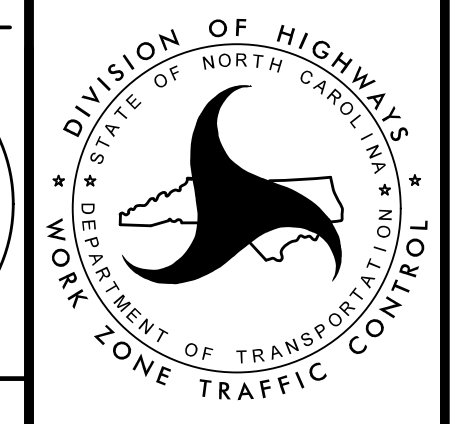

PROJ. REFERENCE NO.	SHEET NO.
R-5021	TMP-43

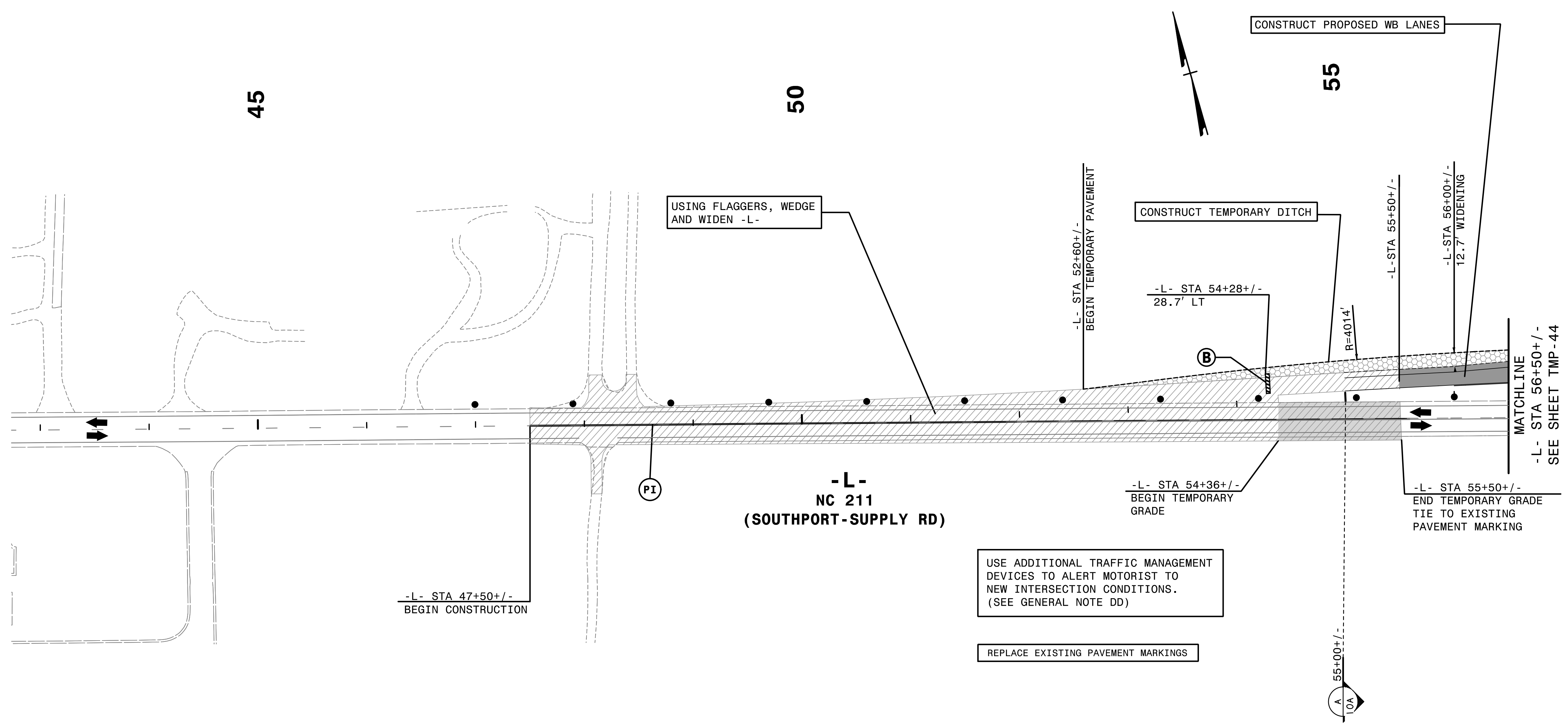

2/6/2019  
 TCR\5021\TC\_pidia.dgn  
 HNTB

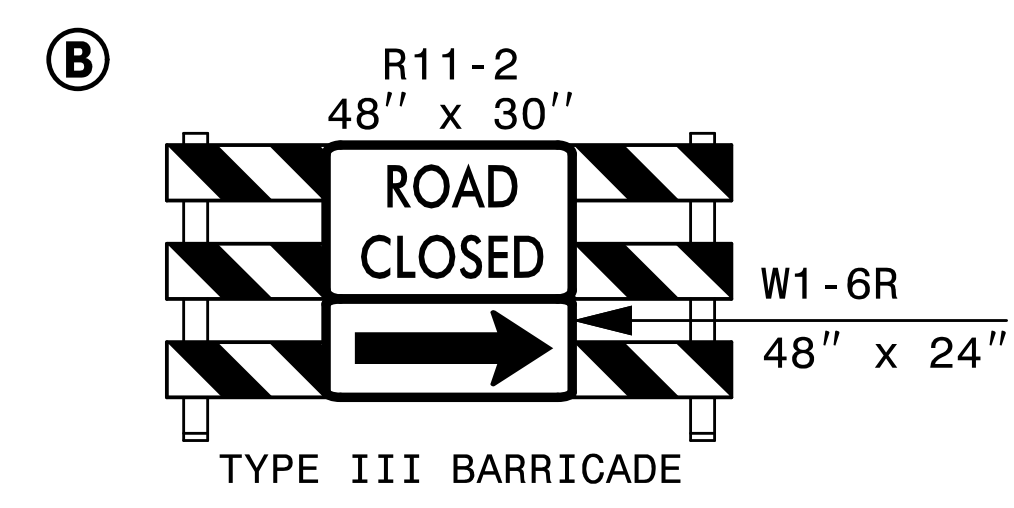

**HNTB**  
 HNTB NORTH CAROLINA, P.C.  
 343 E. Six Forks Road, Suite 200  
 Raleigh, North Carolina 27609  
 NC License No: C-1554

APPROVED: *Helen Skyy*  
 DATE: 2/6/2019  
 SEAL  
 PROFESSIONAL SEAL  
 042517  
 ENGINEER  
 HELEN SKYY

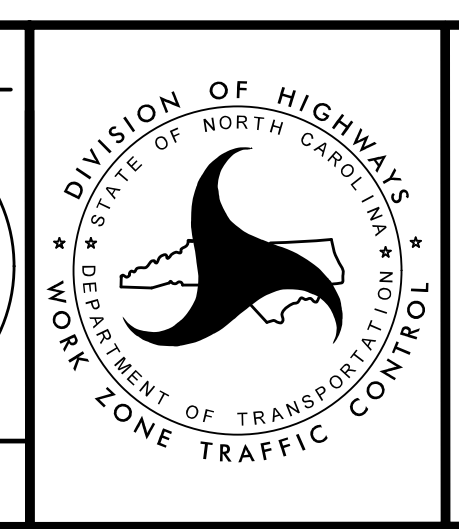

TRANSPORTATION  
 MANAGEMENT PLAN  
 PHASE IA  
 DETAIL

DOCUMENT NOT CONSIDERED FINAL  
 UNLESS ALL SIGNATURES COMPLETED

(X) 73' SHOP CURVED TEMPORARY GUARDRAIL WITH B-77 ANCHOR TO PCB AND TEMP AT-1

(Y) 73' SHOP CURVED TEMPORARY GUARDRAIL WITH B-77 ANCHOR TO PCB AND TEMP AT-1

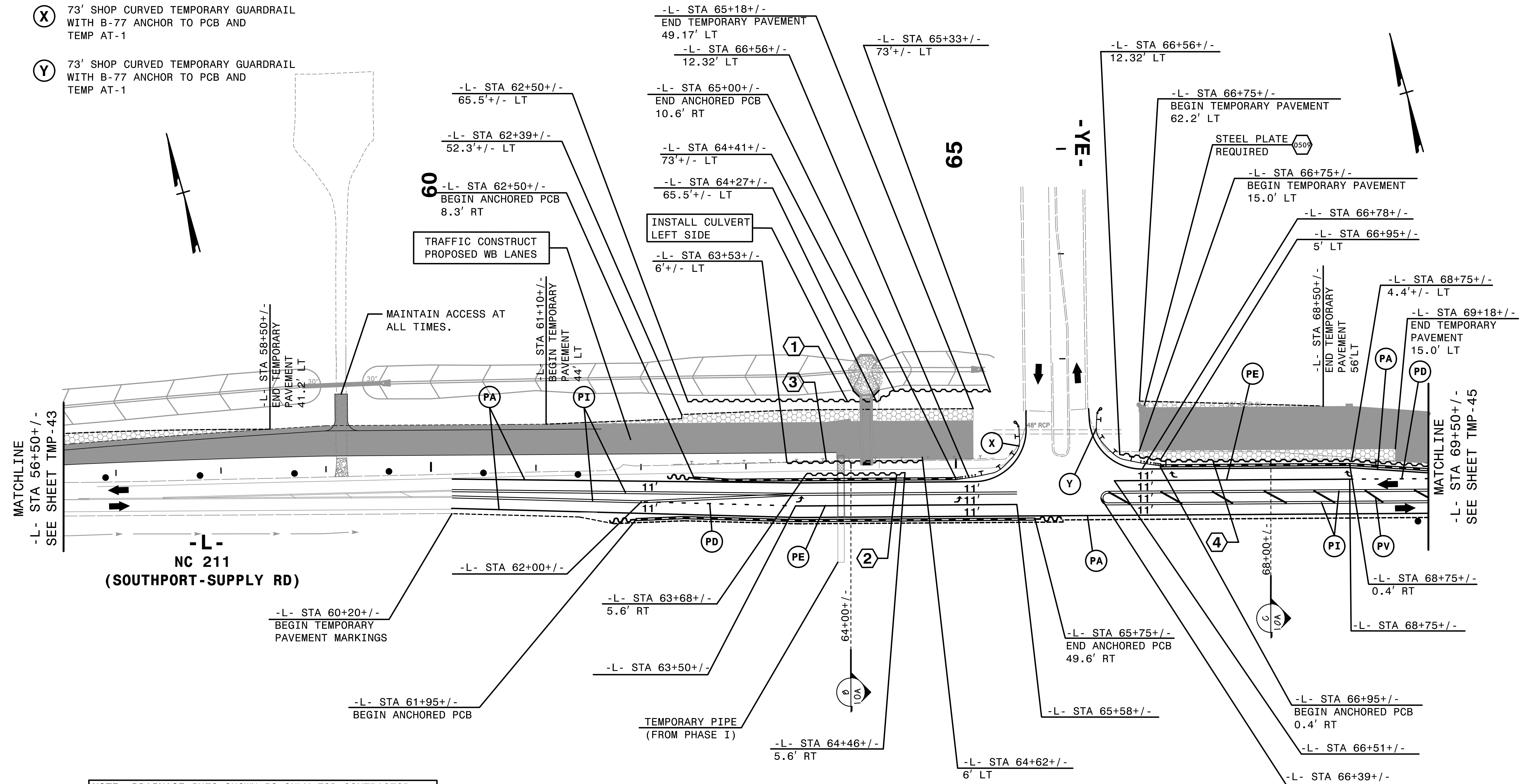

MATCHLINE  
-L- STA 56+50+/-  
SEE SHEET TMP-43

NC 211  
(SOUTHPORT-SUPPLY RD)

MATCHLINE  
-L- STA 69+50+/-  
SEE SHEET TMP-45

NOTE: DRAINAGE INFO SHOWN IS ONLY FOR CONTRACTOR CONSIDERATION. CONTRACTOR SHOULD VERIFY THAT PONDING OF WATER WILL NOT OCCUR IN THE TRAVEL LANES.

SEE CULVERT PHASING ON 5A/CONST.5

1 EST QUANTITY = 701.5 SF

TEMPORARY SHORING  
FROM -L- STA 62+50+/-, 65.5'+/- LT,  
TO -L- STA 64+27+/-, 65.5'+/- LT AND  
FROM -L- STA 64+27+/-, 65.5'+/- LT,  
TO -L- STA 64+41+/-, 73'+/- LT AND  
FROM -L- STA 64+41+/-, 73'+/- LT,  
TO -L- STA 65+33+/-, 73'+/- LT

(SEE SHEET TMP-2G FOR  
TEMPORARY SHORING NOTES)

2 EST QUANTITY = 400 SF

TEMPORARY SHORING  
FROM -L- STA 63+68+/-, 5.6'+/- RT,  
TO -L- STA 64+46+/-, 5.6'+/- RT

3 EST QUANTITY = 885 SF

TEMPORARY SHORING  
FROM -L- STA 63+53+/-, 6'+/- LT,  
TO -L- STA 64+62+/-, 6'+/- LT

4 EST QUANTITY = 2118 SF

TEMPORARY SHORING  
FROM -L- STA 66+56+/-, 12.32'+/- LT,  
TO -L- STA 67+00+/-, 5'+/- LT AND  
FROM -L- STA 67+00+/-, 5'+/- LT,  
TO -L- STA 68+75+/-, 4.4'+/- LT AND  
FROM -L- STA 68+75+/-, 4.4'+/- LT,  
TO -L- STA 70+13+/-, 5.67'+/- RT

REMOVE CONFLICTING PAVEMENT MARKING.

4:56:21PM  
\\TCFV\5021\TC\pld2a.dgn  
\$\$\$\$\$USERNAME\$\$\$\$\$

**HNTB** HNTB NORTH CAROLINA, P.C.  
343 E. Six Forks Road, Suite 200  
Raleigh, North Carolina 27609  
NC License No: C-1554

APPROVED: *Helen Shyu*  
DATE: 11/10/2021  
SEAL  
HNTB NORTH CAROLINA, P.C.  
PROFESSIONAL ENGINEER  
SEAL 042517  
HELEN SHYU

DIVISION OF HIGHWAYS  
STATE OF NORTH CAROLINA  
DEPARTMENT OF TRANSPORTATION  
WORK ZONE TRAFFIC CONTROL

TRANSPORTATION  
MANAGEMENT PLAN  
  
PHASE IA  
DETAIL

DOCUMENT NOT CONSIDERED FINAL  
UNLESS ALL SIGNATURES COMPLETED

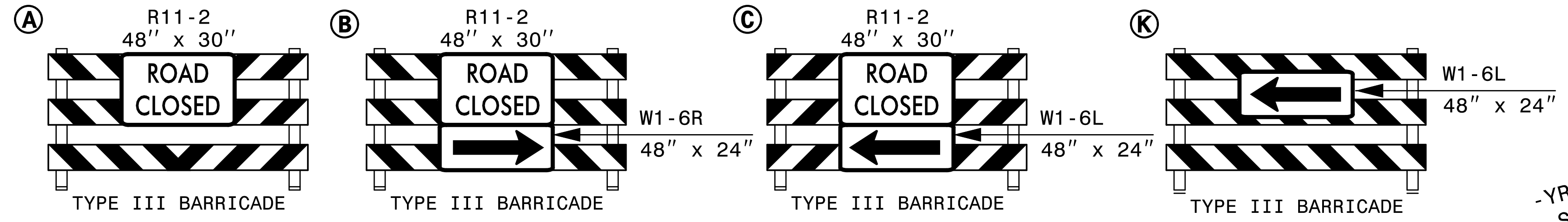

REMOVE CONFLICTING PAVEMENT MARKING.

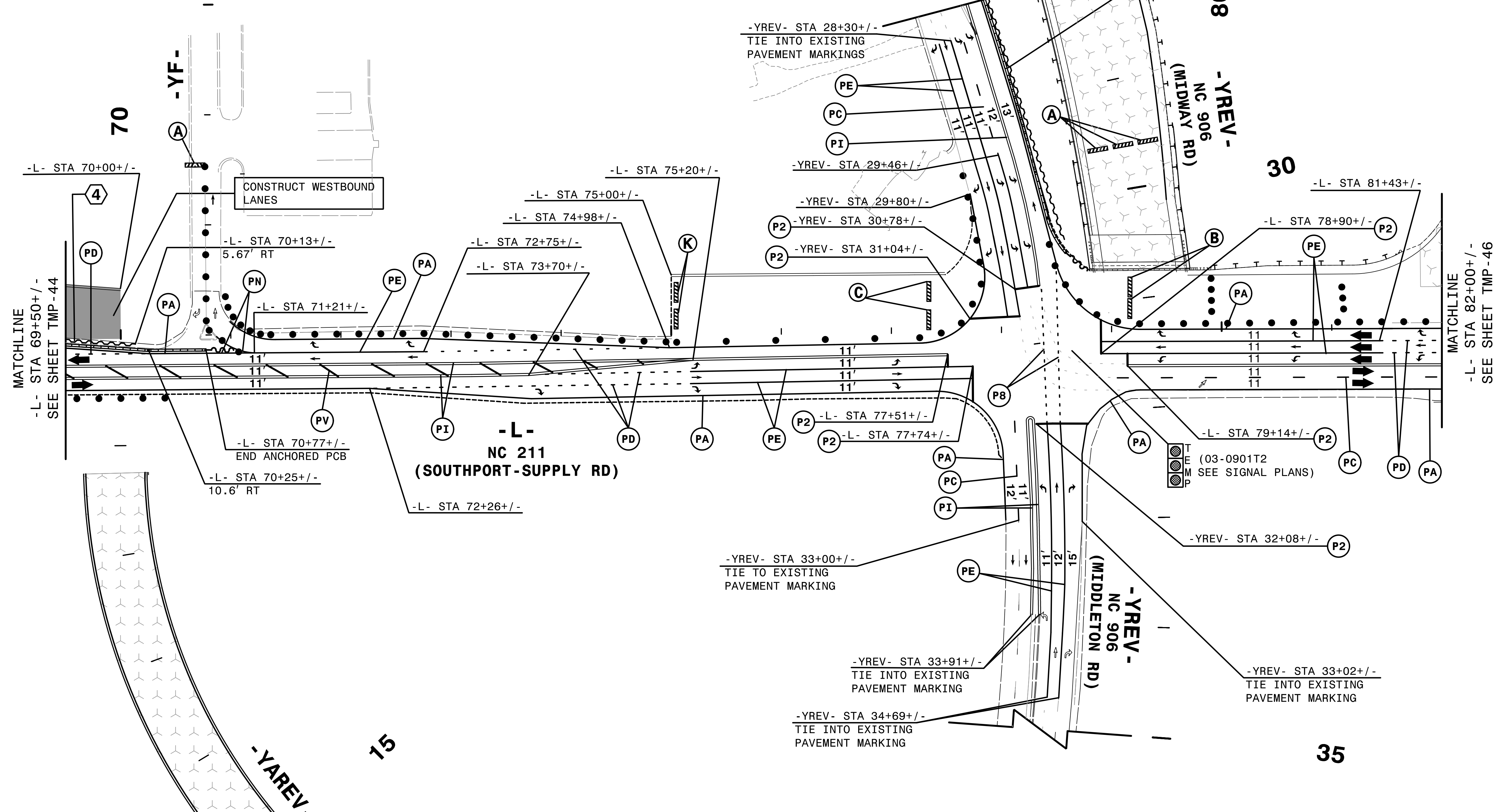
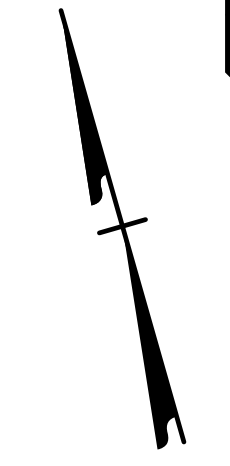

**4** EST QUANTITY = 2118 SF

TEMPORARY SHORING  
 FROM -L- STA 66+56+/-, 12.32'+/- LT,  
 TO -L- STA 67+00+/-, 5'+/- LT AND  
 FROM -L- STA 67+00+/-, 5'+/- LT,  
 TO -L- STA 68+75+/-, 4.4'+/- LT AND  
 FROM -L- STA 68+75+/-, 4.4'+/- LT,  
 TO -L- STA 70+03+/-, 5.67'+/- RT

(SEE SHEET TMP-2G FOR  
 TEMPORARY SHORING NOTES)

3:23:14 PM  
C:\Users\5021\Documents\5021\Tc\p1d3a.dgn  
\$\$\$\$\$USERNAME\$\$\$\$\$

**HNTB** HNTB NORTH CAROLINA, P.C.  
 343 E. Six Forks Road, Suite 200  
 Raleigh, North Carolina 27609  
 NC License No: C-1554

APPROVED: *Helen Shyu*  
DE 15975A95E4AEF

DATE: 10/28/2021

SEAL

DOCUMENT NOT CONSIDERED FINAL  
 UNLESS ALL SIGNATURES COMPLETED

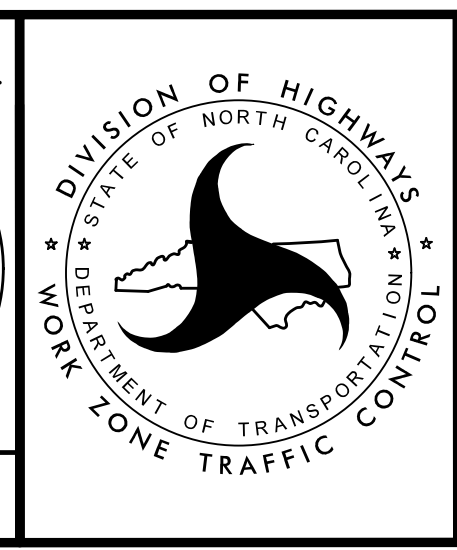

TRANSPORTATION  
 MANAGEMENT PLAN

PHASE IA  
 DETAIL

SEAL

SEAL

NOTE: DRAINAGE INFO SHOWN IS ONLY FOR CONTRACTOR CONSIDERATION. CONTRACTOR SHOULD VERIFY THAT PONDING OF WATER WILL NOT OCCUR IN THE TRAVEL LANES.

REMOVE CONFLICTING PAVEMENT MARKING.

SEE CULVERT PHASING ON EC-6A/CONST. 6

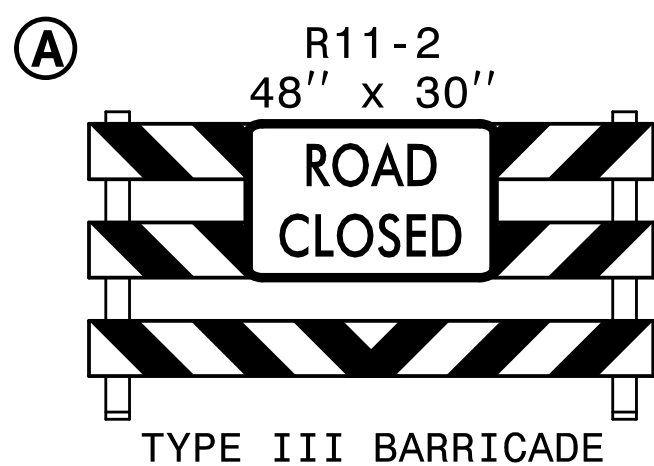
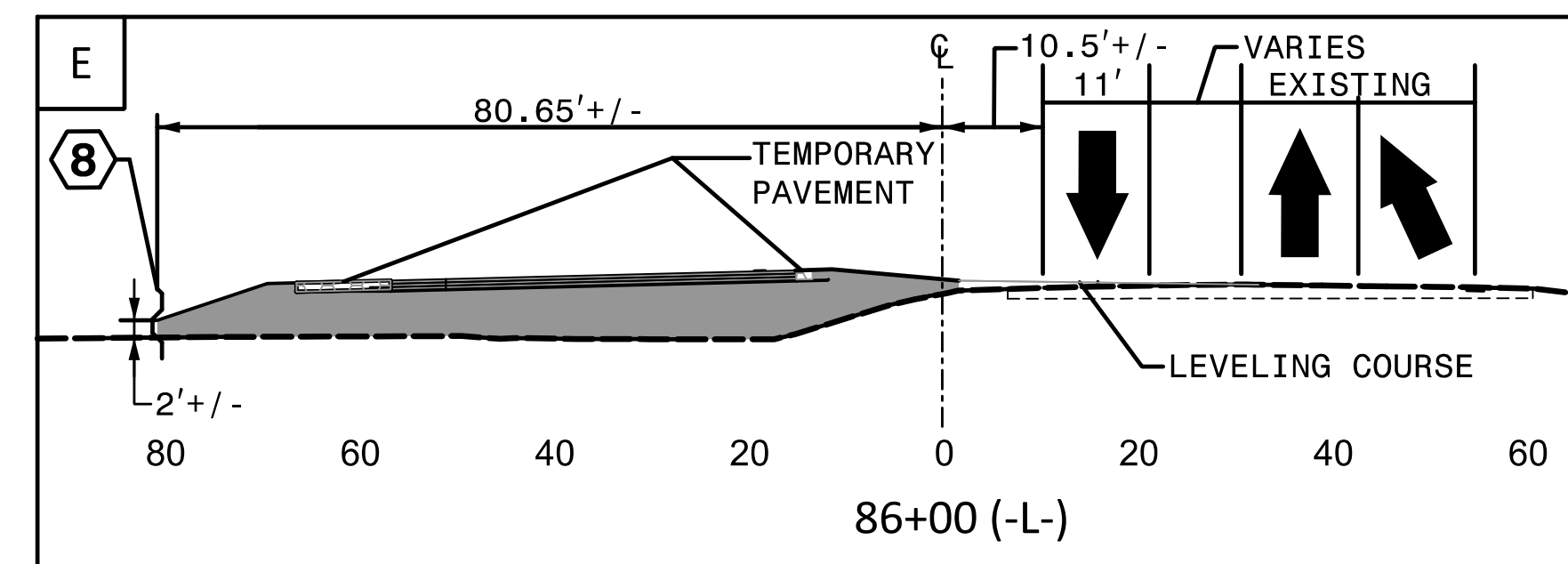
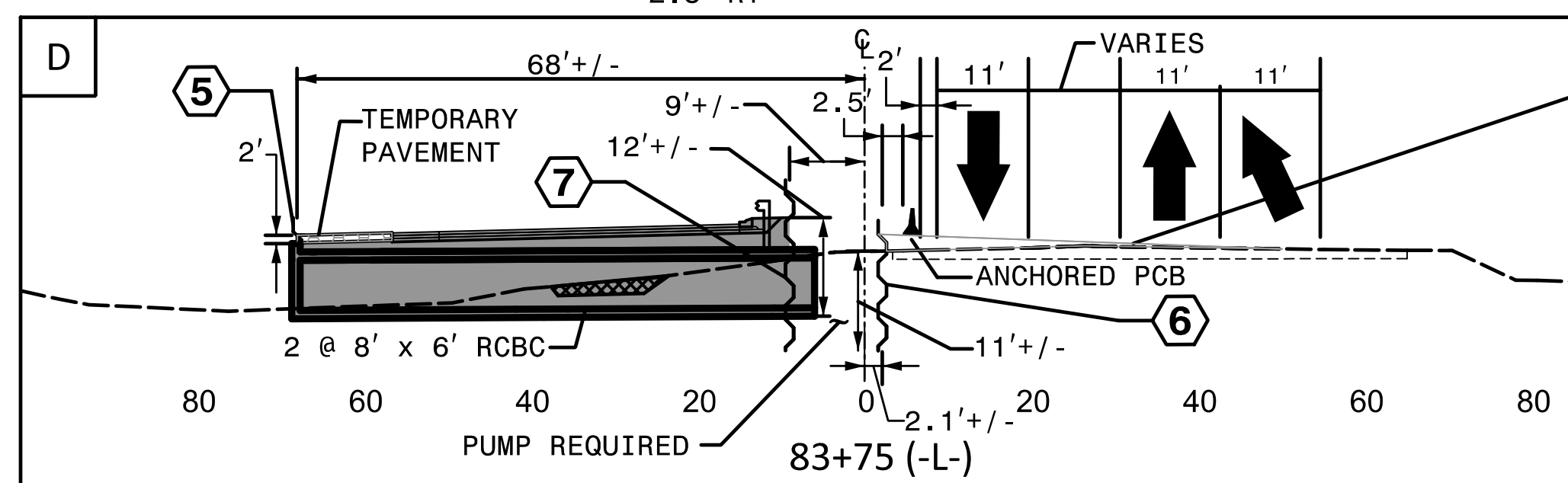
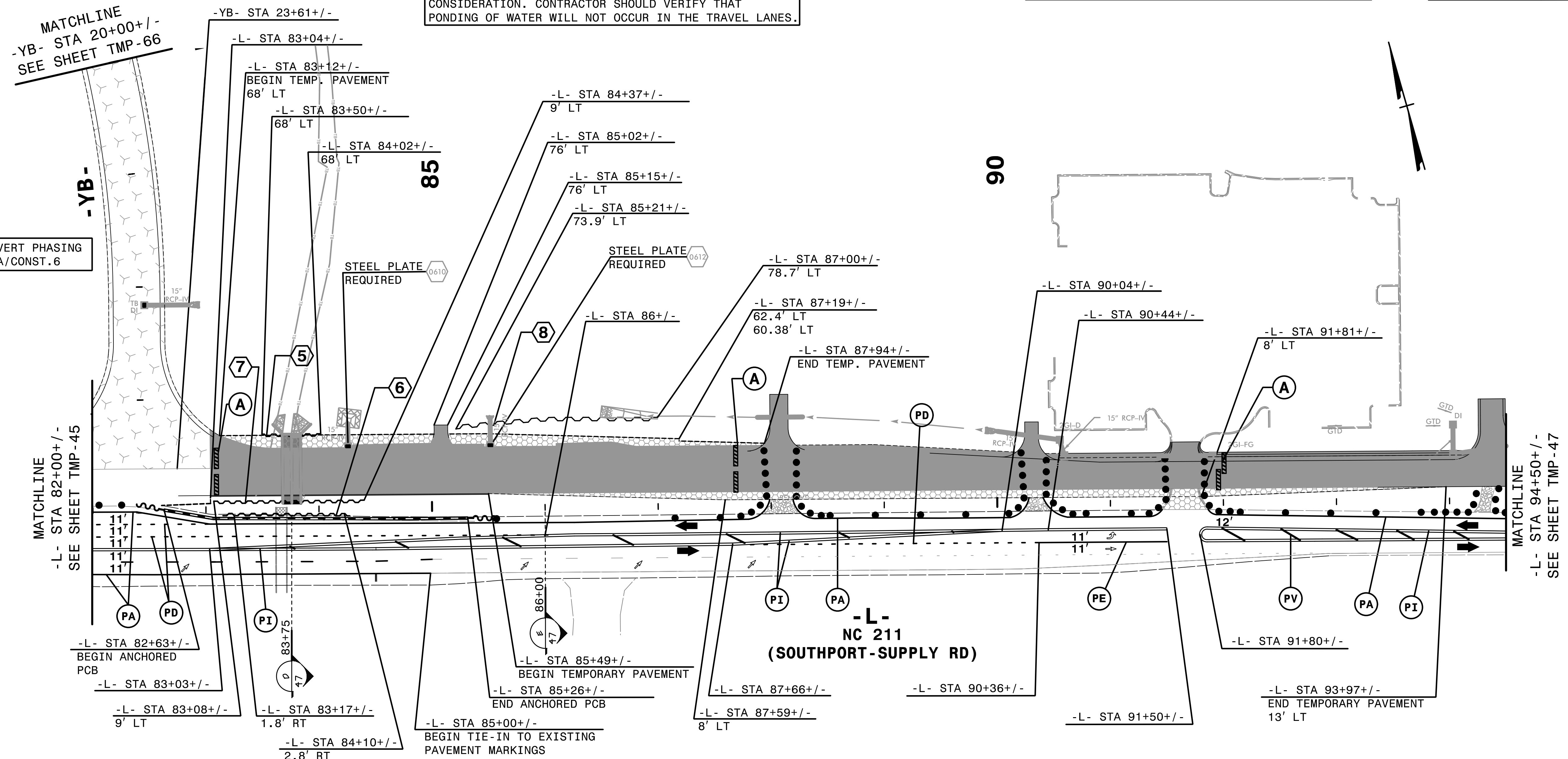

**5** EST QUANTITY = 104 SF  
 TEMPORARY SHORING  
 FROM -L- STA 83+50+/-, 68' LT,  
 TO -L- STA 84+02+/-, 68' LT.  
 (SEE SHEET TMP-2G FOR  
 TEMPORARY SHORING NOTES)

**6** EST QUANTITY = 660 SF  
 TEMPORARY SHORING  
 FROM -L- STA 83+17+/-, 1.8' RT,  
 TO -L- STA 84+10+/-, 2.8' RT.  
**7** EST QUANTITY = 1296 SF  
 TEMPORARY SHORING  
 FROM -L- STA 83+08+/-, 9' LT,  
 TO -L- STA 84+37+/-, 9' LT.

**8** EST QUANTITY = 383.06 SF  
 TEMPORARY SHORING  
 FROM -L- STA 85+21+/-, 73.9' LT,  
 TO -L- STA 86+00+/-, 80.7' LT,  
 FROM -L- STA 86+00+/-, 80.7' LT,  
 TO -L- STA 87+00+/-, 78.7' LT.



APPROVED: *Helen Shyne*  
 DATE: 9/9/2021  
 SEAL  
 DOCUMENT NOT CONSIDERED FINAL  
 UNLESS ALL SIGNATURES COMPLETED

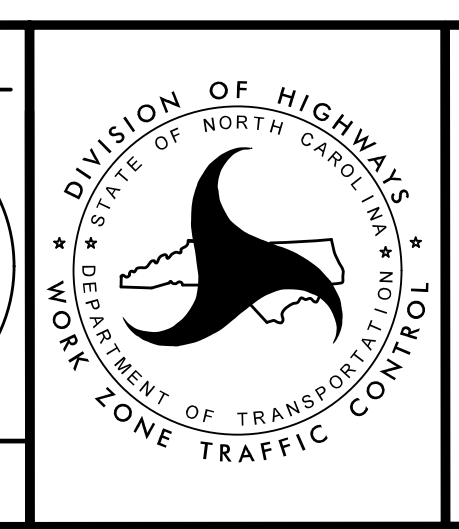

TRANSPORTATION  
 MANAGEMENT PLAN  
 PHASE IA  
 DETAIL

4:52:50 PM  
 ...\\TCPLV5021...\_TC...\_p1d4a.dgn  
 \$\$\$USERNAME\$\$\$

REMOVE CONFLICTING PAVEMENT MARKING.

PROJ. REFERENCE NO.	SHEET NO.
R-5021	TMP-47

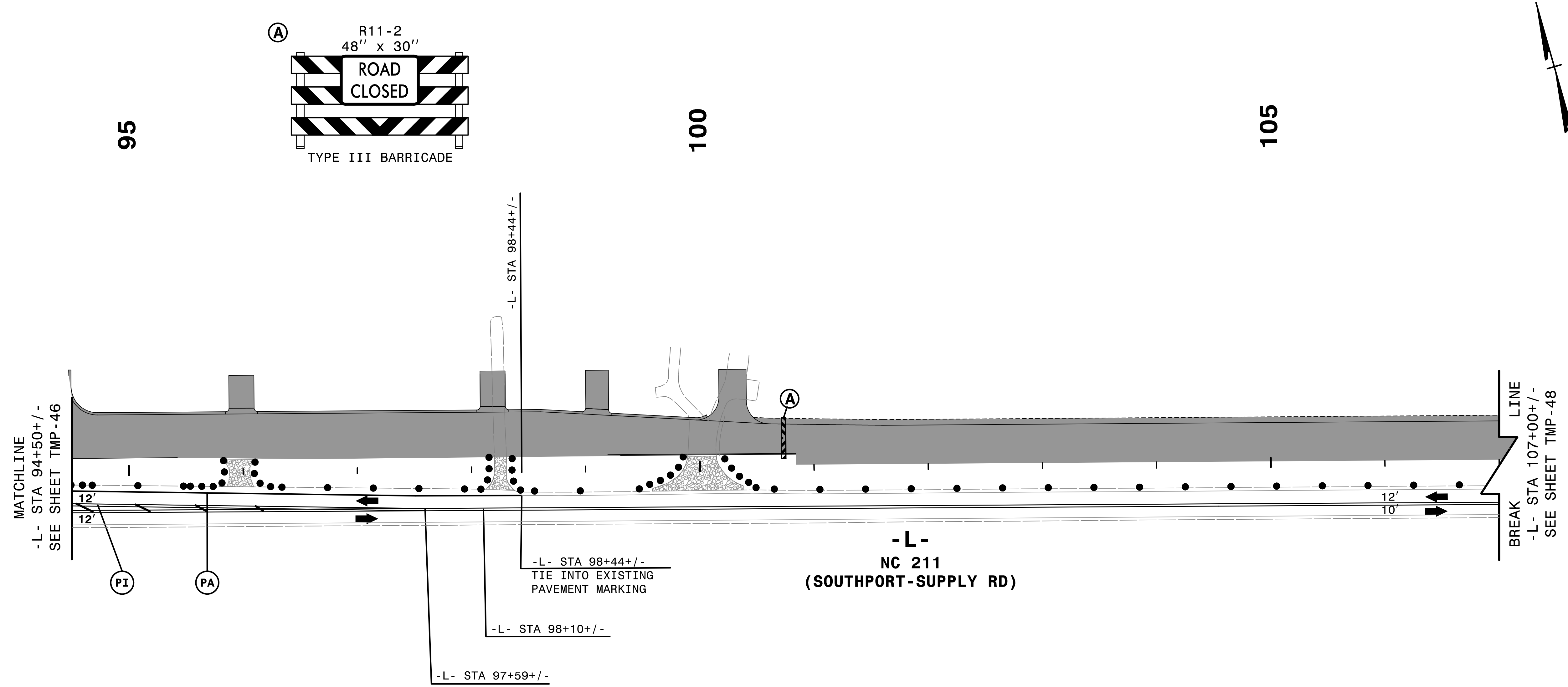

4:52:54 PM  
...\\TC\...5021\_Tc\_pld\ba.dgn  
\$\$\$\$\$USERNAME\$\$\$\$\$

**HNTB** HNTB NORTH CAROLINA, P.C.  
343 E. Six Forks Road, Suite 200  
Raleigh, North Carolina 27609  
NC License No: C-1554

APPROVED: *Helen Shyu*  
DATE: 9/9/2021  
SEAL  
DOCUMENT NOT CONSIDERED FINAL  
UNLESS ALL SIGNATURES COMPLETED

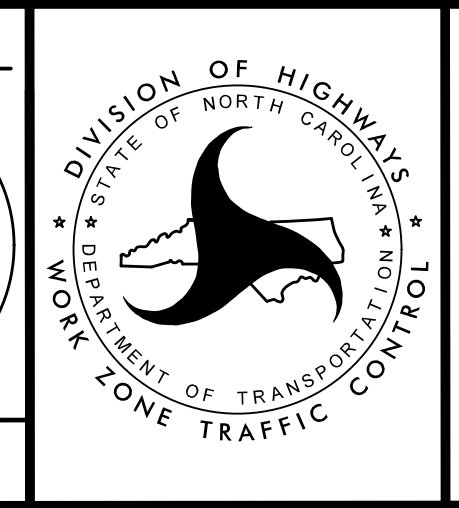
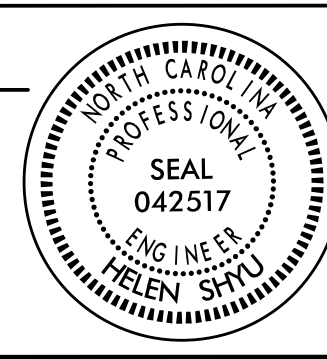

TRANSPORTATION  
MANAGEMENT PLAN  
  
PHASE IA  
DETAIL

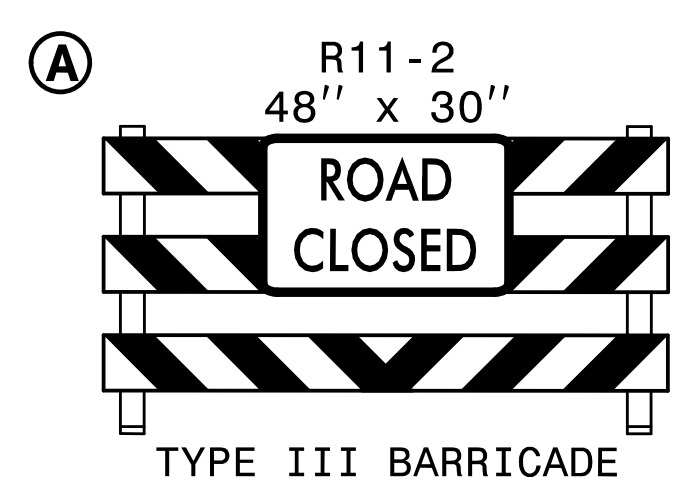

REMOVE CONFLICTING PAVEMENT MARKING.

PROJ. REFERENCE NO.	SHEET NO.
R-5021	TMP-48

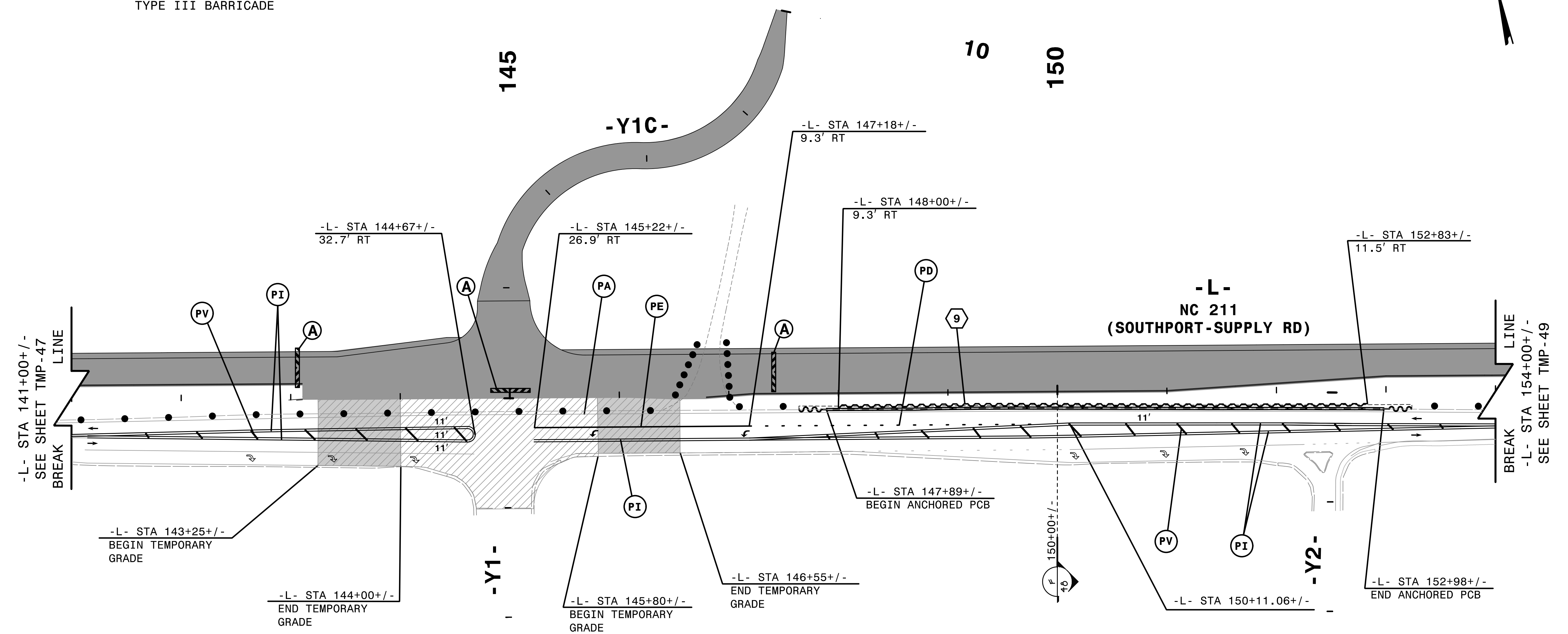

9 EST QUANTITY = 2584.05 SF  
 TEMPORARY SHORING  
 FROM -L- STA 148+00+/-, 9.3' LT  
 TO -L- STA 152+83+/-, 11.5' LT  
 (SEE SHEET TMP-2G FOR  
 TEMPORARY SHORING NOTES)

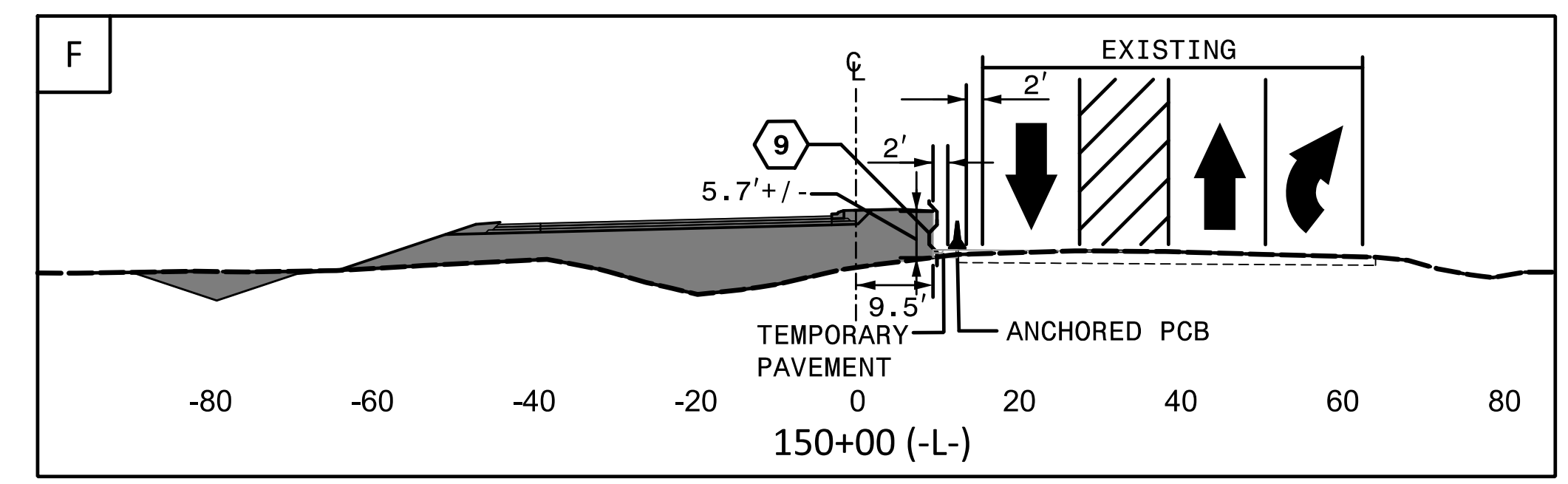

2/6/2019  
HNTB

**HNTB**  
 HNTB NORTH CAROLINA, P.C.  
 343 E. Six Forks Road, Suite 200  
 Raleigh, North Carolina 27609  
 NC License No: C-1554

APPROVED: *Helen Shyu*  
 DATE: 2/6/2019  
 SEAL  
 PROFESSIONAL ENGINEER  
 SEAL 042517  
 HELEN SHYU

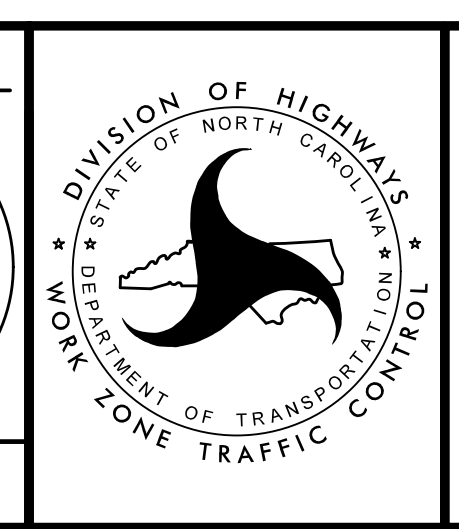

TRANSPORTATION  
 MANAGEMENT PLAN  
 PHASE IA  
 DETAIL

DOCUMENT NOT CONSIDERED FINAL  
UNLESS ALL SIGNATURES COMPLETED





PROJ. REFERENCE NO.	SHEET NO.
R-5021	TMP-50

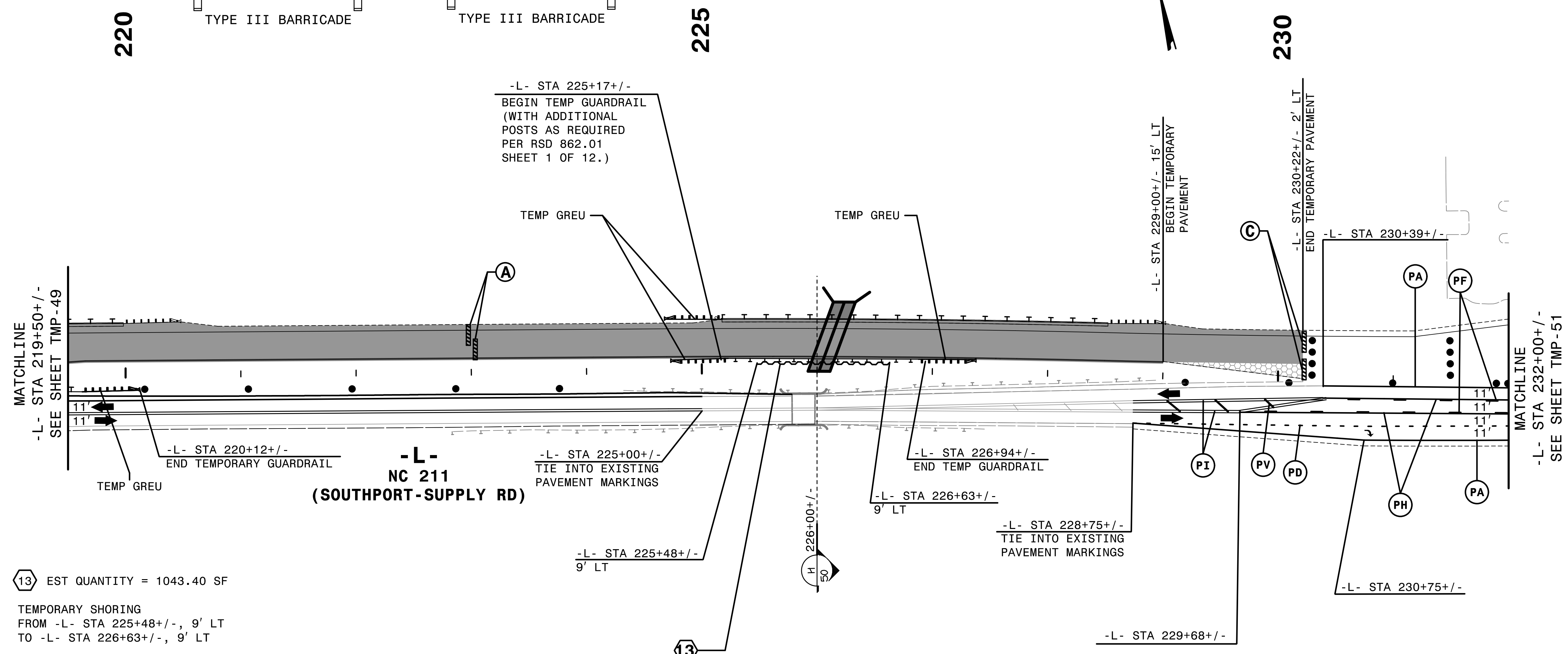
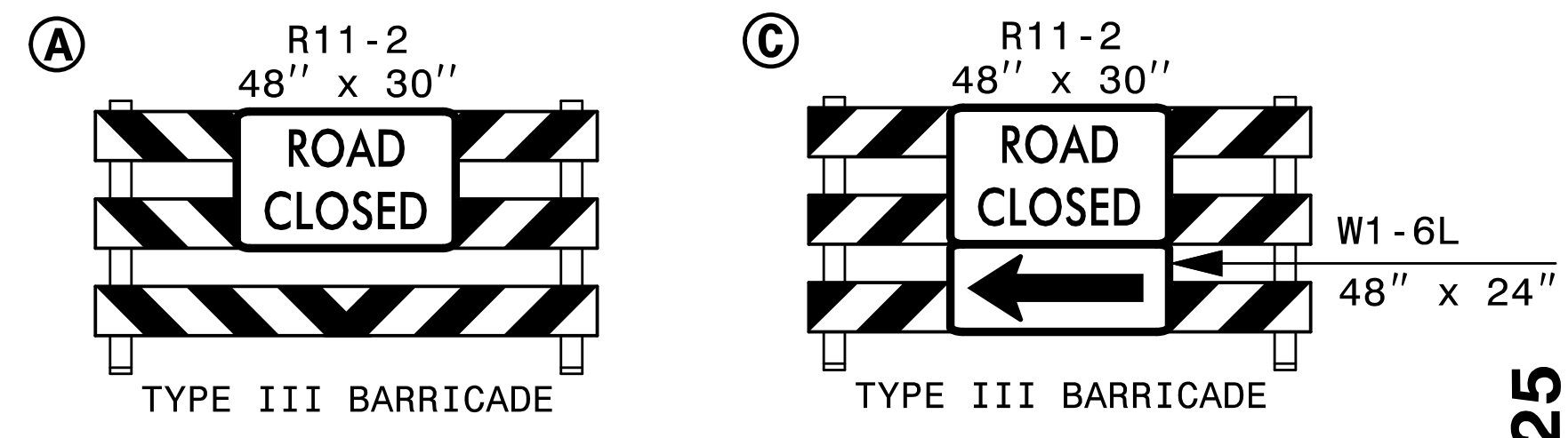

13 EST QUANTITY = 1043.40 SF  
 TEMPORARY SHORING  
 FROM -L- STA 225+48+/-, 9' LT  
 TO -L- STA 226+63+/-, 9' LT  
 (SEE SHEET TMP-2G FOR  
 TEMPORARY SHORING NOTES)

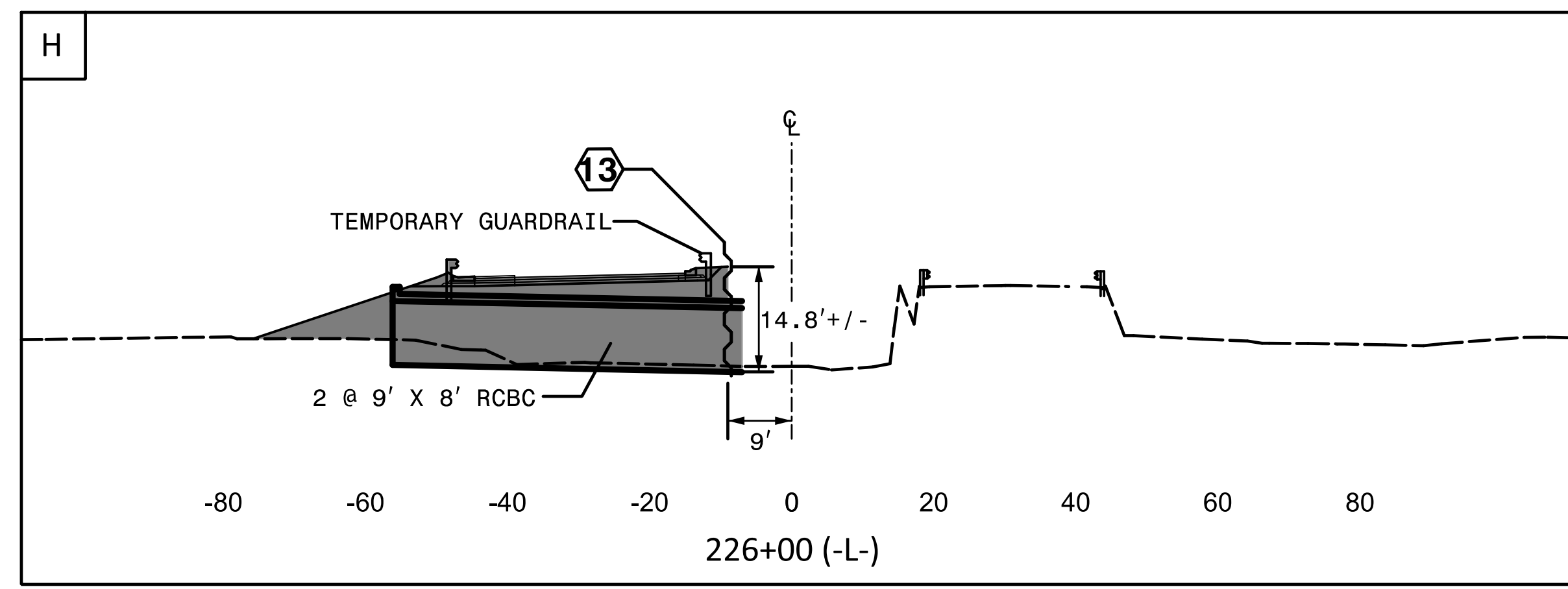

2/6/2019  
 HNTB  
 \CP\5021\Tc-pld10a.dgn

**HNTB**  
 HNTB NORTH CAROLINA, P.C.  
 343 E. Six Forks Road, Suite 200  
 Raleigh, North Carolina 27609  
 NC License No: C-1554

APPROVED: *Helen Skyy*  
 DATE: 2/6/2019  
 SEAL  
 PROFESSIONAL ENGINEER  
 HELEN SKYY  
 042517

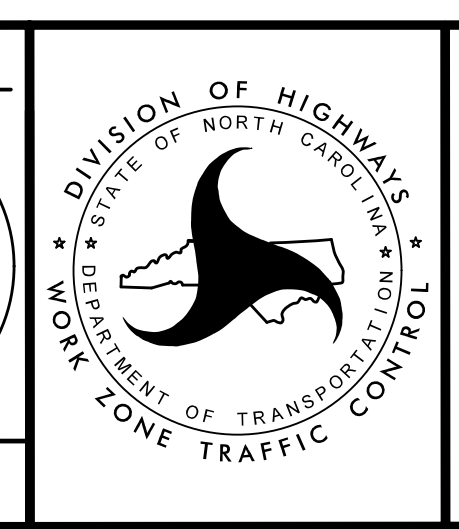

TRANSPORTATION  
 MANAGEMENT PLAN  
 PHASE IA  
 DETAIL

DOCUMENT NOT CONSIDERED FINAL  
 UNLESS ALL SIGNATURES COMPLETED

PROJ. REFERENCE NO.	SHEET NO.
R-5021	TMP-51

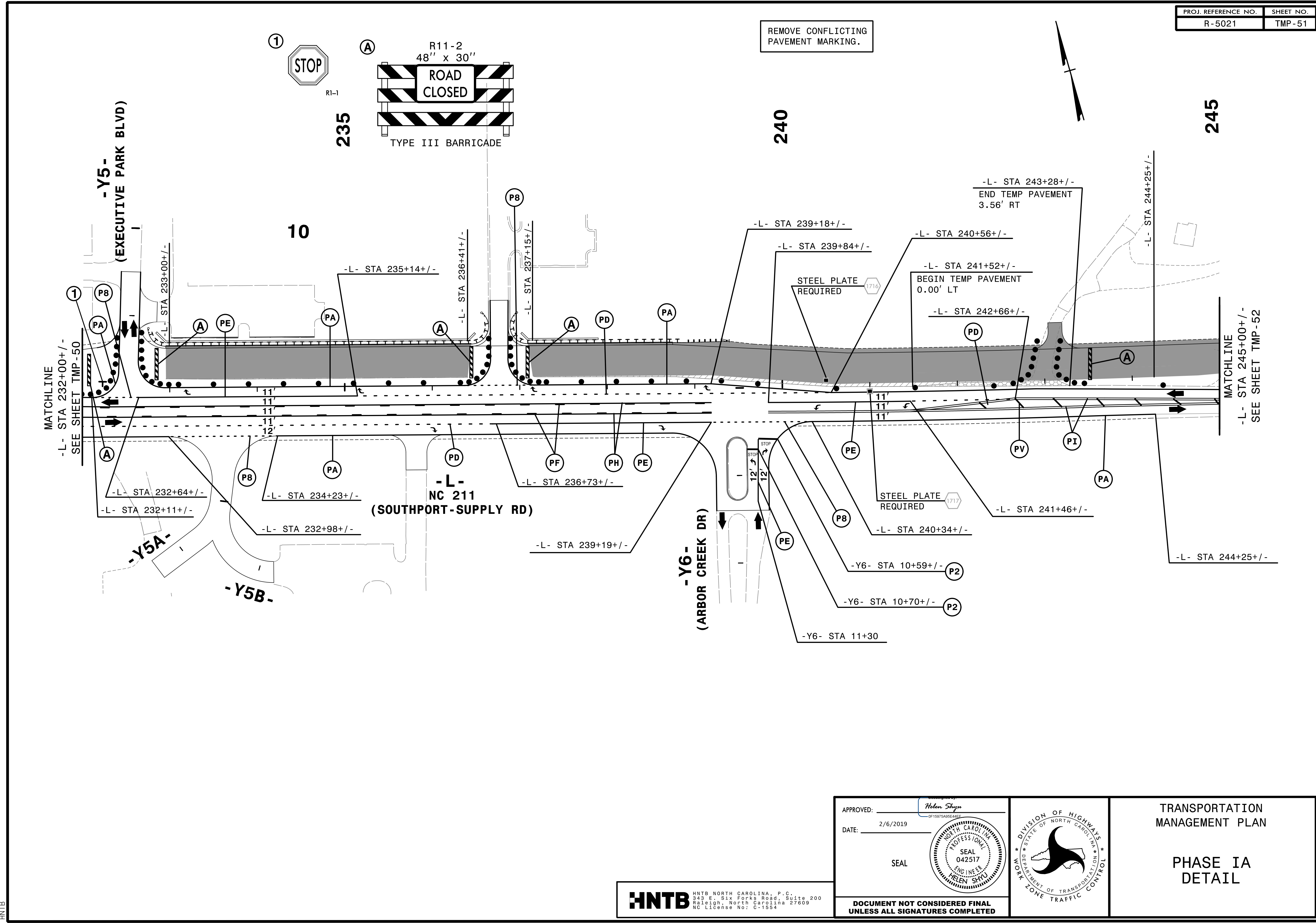

2/6/2019  
 C:\CPV\5021\TC\_pidla.dgn  
 HNTB

**HNTB** HNTB NORTH CAROLINA, P.C.  
 343 E. Six Forks Road, Suite 200  
 Raleigh, North Carolina 27609  
 NC License No: C-1554

APPROVED: *Helen Skyy*  
 DATE: 2/6/2019  
 SEAL  
 DOCUMENT NOT CONSIDERED FINAL  
 UNLESS ALL SIGNATURES COMPLETED

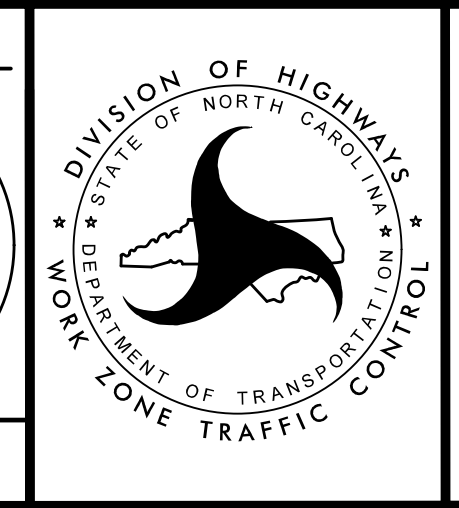

TRANSPORTATION  
 MANAGEMENT PLAN  
 PHASE IA  
 DETAIL

REMOVE CONFLICTING PAVEMENT MARKING.

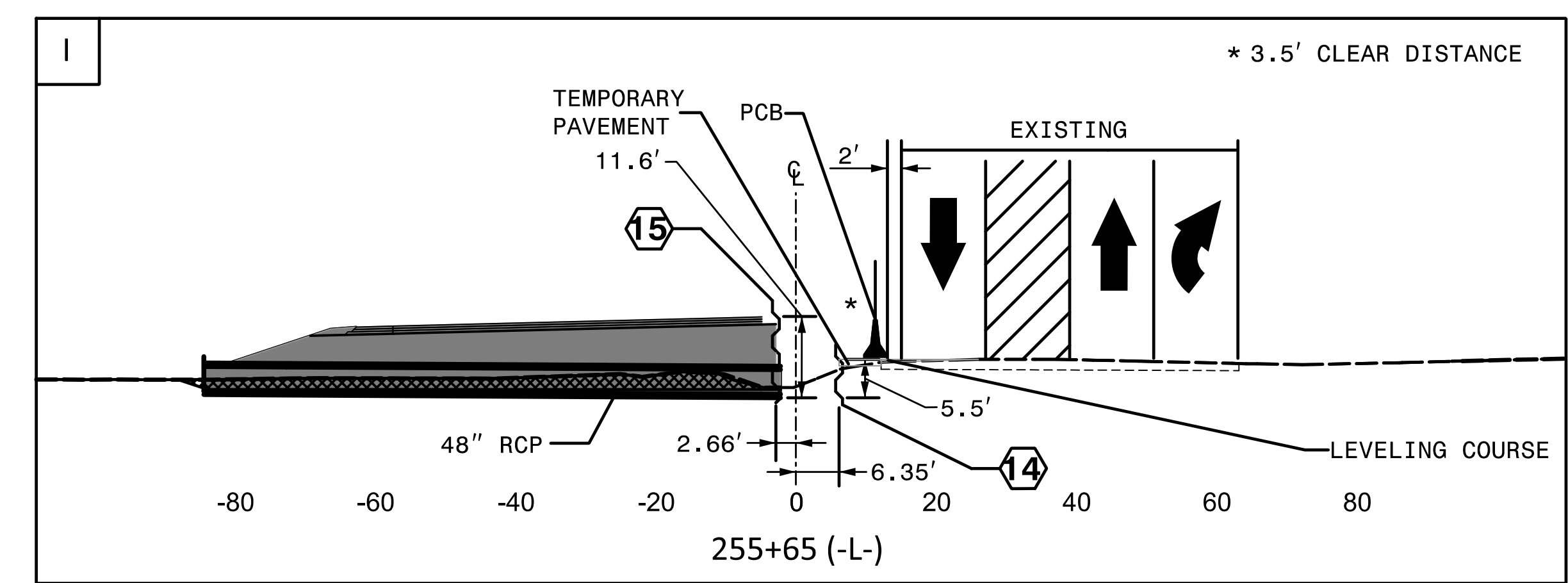
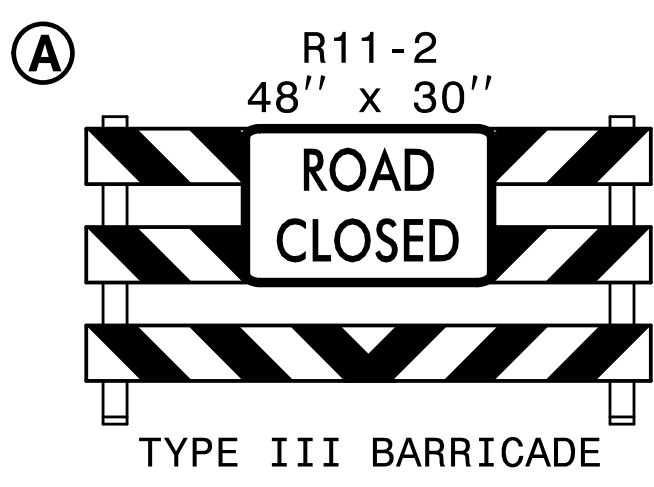
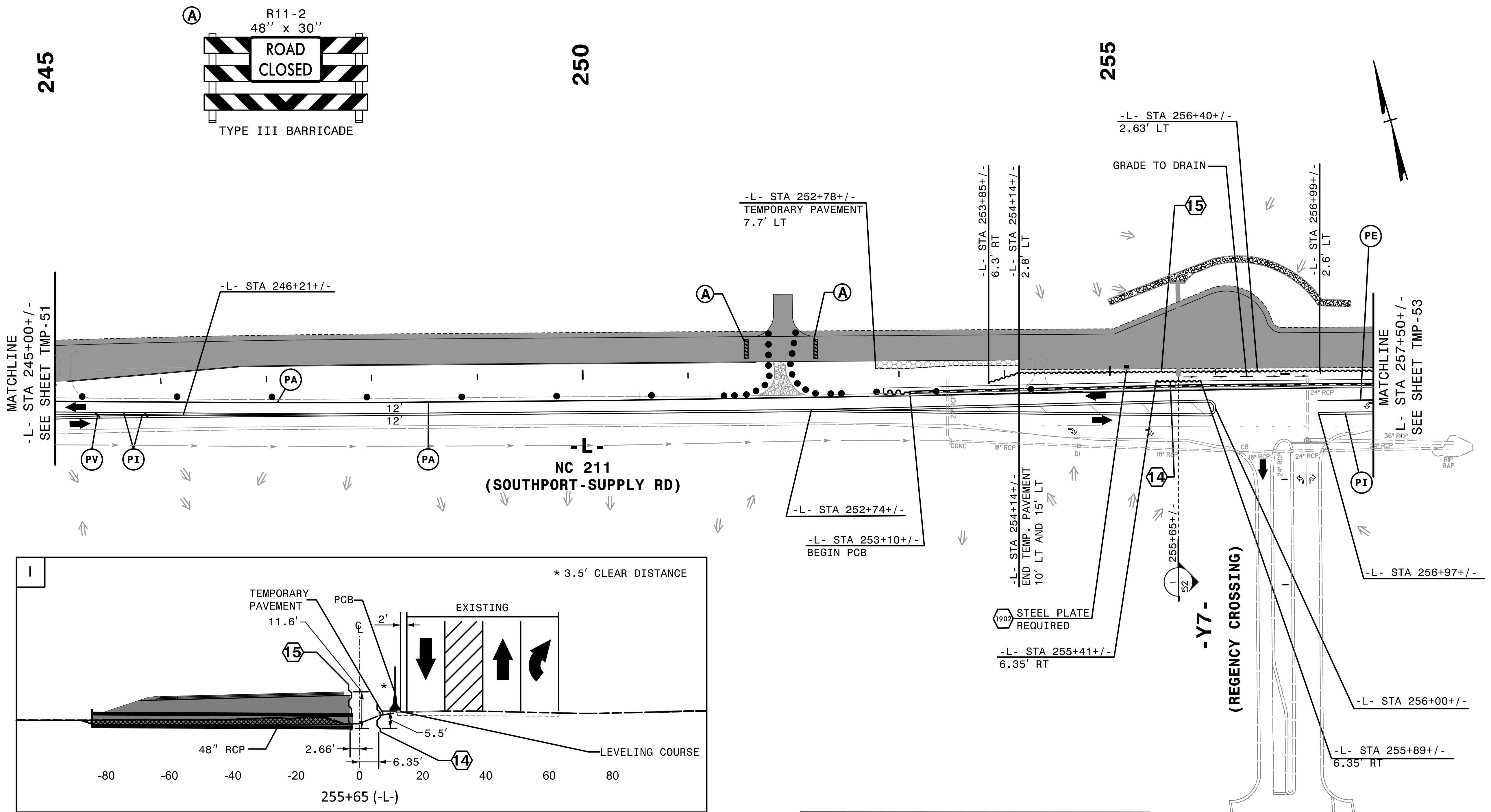

14 EST QUANTITY = 170.5 SF

TEMPORARY SHORING  
 FROM -L- STA 255+41+/-, 6.4' RT  
 TO -L- STA 255+89+/-, 6.4' RT

(SEE SHEET TMP-2G FOR  
 TEMPORARY SHORING NOTES)

15 EST QUANTITY = 8652.67 SF

TEMPORARY SHORING  
 FROM -L- STA 253+85+/-, 6.3' RT  
 TO -L- STA 254+14+/-, 2.8' LT AND  
 FROM -L- STA 254+14+/-, 2.8' LT  
 TO -L- STA 256+40+/-, 2.63' LT AND  
 FROM -L- STA 256+40+/-, 2.63' LT  
 TO -L- STA 256+99+/-, 2.6' LT AND  
 FROM -L- STA 256+99+/-, 2.6' LT  
 TO -L- STA 258+37+/-, 2.1' LT AND  
 FROM -L- STA 258+37+/-, 2.1' LT  
 TO -L- STA 260+12+/-, 0.3' LT AND  
 FROM -L- STA 260+12+/-, 0.3' LT  
 TO -L- STA 262+79+/-, 8.9' LT.

(SEE SHEET TMP-2G FOR  
 TEMPORARY SHORING NOTES)

NOTE: DRAINAGE INFO SHOWN IS ONLY FOR CONTRACTOR CONSIDERATION. CONTRACTOR SHOULD VERIFY THAT PONDING OF WATER WILL NOT OCCUR IN THE TRAVEL LANES.

4:53:05 PM  
 \\TCPLV5021\c\_pld\2a.dgn  
 \$\$\$USERNAME\$\$\$

**HNTB** HNTB NORTH CAROLINA, P.C.  
 343 E. Six Forks Road, Suite 200  
 Raleigh, North Carolina 27609  
 NC License No: C-1554

APPROVED: *Helen Shyne*  
 DATE: 9/9/2021

SEAL

DOCUMENT NOT CONSIDERED FINAL  
 UNLESS ALL SIGNATURES COMPLETED

DIVISION OF HIGHWAYS  
 STATE OF NORTH CAROLINA  
 DEPARTMENT OF TRANSPORTATION  
 WORK ZONE TRAFFIC CONTROL

TRANSPORTATION  
 MANAGEMENT PLAN

PHASE IA  
 DETAIL

REMOVE CONFLICTING PAVEMENT MARKING.

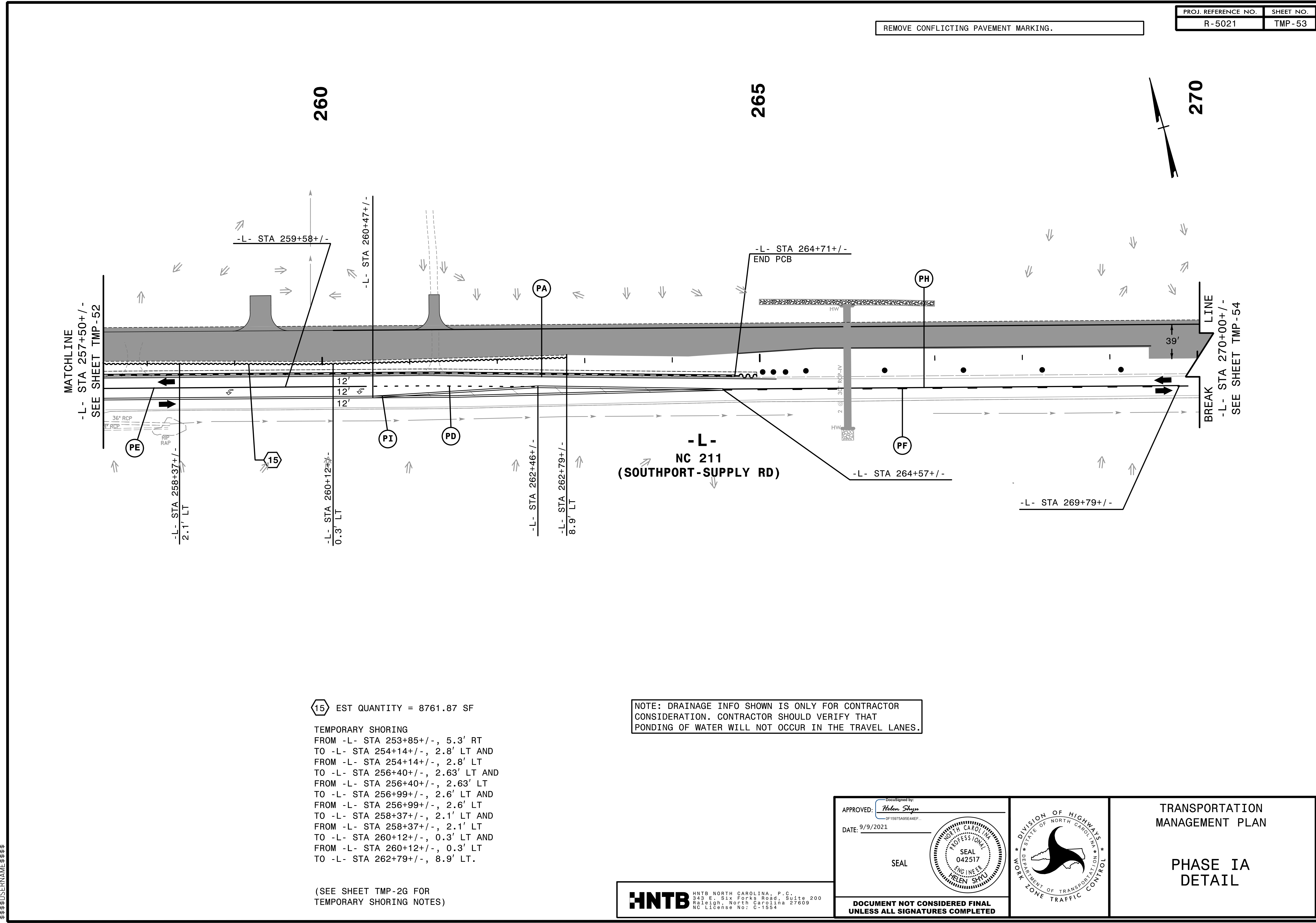

15 EST QUANTITY = 8761.87 SF

TEMPORARY SHORING  
 FROM -L- STA 253+85+/-, 5.3' RT  
 TO -L- STA 254+14+/-, 2.8' LT AND  
 FROM -L- STA 254+14+/-, 2.8' LT  
 TO -L- STA 256+40+/-, 2.63' LT AND  
 FROM -L- STA 256+40+/-, 2.63' LT  
 TO -L- STA 256+99+/-, 2.6' LT AND  
 FROM -L- STA 256+99+/-, 2.6' LT  
 TO -L- STA 258+37+/-, 2.1' LT AND  
 FROM -L- STA 258+37+/-, 2.1' LT  
 TO -L- STA 260+12+/-, 0.3' LT AND  
 FROM -L- STA 260+12+/-, 0.3' LT  
 TO -L- STA 262+79+/-, 8.9' LT.

(SEE SHEET TMP-2G FOR TEMPORARY SHORING NOTES)

NOTE: DRAINAGE INFO SHOWN IS ONLY FOR CONTRACTOR CONSIDERATION. CONTRACTOR SHOULD VERIFY THAT PONDING OF WATER WILL NOT OCCUR IN THE TRAVEL LANES.

4:53:08 PM  
 ...\\TCPL\5021\_fc\_pid\3adgn  
 \$\$\$USERNAME\$\$\$

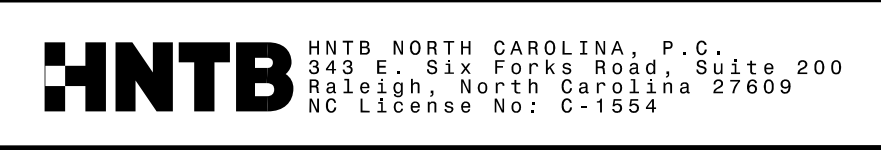

APPROVED: *Helen Shyu*  
 DATE: 9/9/2021

SEAL

DOCUMENT NOT CONSIDERED FINAL UNLESS ALL SIGNATURES COMPLETED

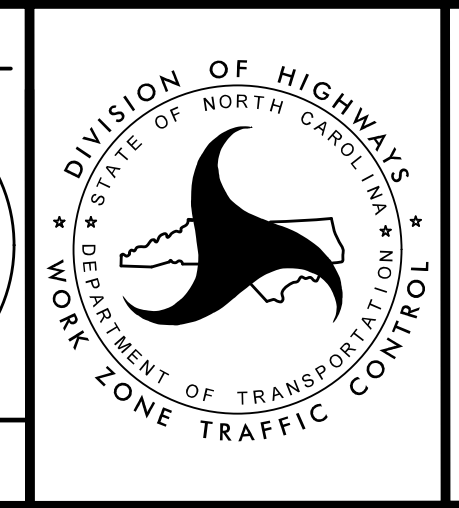

TRANSPORTATION MANAGEMENT PLAN

PHASE IA DETAIL

PROJ. REFERENCE NO.	SHEET NO.
R-5021	TMP-54

REMOVE CONFLICTING PAVEMENT MARKING.

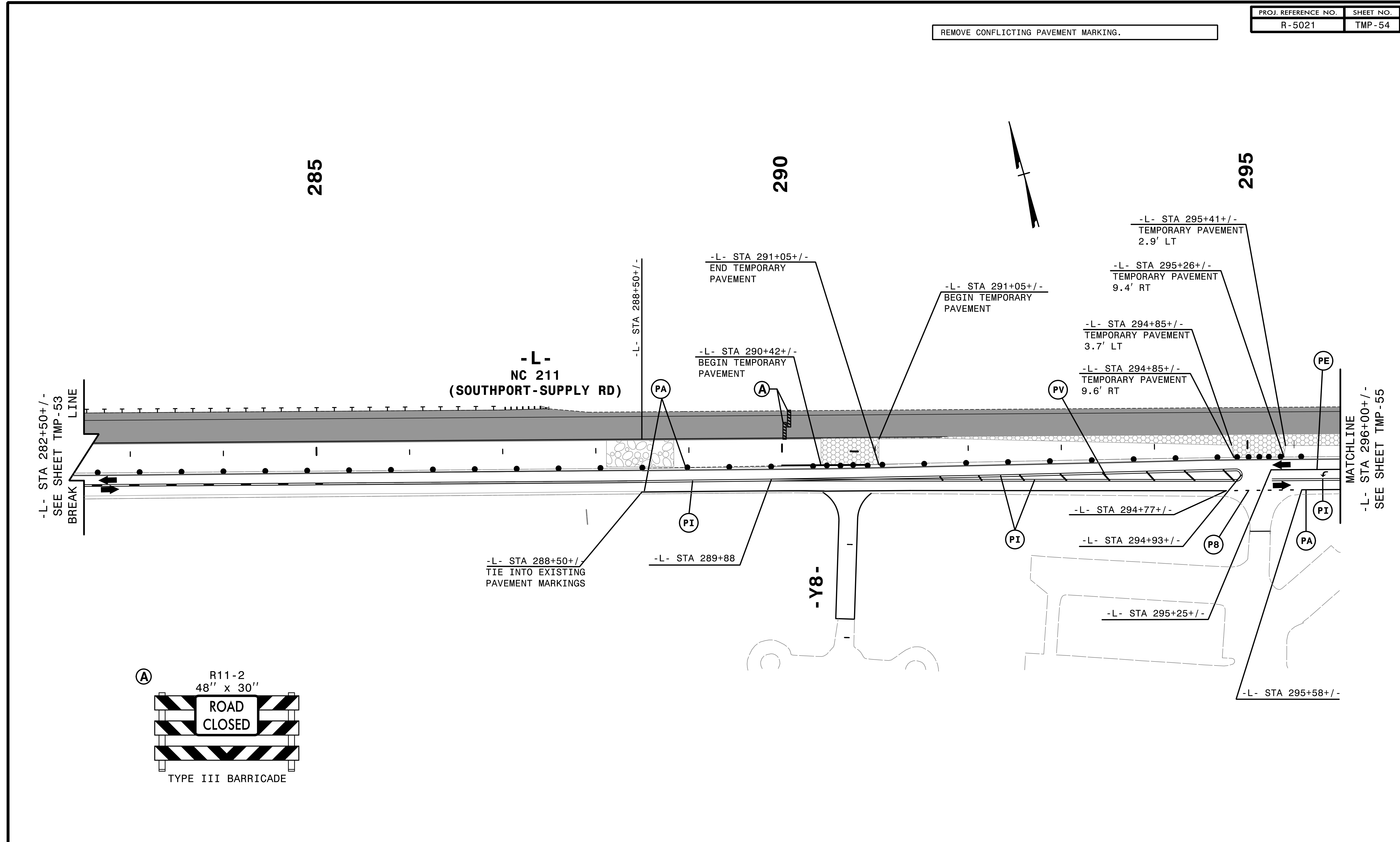

-L- STA 282+50+/-  
SEE SHEET TMP-53  
BREAK  
LINE

-L-  
NC 211  
(SOUTHPORT-SUPPLY RD)

-L- STA 288+50+/-  
TIE INTO EXISTING  
PAVEMENT MARKINGS

-L- STA 289+88

-L- STA 291+05+/-  
END TEMPORARY  
PAVEMENT

-L- STA 290+42+/-  
BEGIN TEMPORARY  
PAVEMENT

-L- STA 291+05+/-  
BEGIN TEMPORARY  
PAVEMENT

-L- STA 295+41+/-  
TEMPORARY PAVEMENT  
2.9' LT

-L- STA 295+26+/-  
TEMPORARY PAVEMENT  
9.4' RT

-L- STA 294+85+/-  
TEMPORARY PAVEMENT  
3.7' LT

-L- STA 294+85+/-  
TEMPORARY PAVEMENT  
9.6' RT

-L- STA 294+77+/-

-L- STA 294+93+/-

-L- STA 295+25+/-

-L- STA 295+58+/-

MATCHLINE  
-L- STA 296+00+/-  
SEE SHEET TMP-55

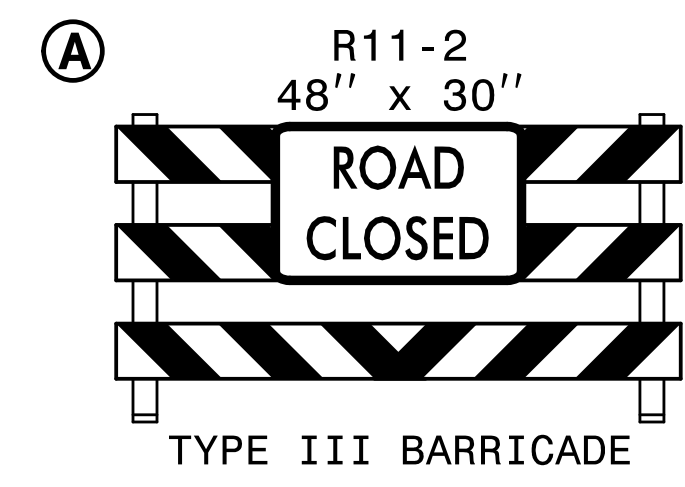

2/6/2019  
HNTB  
C:\CPV\5021\Tc\_pid15a.dgn

**HNTB** HNTB NORTH CAROLINA, P.C.  
343 E. Six Forks Road, Suite 200  
Raleigh, North Carolina 27609  
NC License No: C-1554

APPROVED: *Helen Skyy*  
DATE: 2/6/2019  
SEAL  
DOCUMENT NOT CONSIDERED FINAL  
UNLESS ALL SIGNATURES COMPLETED

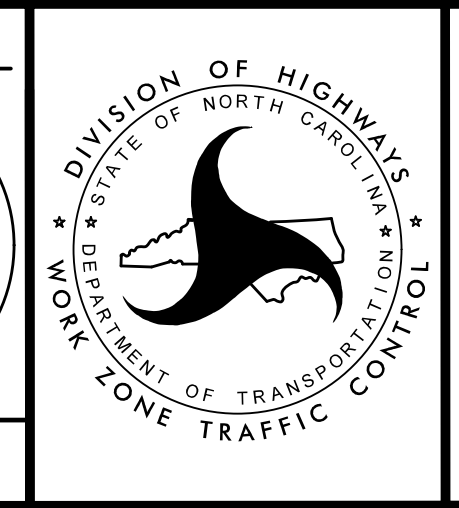

TRANSPORTATION  
MANAGEMENT PLAN  
  
PHASE IA  
DETAIL

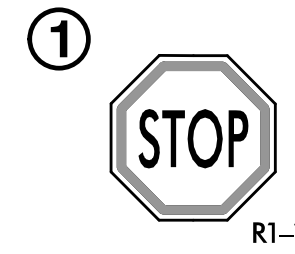

REMOVE CONFLICTING PAVEMENT MARKING.

INSTALL SIGNS AS REQUIRED PER RSD 1101.03 (SHEET 3 OF 9).

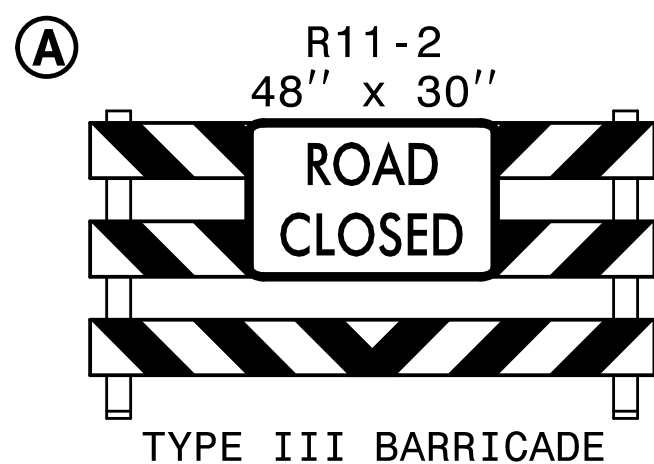
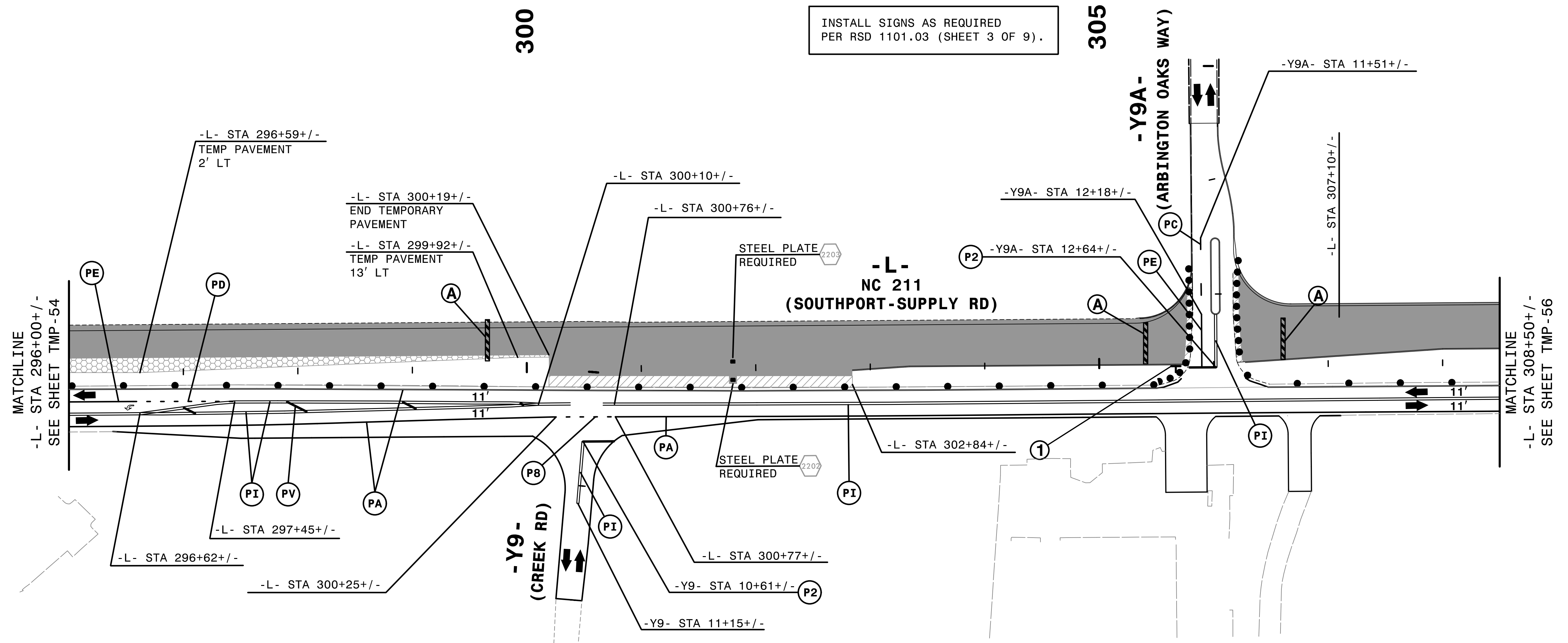

2:51:59 PM  
 C:\Users\5021\Documents\2021\10\28\1021\1021.dgn  
 \$\$\$USERNAME\$\$\$

**HNTB** HNTB NORTH CAROLINA, P.C.  
 343 E. Six Forks Road, Suite 200  
 Raleigh, North Carolina 27609  
 NC License No: C-1554

APPROVED: *Helen Shyu*  
 DATE: 10/28/2021  
 SEAL  
 DOCUMENT NOT CONSIDERED FINAL UNLESS ALL SIGNATURES COMPLETED

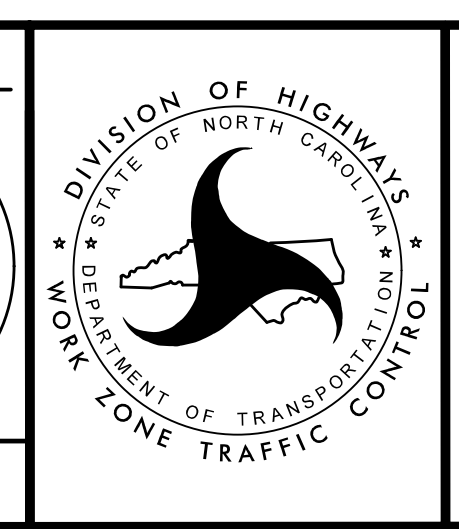

TRANSPORTATION MANAGEMENT PLAN  
 PHASE IA DETAIL  
 DIVISION OF HIGHWAYS  
 STATE OF NORTH CAROLINA  
 DEPARTMENT OF TRANSPORTATION  
 WORK ZONE TRAFFIC CONTROL

REMOVE CONFLICTING PAVEMENT MARKING.

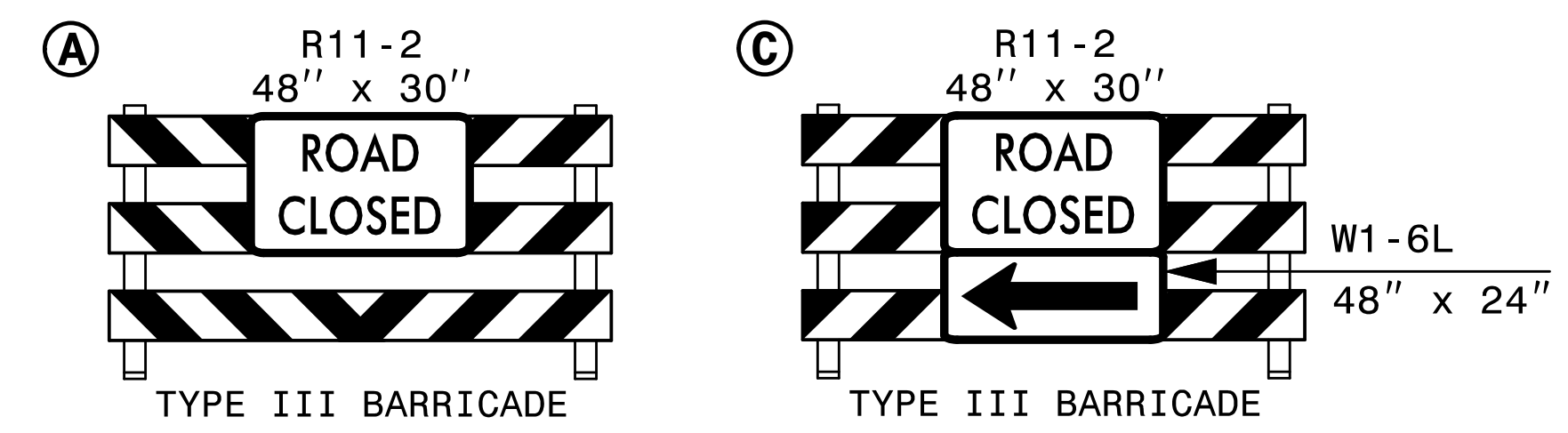

**(16)** EST QUANTITY = 766.5 SF  
 TEMPORARY SHORING  
 FROM -L- STA 316+15+/-, 8' LT  
 TO -L- STA 317+21+/-, 7.18' LT  
 (SEE SHEET TMP-2G FOR TEMPORARY SHORING NOTES)

**(17)** EST QUANTITY = 1106 SF  
 TEMPORARY SHORING  
 FROM -L- STA 316+02+/-, 9' LT  
 TO -L- STA 317+23+/-, 9' LT  
 (SEE SHEET TMP-2G FOR TEMPORARY SHORING NOTES)

INSTALL SIGNS AS REQUIRED PER RSD 1101.03 (SHEET 3 OF 9.)

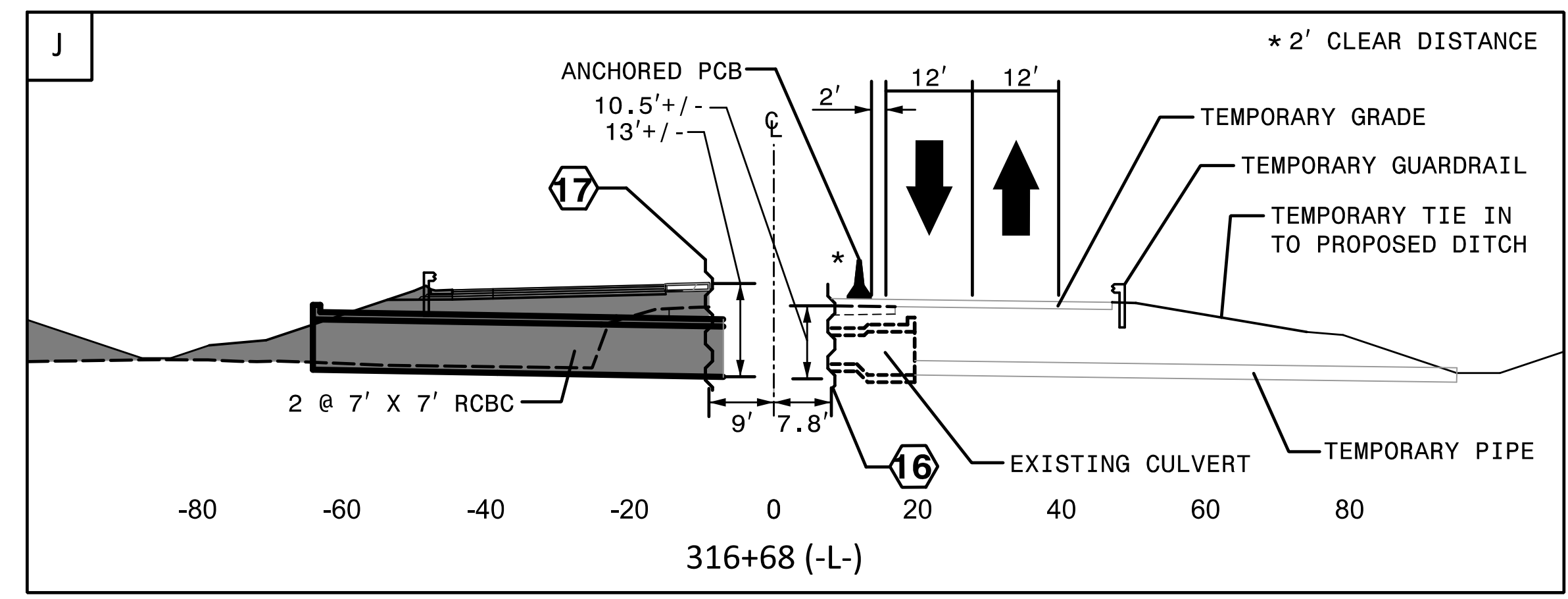
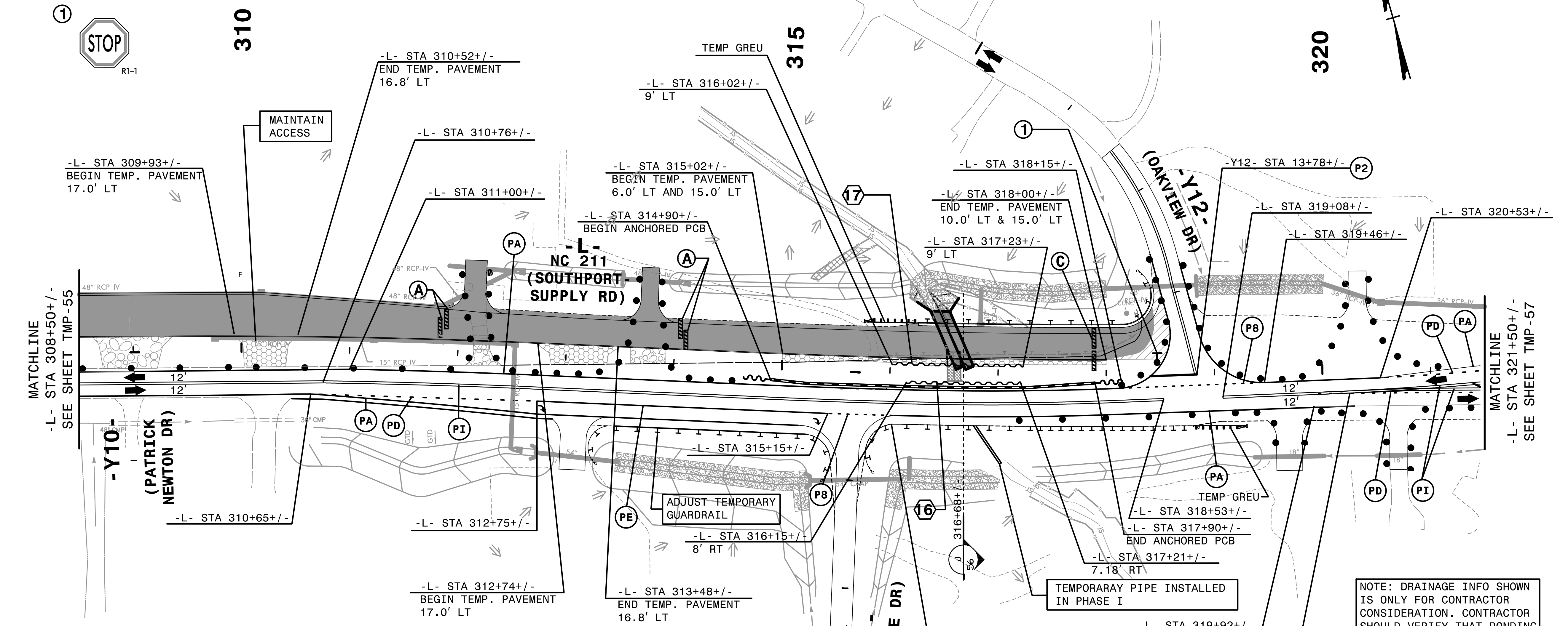

NOTE: DRAINAGE INFO SHOWN IS ONLY FOR CONTRACTOR CONSIDERATION. CONTRACTOR SHOULD VERIFY THAT PONDING OF WATER WILL NOT OCCUR IN THE TRAVEL LANES.

SEE EC-23A/CONST.23 FOR CULVERT PHASING

10/09/2021 10:09:29 AM  
\\TCPL-5021-10-pld\adgn  
\$\$\$\$\$USERNAME\$\$\$\$\$

**HNTB** HNTB NORTH CAROLINA, P.C.  
 343 E. Six Forks Road, Suite 200  
 Raleigh, North Carolina 27609  
 NC License No: C-1554

APPROVED: *Helen Shyu*  
 DATE: 10/28/2021  
 SEAL  
 DOCUMENT NOT CONSIDERED FINAL  
 UNLESS ALL SIGNATURES COMPLETED

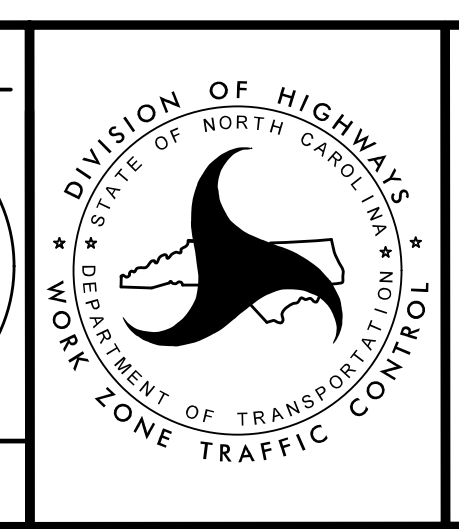

TRANSPORTATION  
 MANAGEMENT PLAN  
 PHASE IA  
 DETAIL

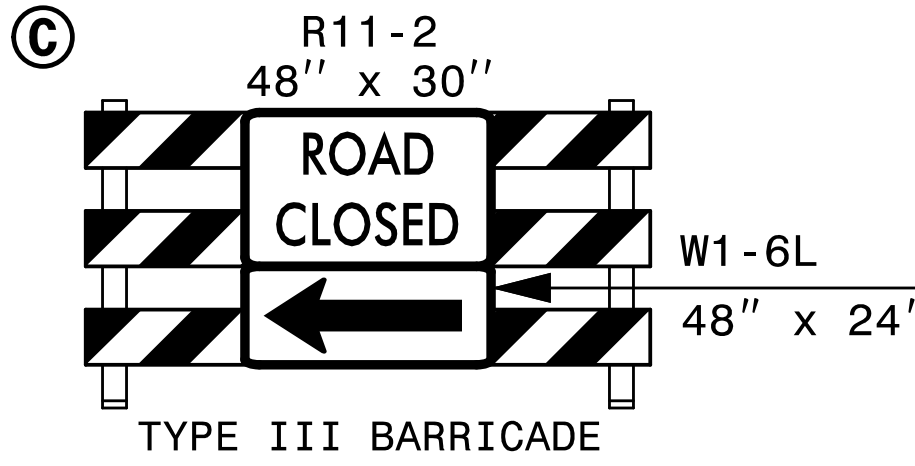
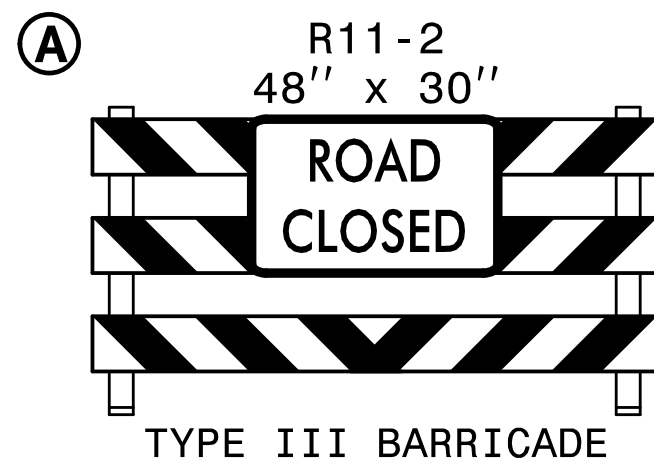

INSTALL SIGNS AS REQUIRED  
PER RSD 1101.03 (SHEET 3 OF 9.)

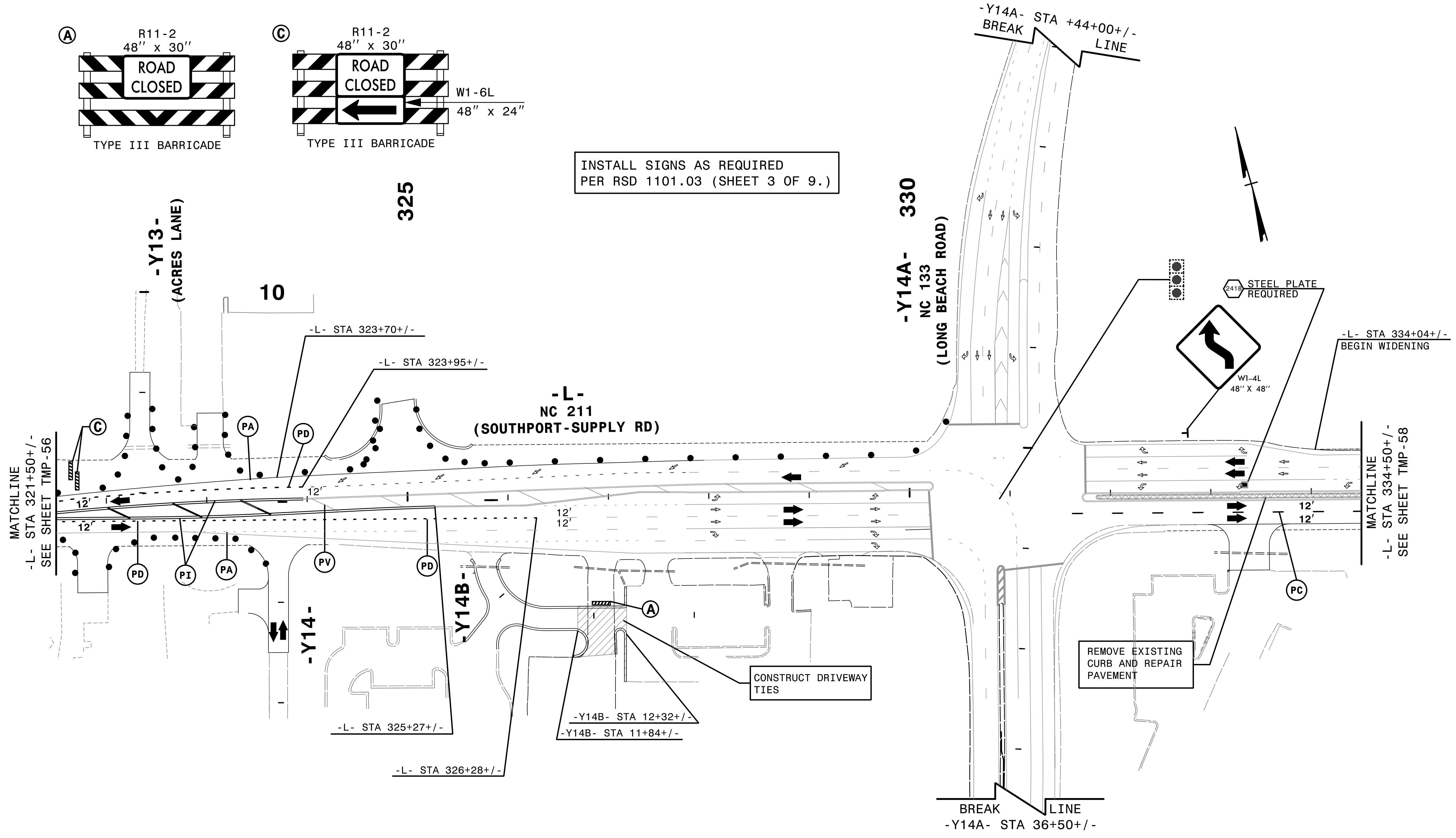

MATCHLINE  
-L- STA 321+50+/-  
SEE SHEET TMP-56

MATCHLINE  
-L- STA 334+50+/-  
SEE SHEET TMP-58

REMOVE CONFLICTING PAVEMENT MARKING.

4:53:25 PM  
...\\TC\...5021...\_fc\_p1d18a.dgn  
\$\$\$USERNAME\$\$\$

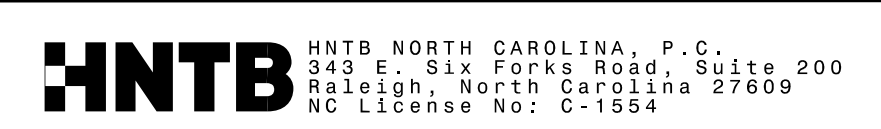

APPROVED: *Helen Shyu*  
DATE: 9/9/2021

SEAL

DOCUMENT NOT CONSIDERED FINAL  
UNLESS ALL SIGNATURES COMPLETED

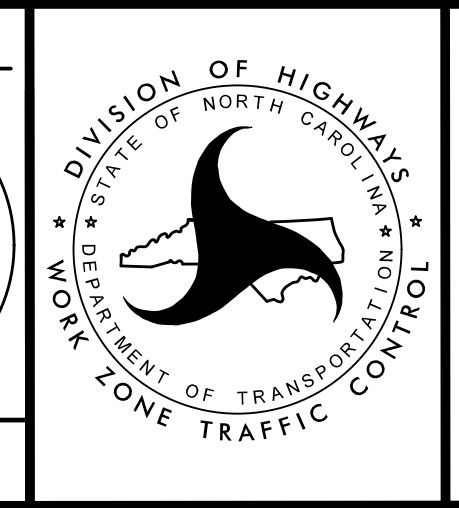

TRANSPORTATION  
MANAGEMENT PLAN

PHASE IA  
DETAIL



REMOVE CONFLICTING PAVEMENT MARKING.

PROJ. REFERENCE NO.	SHEET NO.
R-5021	TMP-58

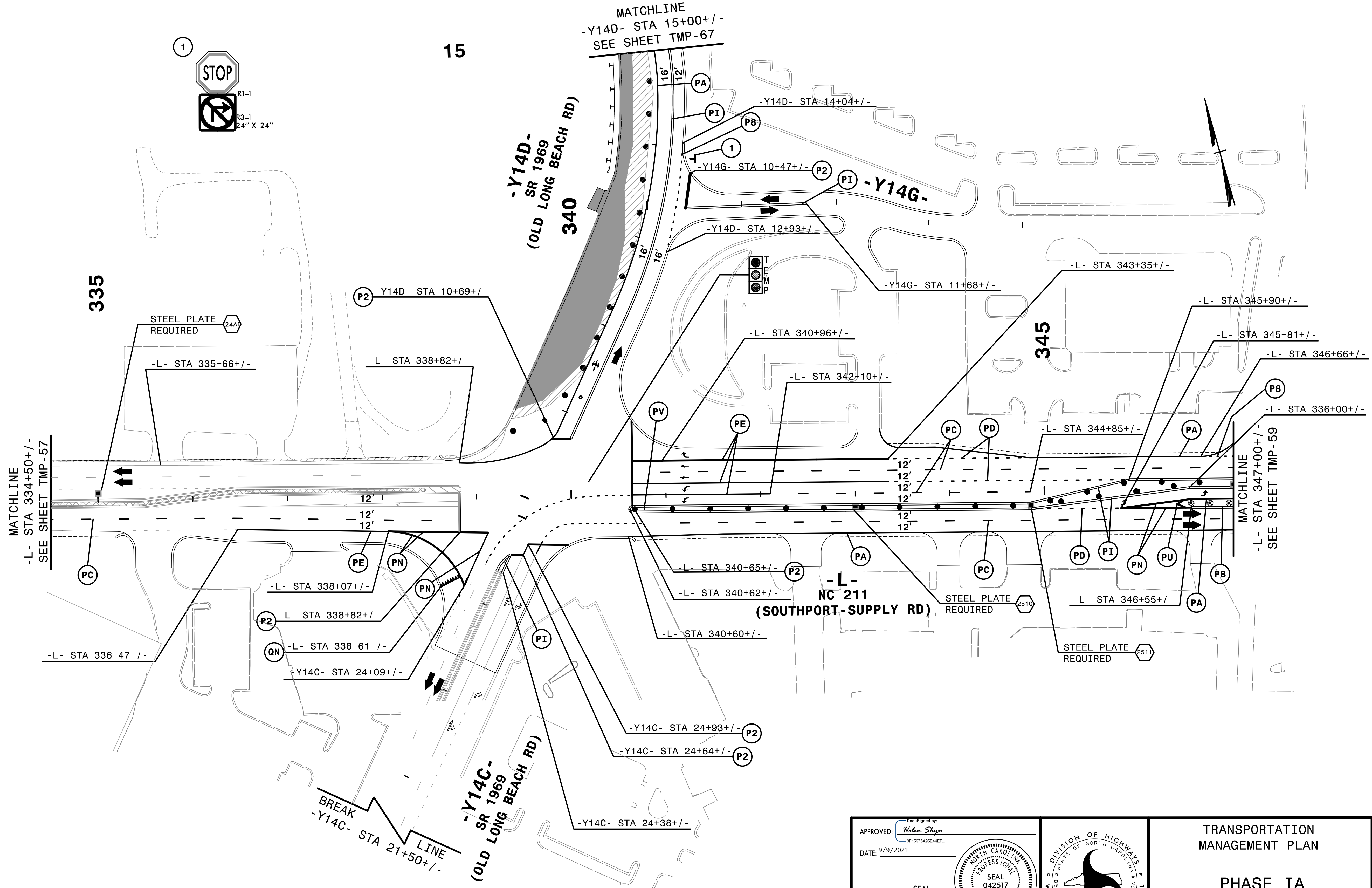

4:31:46 PM  
\\TCF\15021\_Tc\_pid19a.dgn  
\$\$\$\$\$USERNAME\$\$\$\$\$

**HNTB** HNTB NORTH CAROLINA, P.C.  
343 E. Six Forks Road, Suite 200  
Raleigh, North Carolina 27609  
NC License No: C-1554

APPROVED: *Helen Shyu*  
DATE: 9/9/2021  
SEAL  
DOCUMENT NOT CONSIDERED FINAL  
UNLESS ALL SIGNATURES COMPLETED

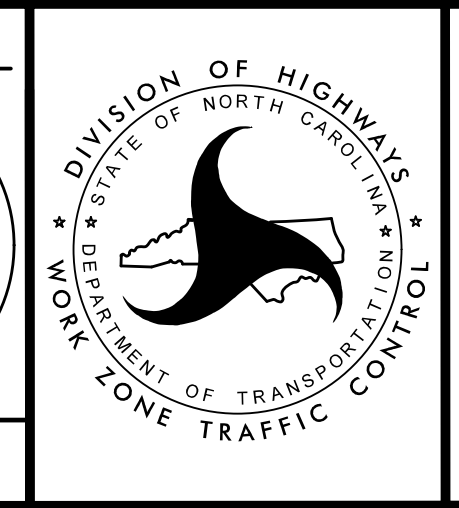

DIVISION OF HIGHWAYS  
STATE OF NORTH CAROLINA  
DEPARTMENT OF TRANSPORTATION  
WORK ZONE TRAFFIC CONTROL

TRANSPORTATION  
MANAGEMENT PLAN

PHASE IA  
DETAIL

REMOVE CONFLICTING PAVEMENT MARKING.

PROJ. REFERENCE NO.	SHEET NO.
R-5021	TMP-59

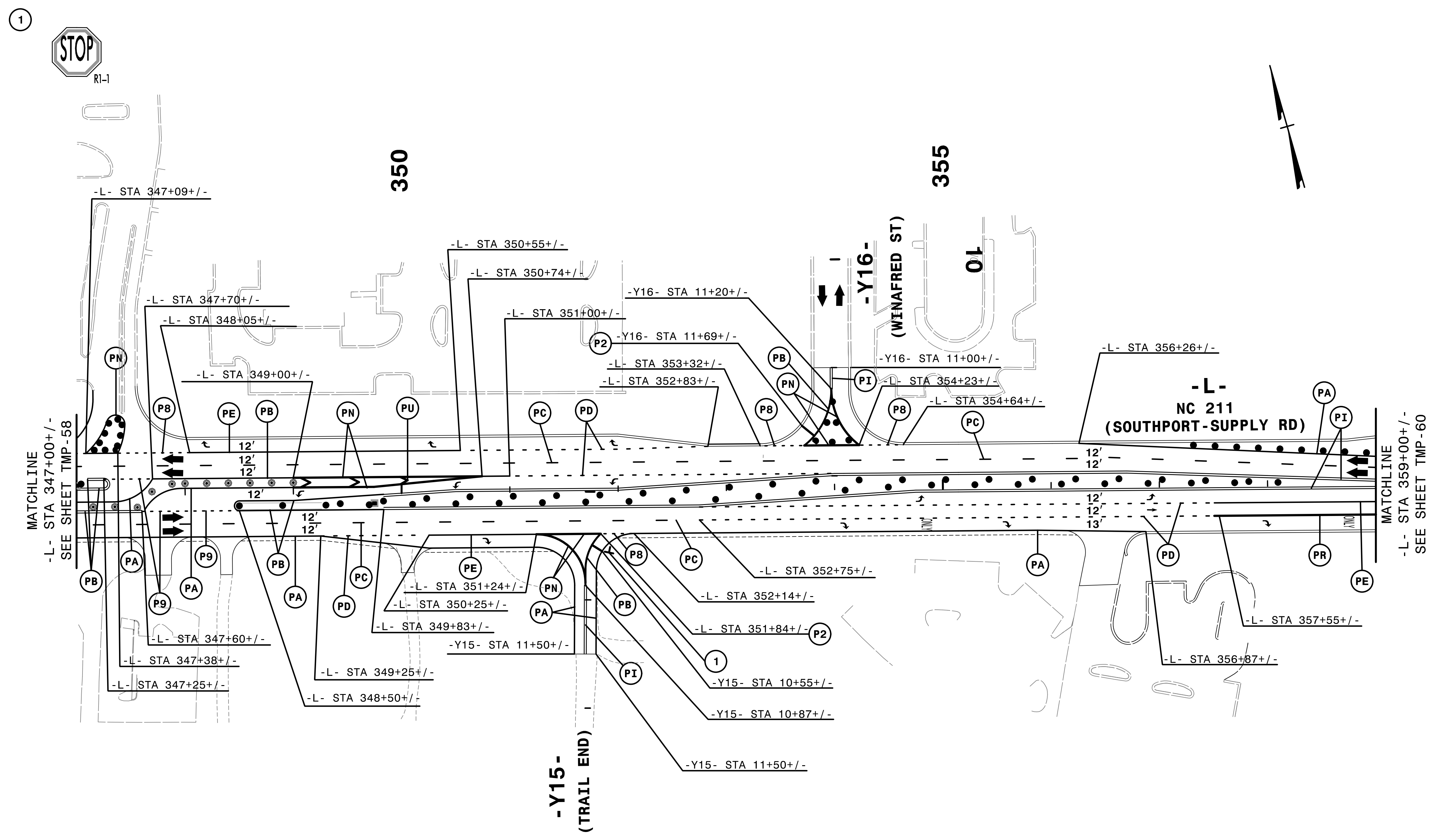

4:53:30 PM  
...\\TC\...5021...\_p\d20a.dgn  
\$\$\$USERNAME\$\$\$

**HNTB** HNTB NORTH CAROLINA, P.C.  
343 E. Six Forks Road, Suite 200  
Raleigh, North Carolina 27609  
NC License No: C-1554

APPROVED: *Helen Shyu*  
DATE: 9/9/2021  
SEAL  
DOCUMENT NOT CONSIDERED FINAL  
UNLESS ALL SIGNATURES COMPLETED

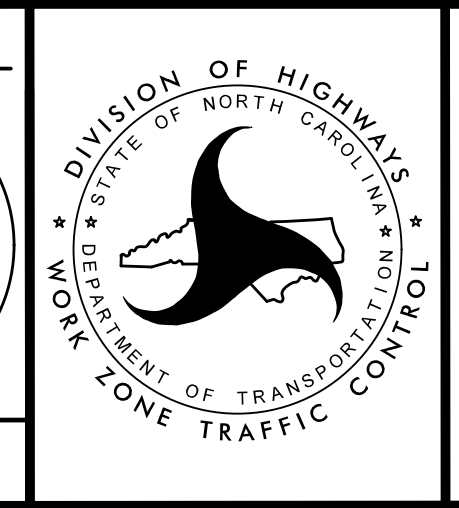
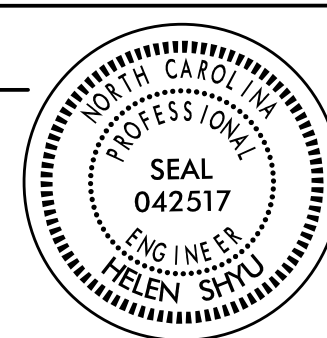

TRANSPORTATION  
MANAGEMENT PLAN  
  
PHASE IA  
DETAIL

REMOVE CONFLICTING PAVEMENT MARKING.

PROJ. REFERENCE NO.	SHEET NO.
R-5021	TMP-60

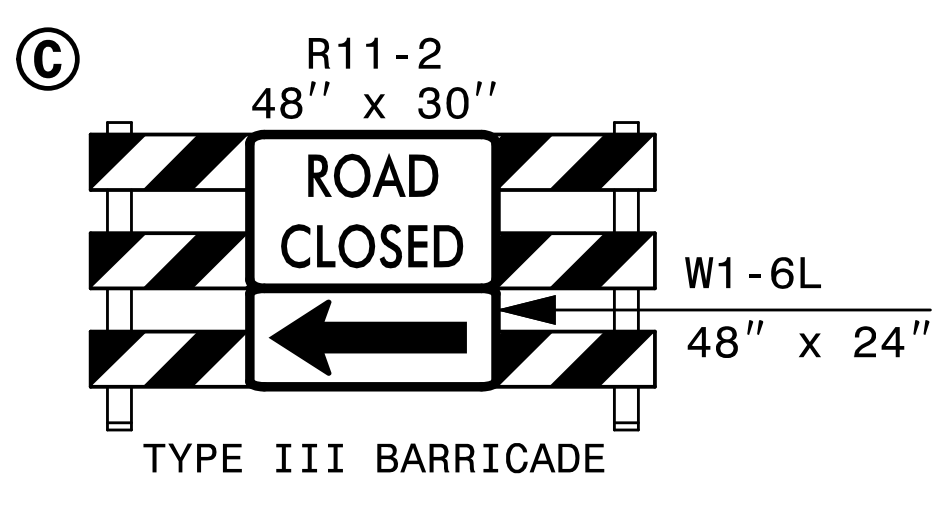
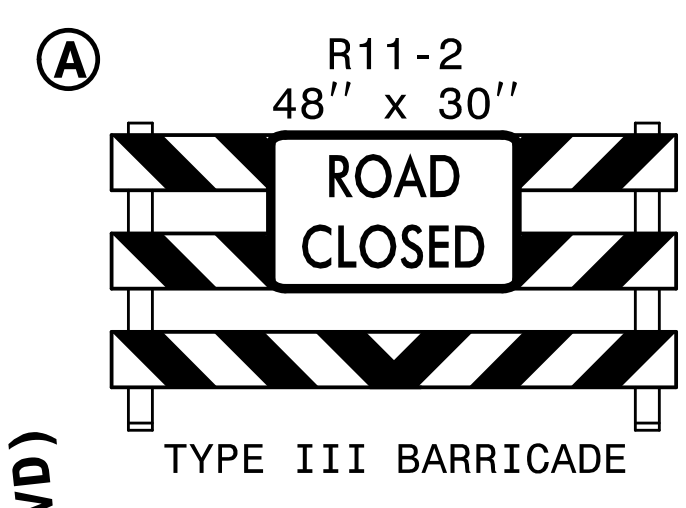

**18** EST QUANTITY = 1755 SF  
 TEMPORARY SHORING  
 FROM -L- STA 366+60+/-, 8.26' LT  
 TO -L- STA 367+50+/-, 0' LT AND  
 FROM -L- STA 367+50+/-, 0' LT  
 TO -L- STA 368+91+/-, 0' LT  
 (SEE SHEET TMP-2G FOR TEMPORARY SHORING NOTES)

**19** EST QUANTITY = 1051.2 SF  
 TEMPORARY SHORING  
 FROM -L- STA 370+10+/-, 0' LT  
 TO -LREV- STA 371+50+/-, 0.6' LT  
 (SEE SHEET TMP-2G FOR TEMPORARY SHORING NOTES)

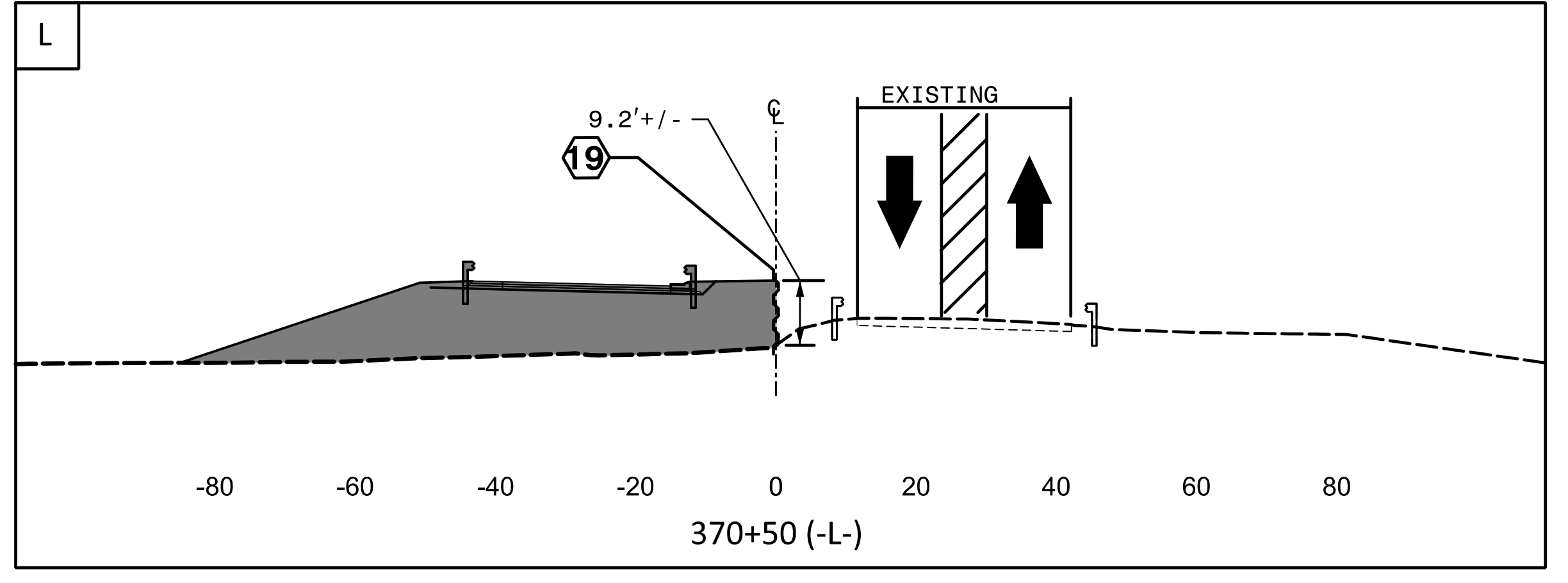
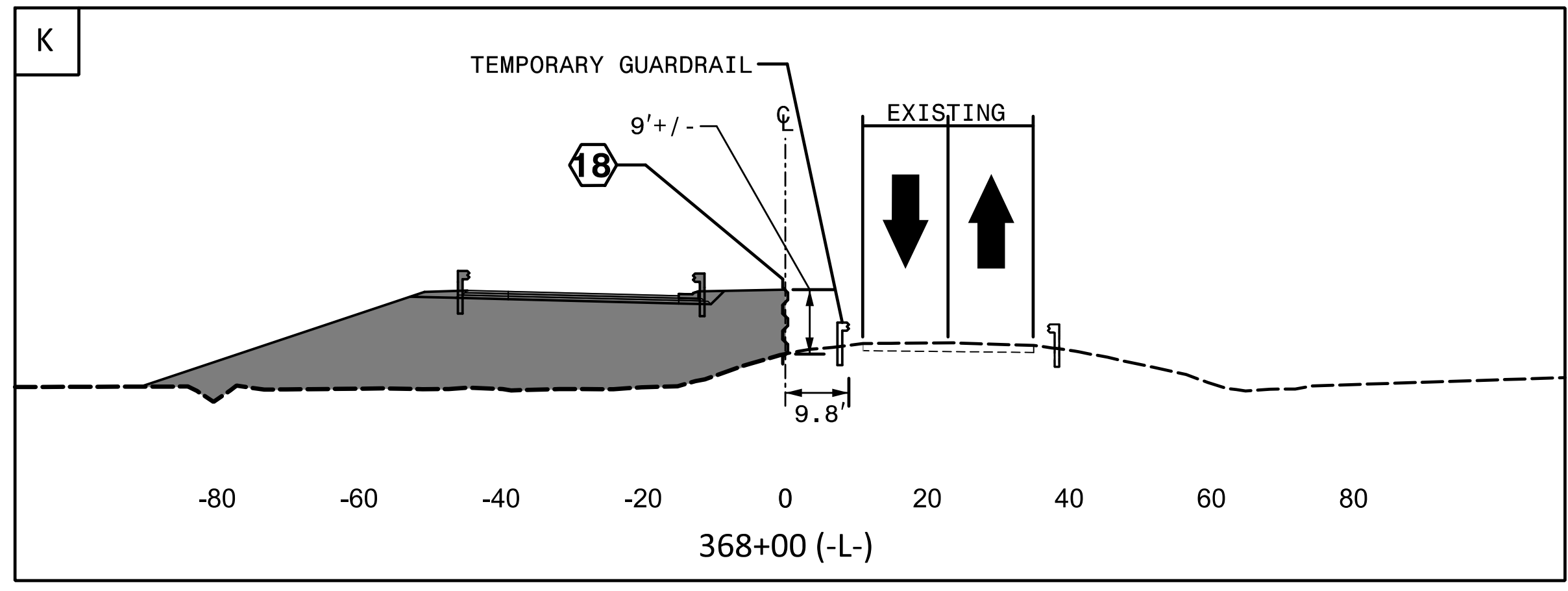
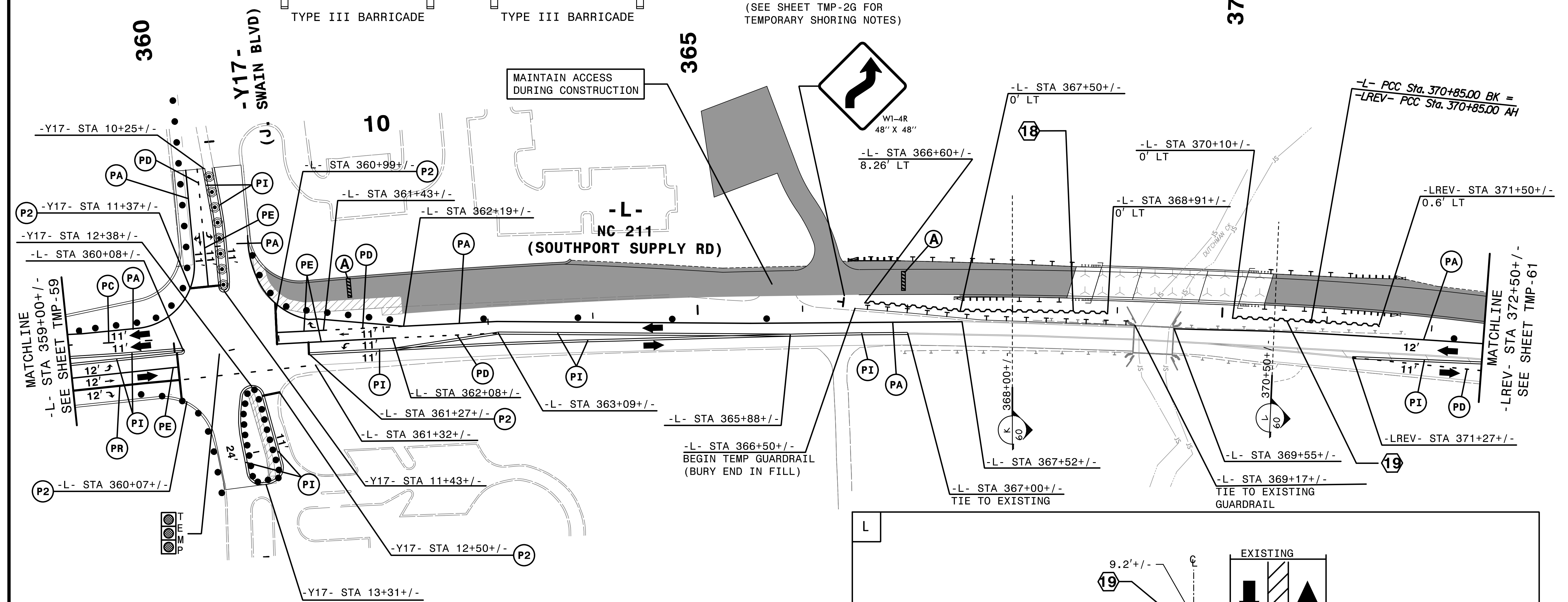

4:53:36 PM  
...TCPL...502...TC...pld2la.dgn  
...\$\$\$USERNAME\$\$\$

**HNTB** HNTB NORTH CAROLINA, P.C.  
343 E. Six Forks Road, Suite 200  
Raleigh, North Carolina 27609  
NC License No: C-1554

APPROVED: *Helen Shyu*  
 DATE: 9/9/2021  
 SEAL  
 DOCUMENT NOT CONSIDERED FINAL  
 UNLESS ALL SIGNATURES COMPLETED

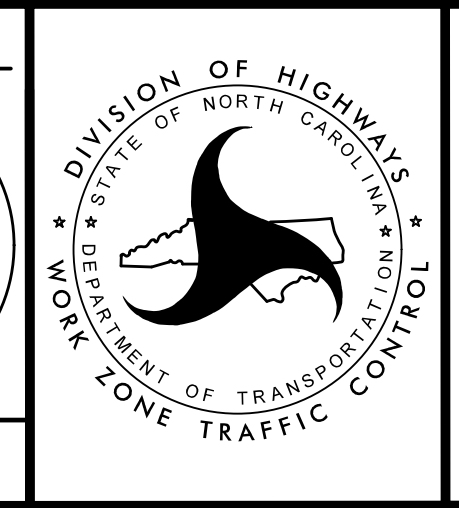

TRANSPORTATION  
 MANAGEMENT PLAN  
 PHASE IA  
 DETAIL  
 DIVISION OF HIGHWAYS  
 STATE OF NORTH CAROLINA  
 DEPARTMENT OF TRANSPORTATION  
 WORK ZONE TRAFFIC CONTROL

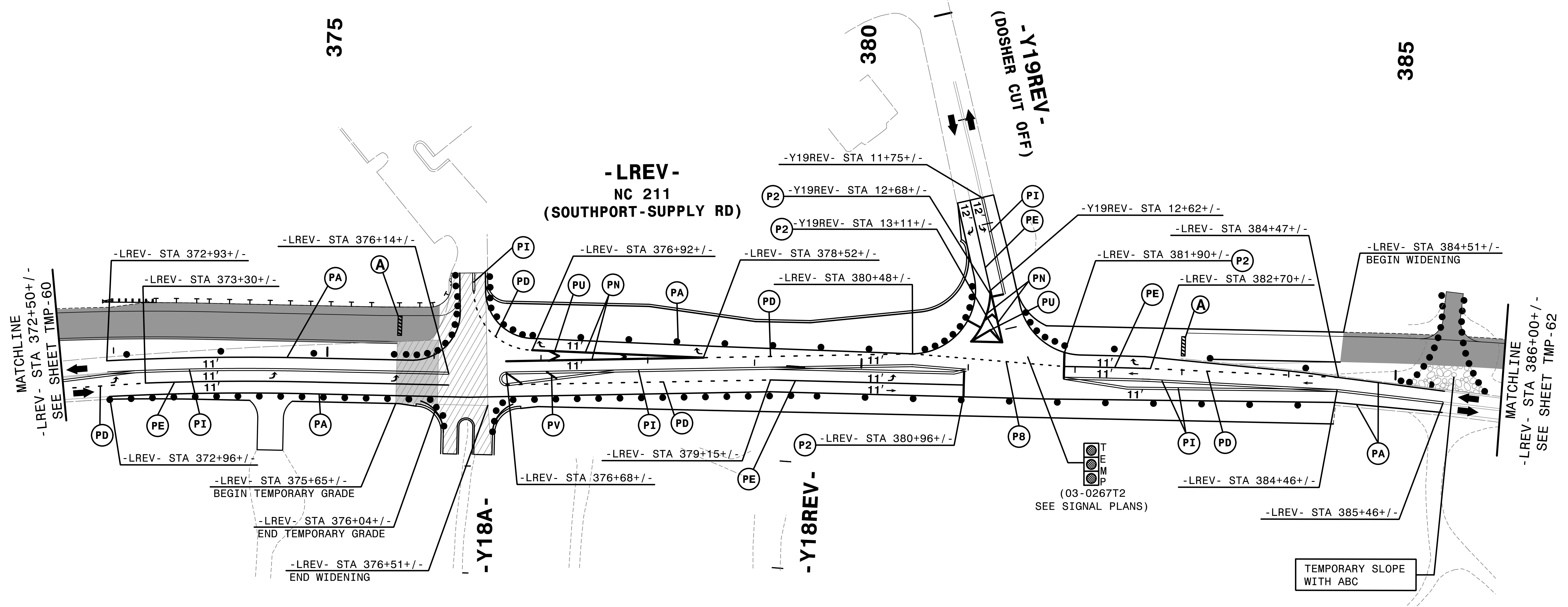
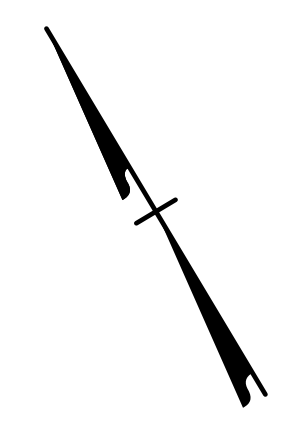
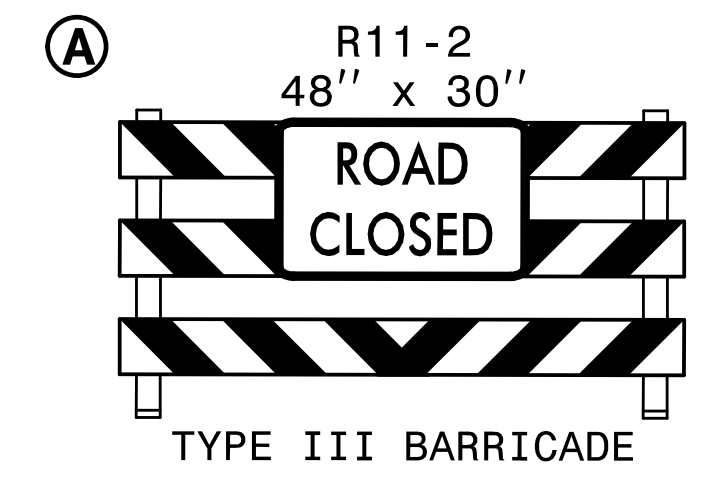

4:53:40 PM  
 ...\\TCP\5021\c.pld22a.dgn  
 \$\$\$USERNAME\$\$\$

REMOVE CONFLICTING PAVEMENT MARKING.

**HNTB** HNTB NORTH CAROLINA, P.C.  
 343 E. SIX FORKS ROAD, SUITE 200  
 RALEIGH, NORTH CAROLINA 27609  
 NC LICENSE NO: C-1554

APPROVED: *Helen Shyne*  
 DATE: 9/9/2021

SEAL

DOCUMENT NOT CONSIDERED FINAL  
 UNLESS ALL SIGNATURES COMPLETED

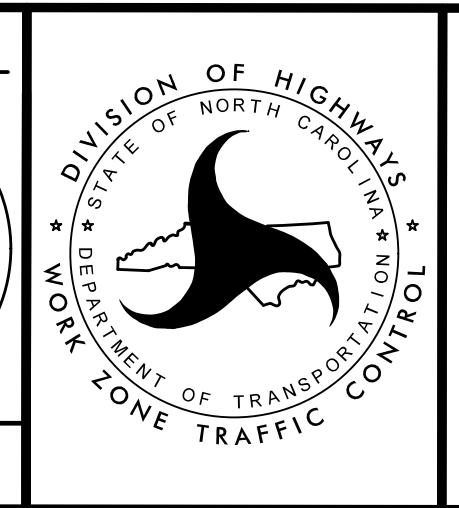

TRANSPORTATION  
 MANAGEMENT PLAN

PHASE IA  
 DETAIL

PROJ. REFERENCE NO.	SHEET NO.
R-5021	TMP-62

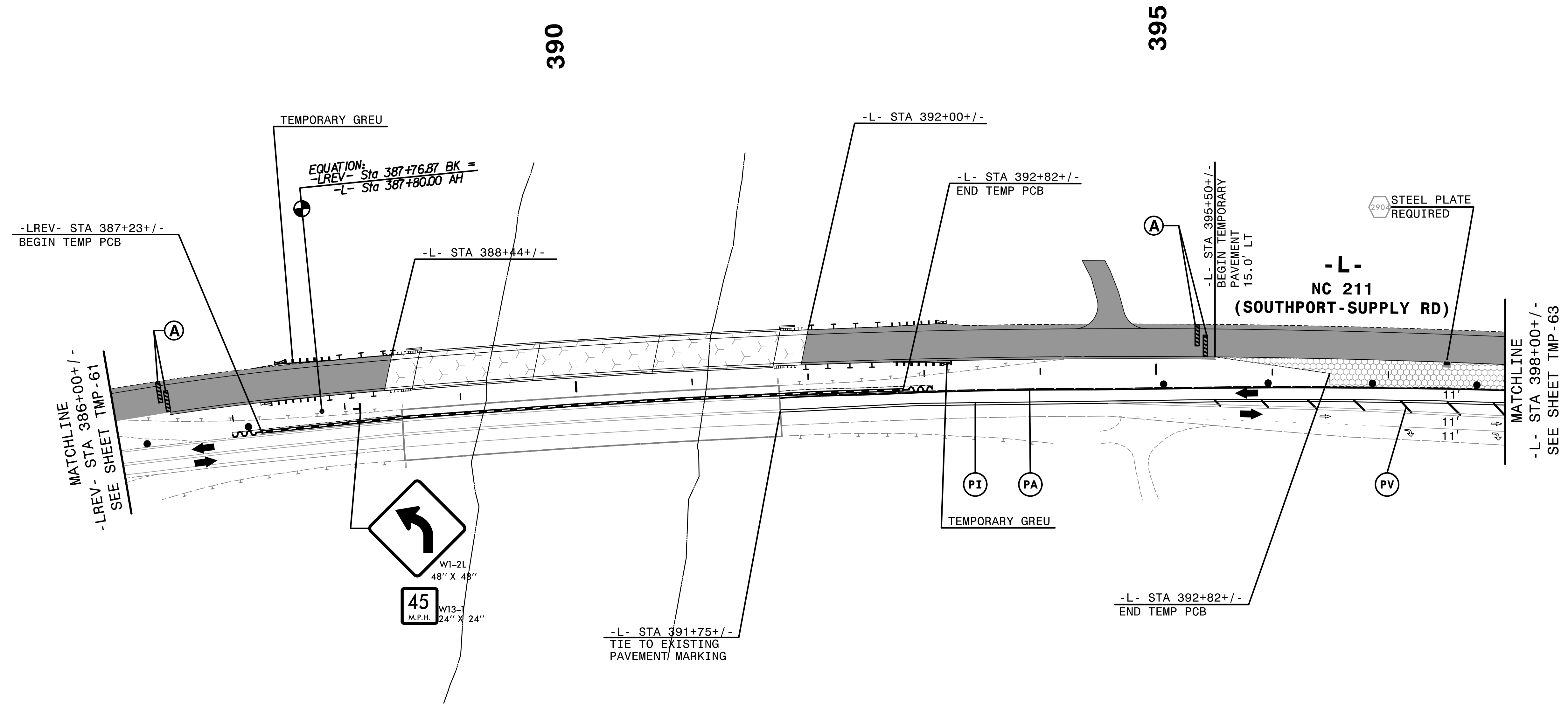
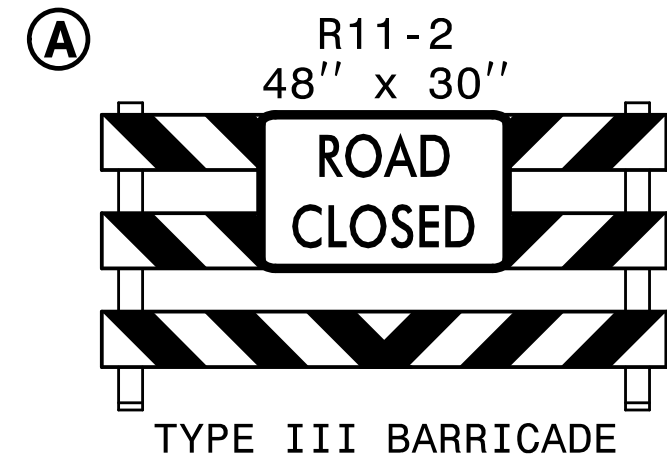

4:53:43 PM  
 \\TCPL15021\c\_pld23a.dgn  
 \$\$\$USERNAME\$\$\$

REMOVE CONFLICTING PAVEMENT MARKING.

**HNTB** HNTB NORTH CAROLINA, P.C.  
 343 E. Six Forks Road, Suite 200  
 Raleigh, North Carolina 27609  
 NC License No: C-1554

APPROVED: *Helen Shyu*  
 DATE: 9/9/2021  
 SEAL  
 DOCUMENT NOT CONSIDERED FINAL  
 UNLESS ALL SIGNATURES COMPLETED

SEAL  
 042517  
 HELLEN SHYU  
 ENGINEER  
 STATE OF NORTH CAROLINA

TRANSPORTATION  
 MANAGEMENT PLAN  
 PHASE IA  
 DETAIL

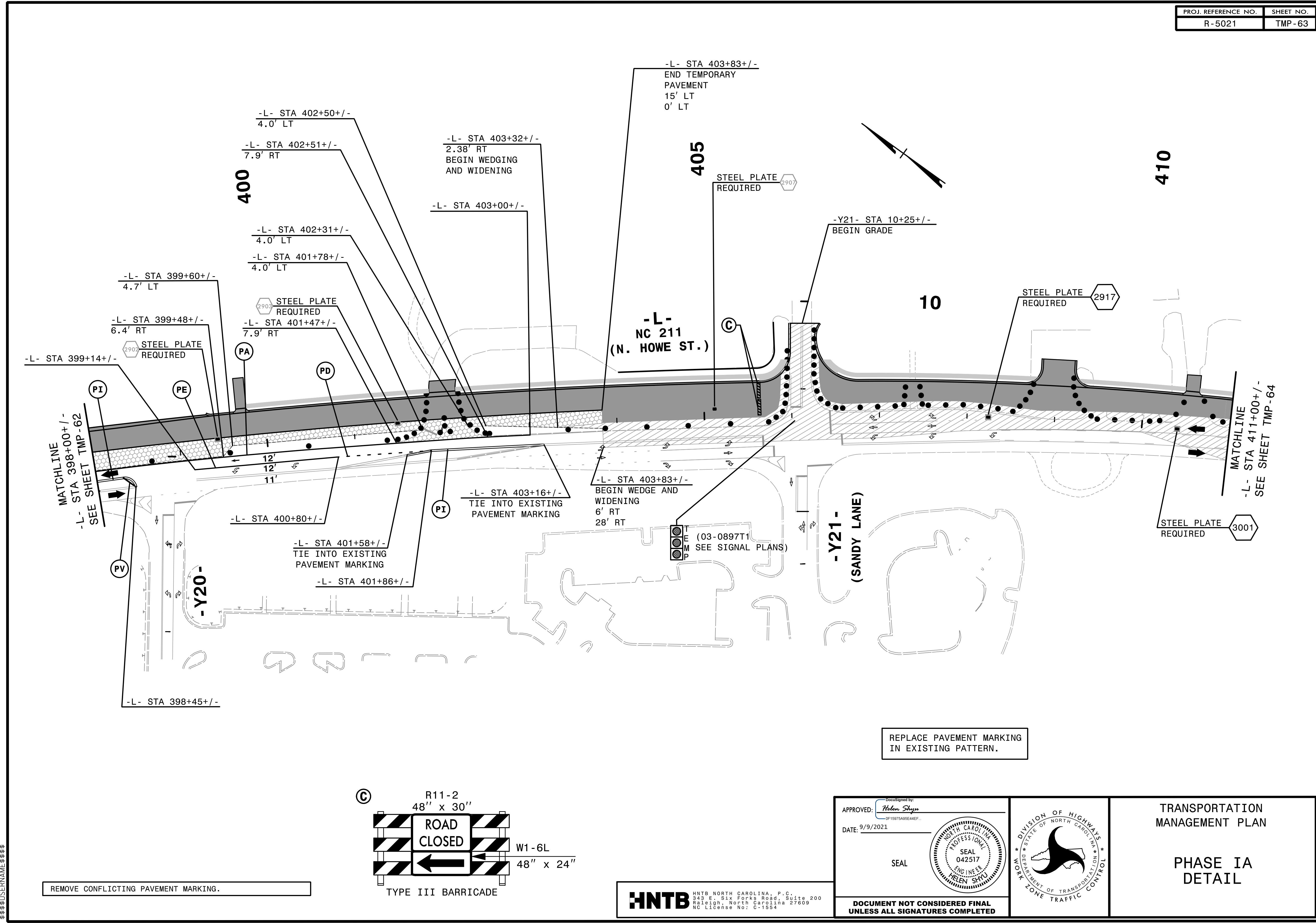

4:53:53 PM  
\\TCPL\F5021\_Tc\_Pld24a.dgn  
\$\$\$\$\$USERNAME\$\$\$\$\$

REMOVE CONFLICTING PAVEMENT MARKING.

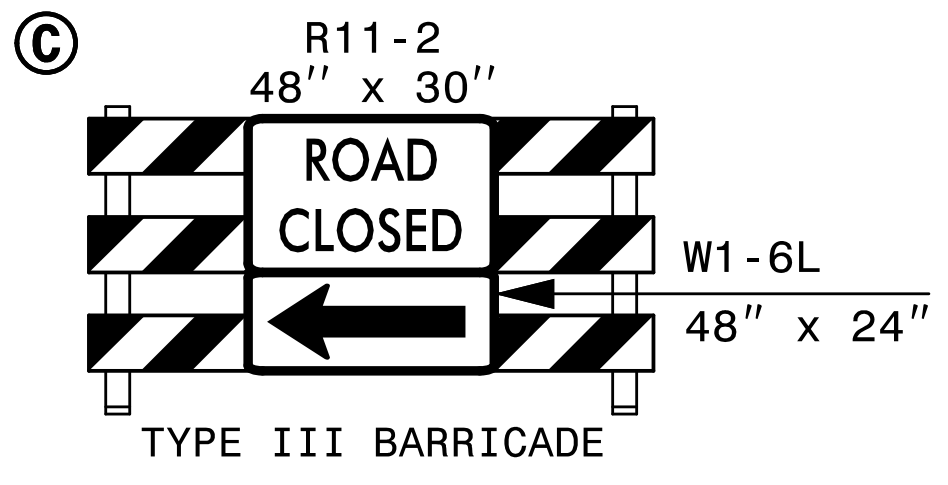

REPLACE PAVEMENT MARKING IN EXISTING PATTERN.

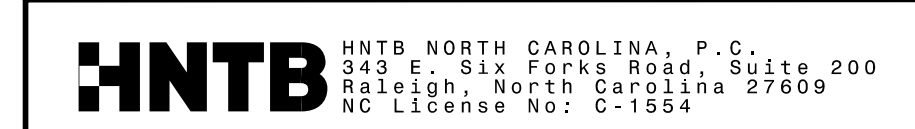

APPROVED: *Helen Shyne*  
DATE: 9/9/2021

SEAL

PROFESSIONAL ENGINEER  
HELEN SHYNE  
042517

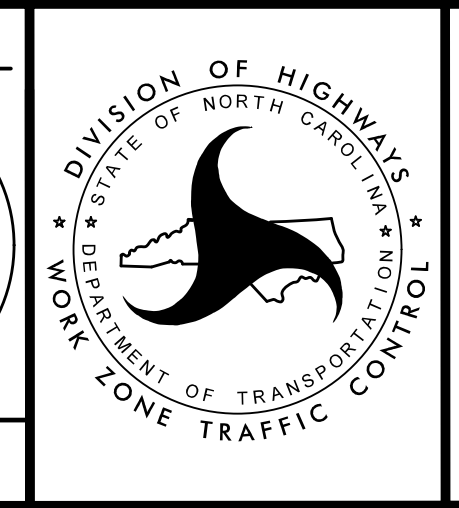

TRANSPORTATION MANAGEMENT PLAN

PHASE IA DETAIL

DOCUMENT NOT CONSIDERED FINAL UNLESS ALL SIGNATURES COMPLETED

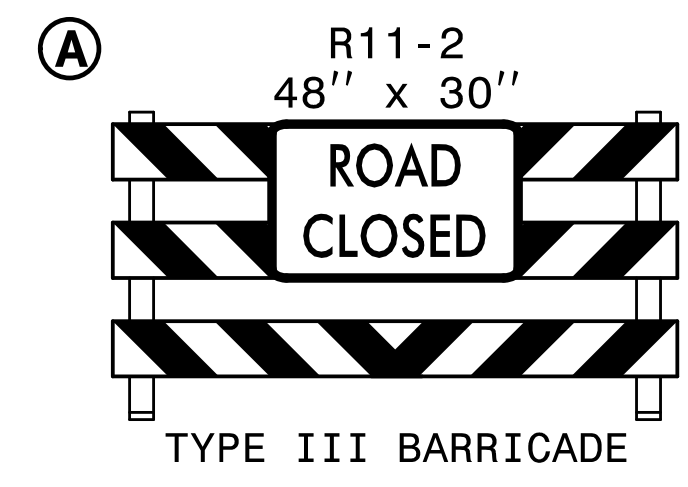

415

420

USING LANE CLOSURES, EXCAVATE SOIL AND CONSTRUCT PROPOSED PAVEMENT FROM -L- STA 411+50+/- TO 412+80+/- (LEFT).

-L-  
NC 211  
(N. HOWE ST)

MATCHLINE  
-L- STA 411+00+/-  
SEE SHEET TMP-63

MATCHLINE  
-L- STA 423+00+/-  
SEE SHEET TMP-65

3002 STEEL PLATE  
REQUIRED

3029 STEEL PLATE  
REQUIRED

3003 STEEL PLATE  
REQUIRED

3035 STEEL PLATE  
REQUIRED

3039 STEEL PLATE  
REQUIRED

STEEL PLATE  
REQUIRED 3004

WEDGE -L- CONSTRUCT TEMPORARY GRADE, TIE-IN TO EXISTING DRIVEWAYS AND TEMPORARY SLOPE TO EXISTING DITCHES.

REPLACE PAVEMENT MARKING IN EXISTING PATTERN.

2/6/2019  
TCPLV502L.tc\_pid25a.dgn  
HNTB

**HNTB** HNTB NORTH CAROLINA, P.C.  
343 E. Six Forks Road, Suite 200  
Raleigh, North Carolina 27609  
NC License No: C-1554

APPROVED: *Helen Skyy*  
DATE: 2/6/2019  
SEAL  
NORTH CAROLINA PROFESSIONAL ENGINEER SEAL 042517 HELEN SKYY

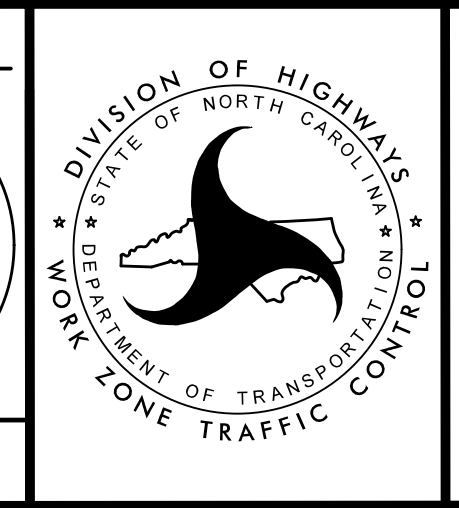

TRANSPORTATION  
MANAGEMENT PLAN  
  
PHASE IA  
DETAIL

DOCUMENT NOT CONSIDERED FINAL  
UNLESS ALL SIGNATURES COMPLETED

REPLACE PAVEMENT MARKING IN EXISTING PATTERN.

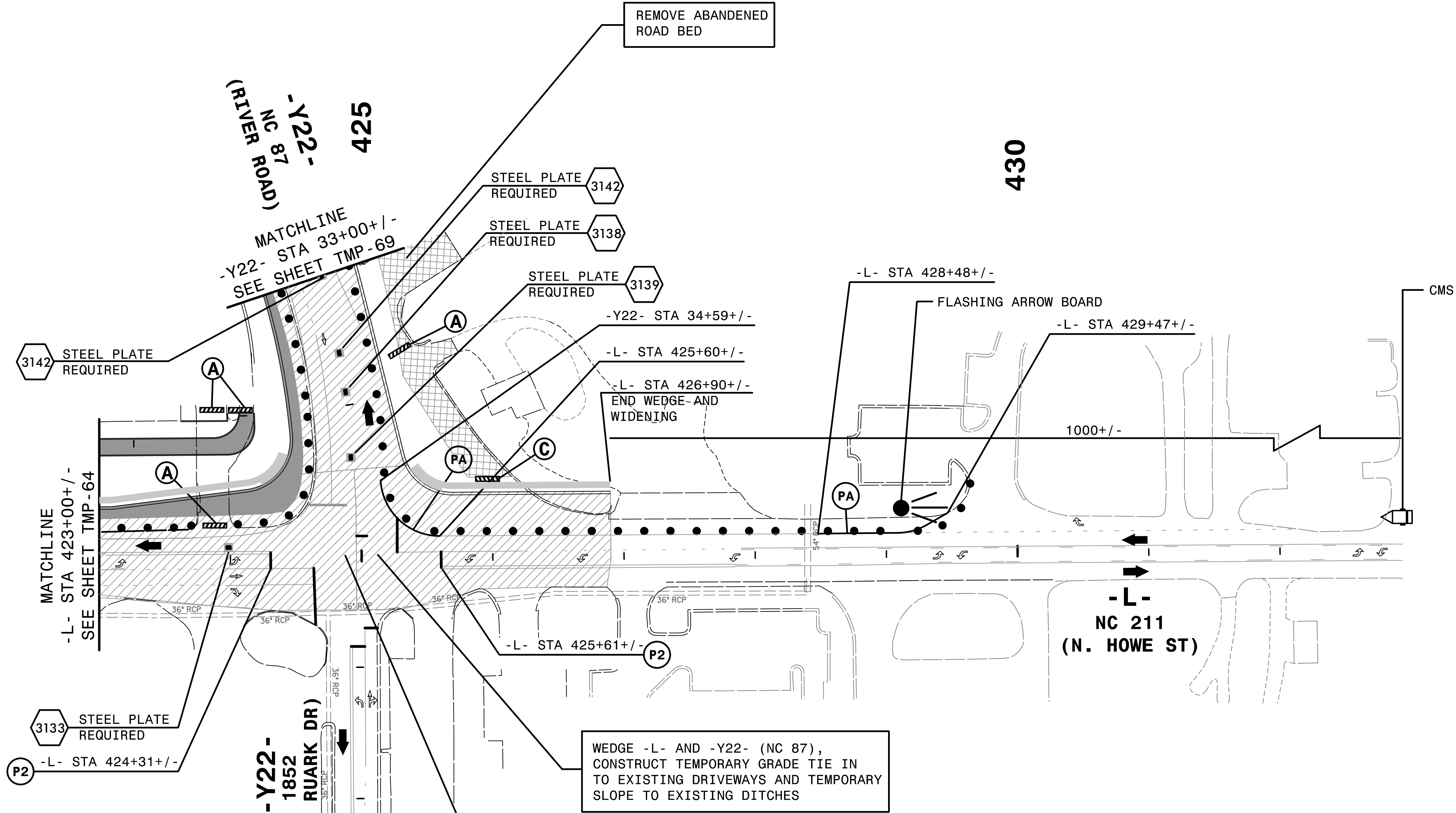

MESSAGE NO. 1	MESSAGE NO. 2
RIGHT TURN CLOSED	TURN AT SIGNAL
CHANGEABLE MESSAGE SIGN	

NOTE: USE RECOMMENDED MESSAGE OR MESSAGE DETERMINED BY THE ENGINEER

WEDGE -L- AND -Y22- (NC 87), CONSTRUCT TEMPORARY GRADE TIE IN TO EXISTING DRIVEWAYS AND TEMPORARY SLOPE TO EXISTING DITCHES

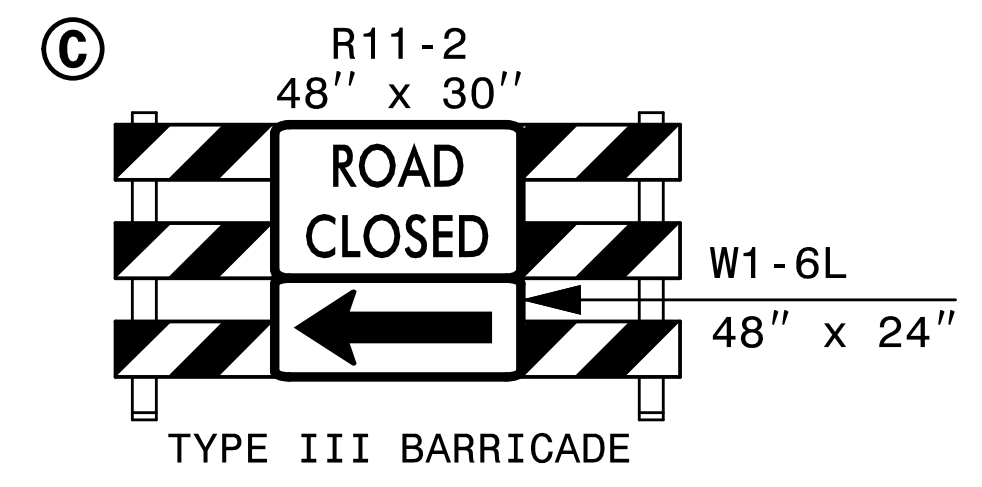
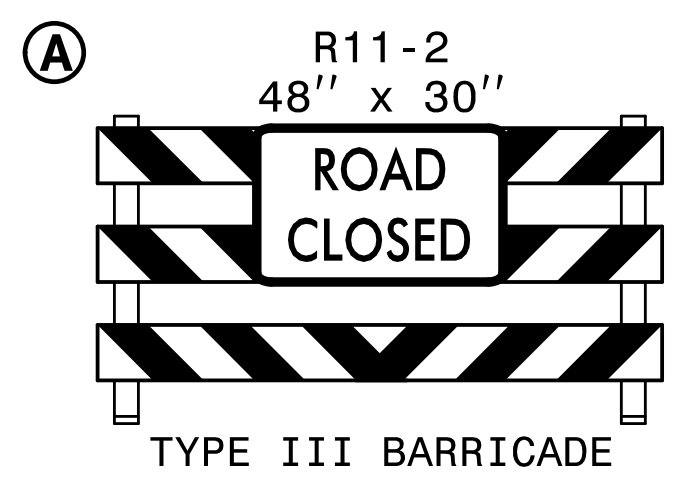

2/6/2019  
HNTB

**HNTB** HNTB NORTH CAROLINA, P.C.  
343 E. Six Forks Road, Suite 200  
Raleigh, North Carolina 27609  
NC License No: C-1554

APPROVED: *Helen Skyy*  
DATE: 2/6/2019  
SEAL

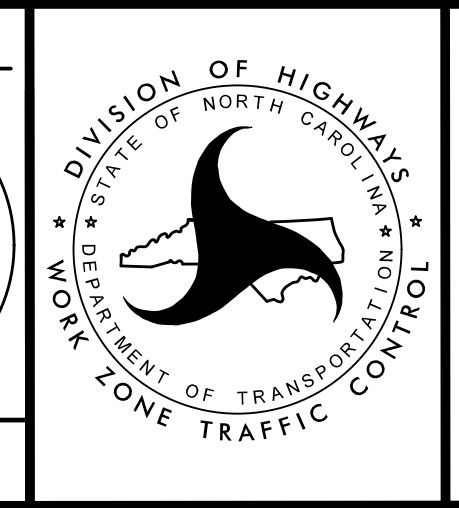

TRANSPORTATION  
MANAGEMENT PLAN  
  
PHASE IA  
DETAIL

DOCUMENT NOT CONSIDERED FINAL UNLESS ALL SIGNATURES COMPLETED



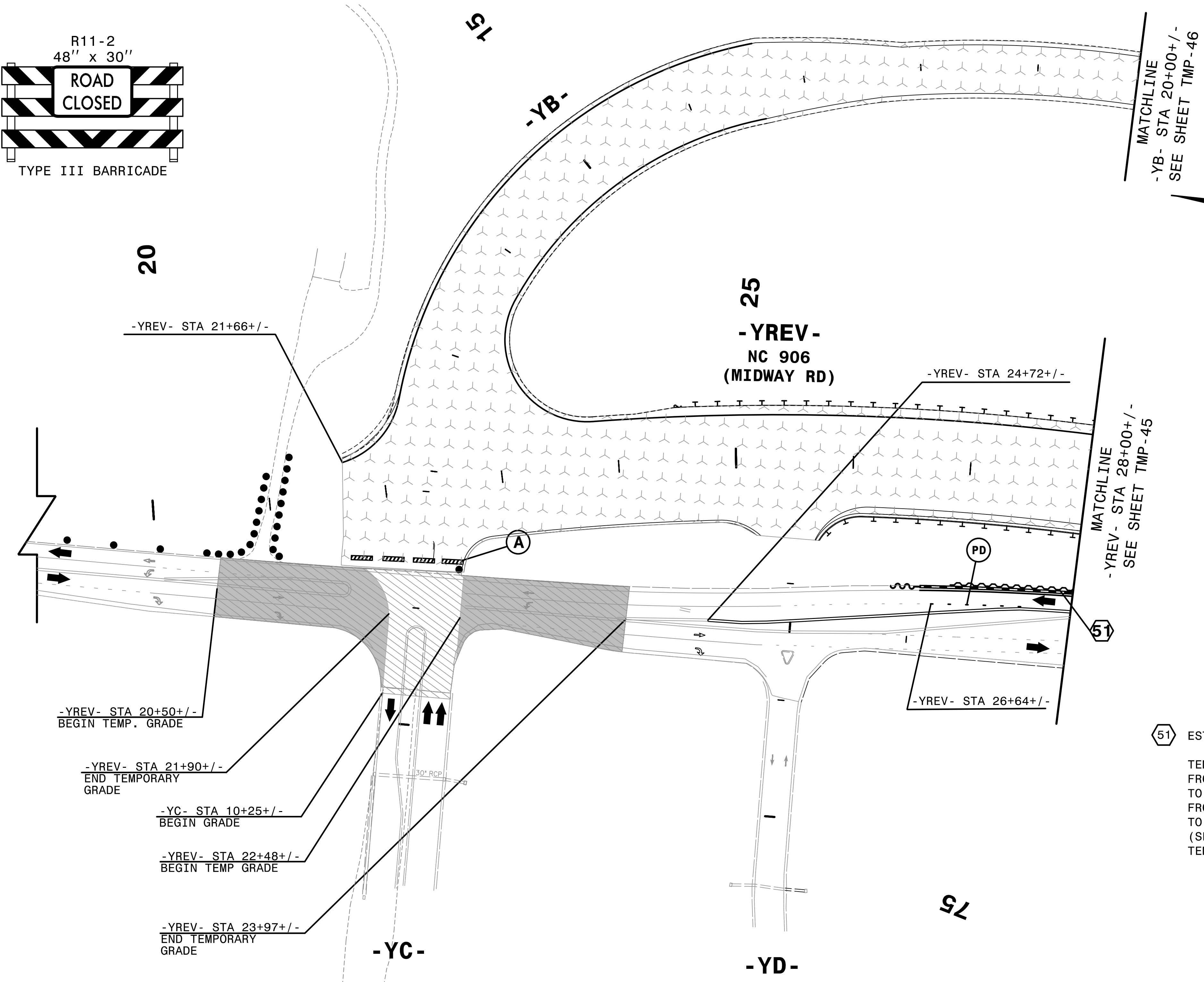
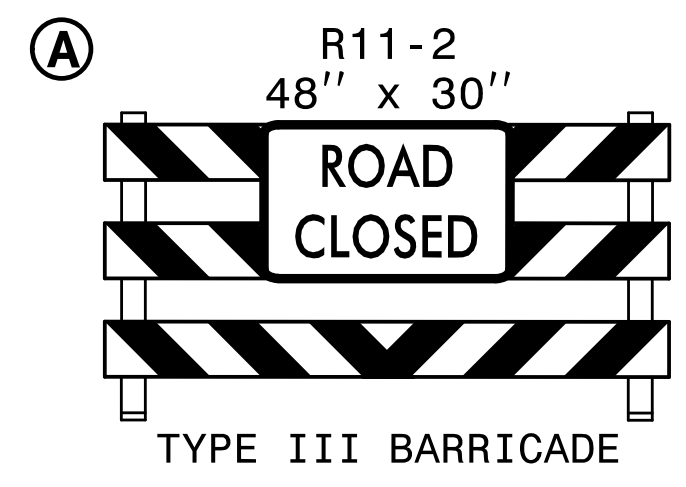

51 EST QUANTITY = 3380 SF

TEMPORARY SHORING  
FROM -YREV- STA 26+90.07+/-, 94.36' RT  
TO -YREV- STA 28+41.36, 86.36' RT  
FROM -YREV- STA 28+41.36, 86.36' RT  
TO -YREV- STA 30+37.27+/-, 65.17' RT  
(SEE SHEET TMP-2G FOR  
TEMPORARY SHORING NOTES)

4:53:56 PM  
\\TCPL-5021\cpl\d28a.dgn  
\$\$\$\$\$USERNAME\$\$\$\$\$

REPLACE PAVEMENT MARKING IN EXISTING PATTERN.

**HNTB** HNTB NORTH CAROLINA, P.C.  
343 E. Six Forks Road, Suite 200  
Raleigh, North Carolina 27609  
NC License No: C-1554

APPROVED: *Helen Shyu*  
DATE: 9/9/2021

SEAL

SEAL  
042517  
ENGINEER  
HELEN SHYU

DOCUMENT NOT CONSIDERED FINAL  
UNLESS ALL SIGNATURES COMPLETED

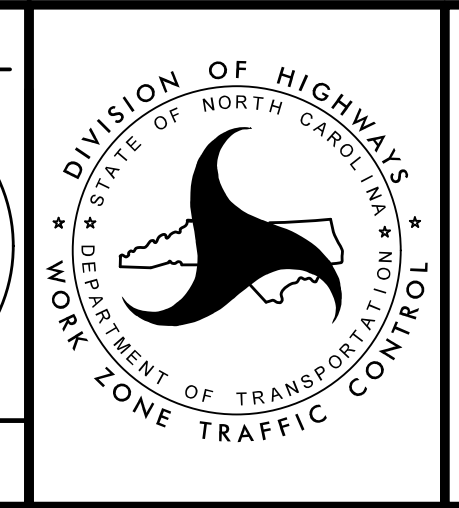

TRANSPORTATION  
MANAGEMENT PLAN

PHASE IA  
DETAIL

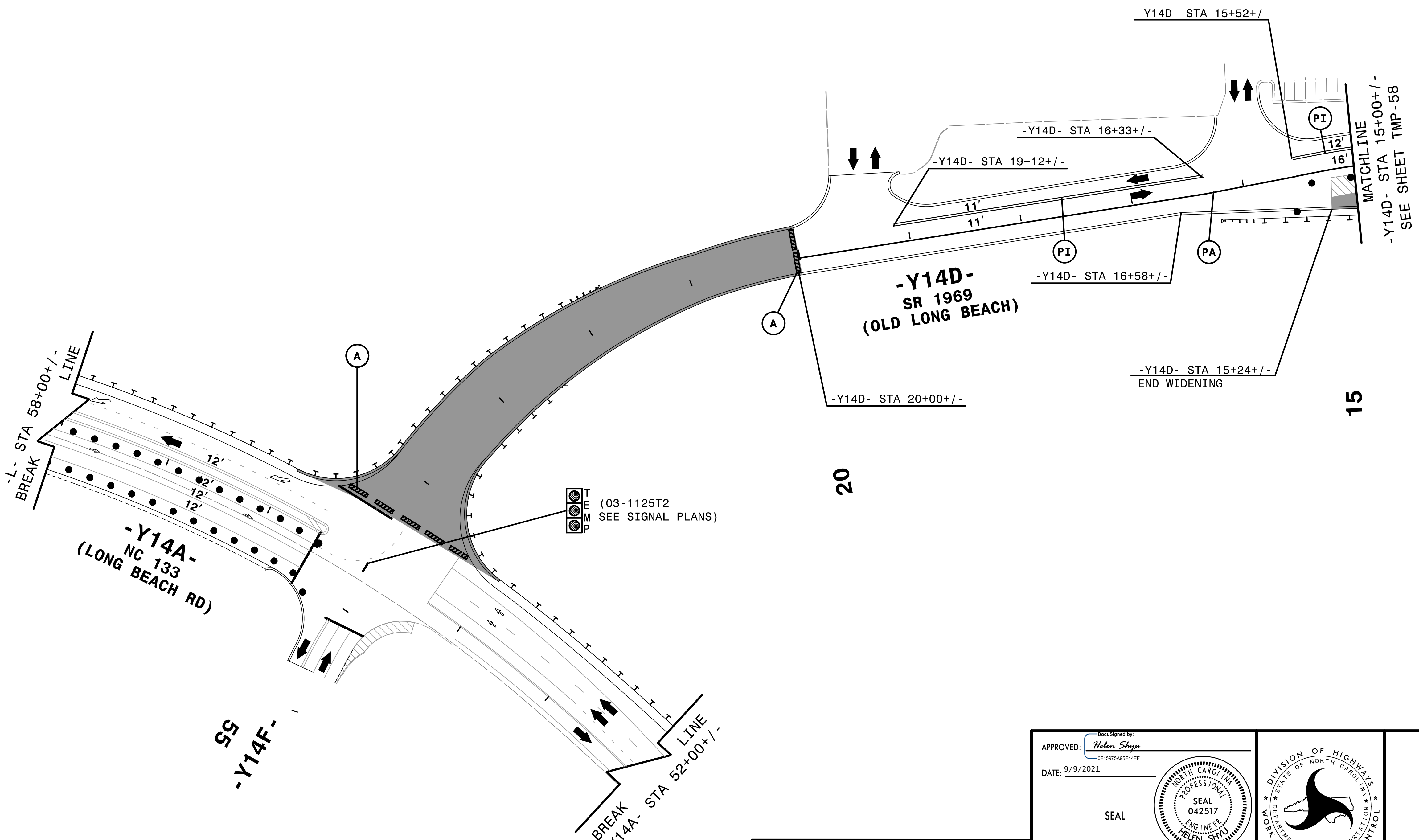
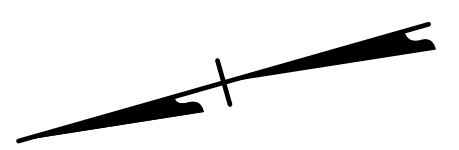
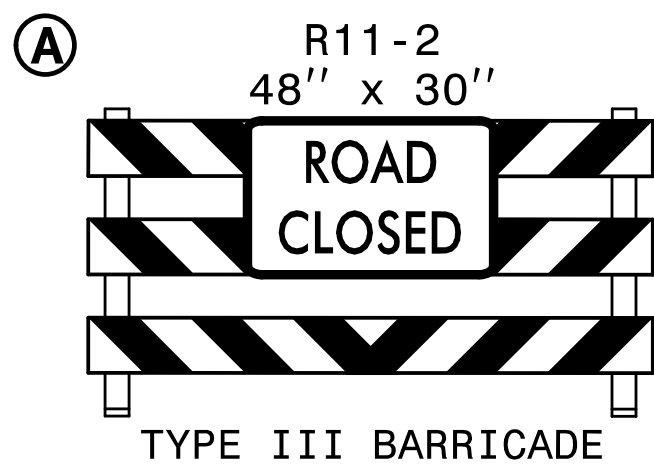

(03-1125T2  
SEE SIGNAL PLANS)

4:53:59 PM  
\\TCFV\5021\TC\_pid35a.dgn  
\$\$\$\$\$USERNAME\$\$\$\$\$

**HNTB** HNTB NORTH CAROLINA, P.C.  
343 E. Six Forks Road, Suite 200  
Raleigh, North Carolina 27609  
NC License No: C-1554

APPROVED: *Helen Shyu*  
DATE: 9/9/2021  
SEAL  
DOCUMENT NOT CONSIDERED FINAL  
UNLESS ALL SIGNATURES COMPLETED

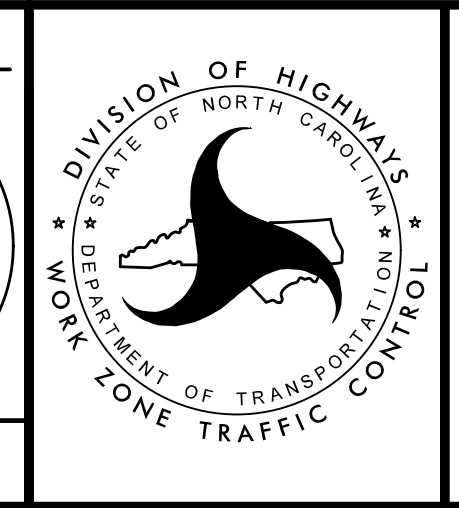

TRANSPORTATION  
MANAGEMENT PLAN  
PHASE 1A  
DETAIL

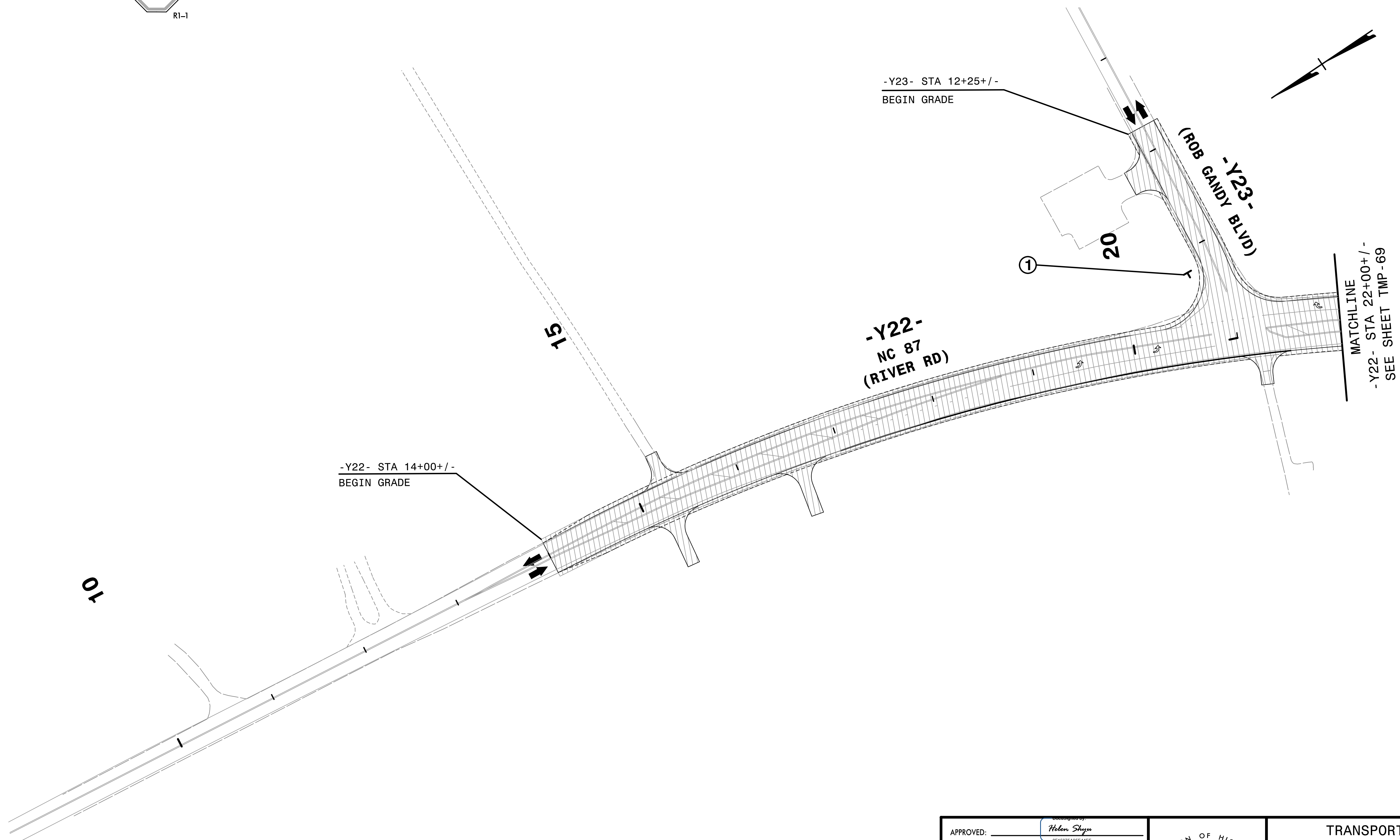
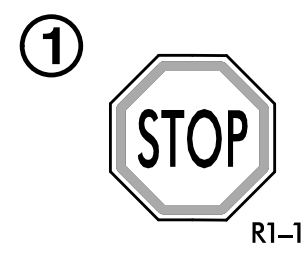

REPLACE PAVEMENT MARKING IN EXISTING PATTERN.

2/6/2019  
 HNTB  
 HNTB

**HNTB** HNTB NORTH CAROLINA, P.C.  
 343 E. Six Forks Road, Suite 200  
 Raleigh, North Carolina 27609  
 NC License No: C-1554

APPROVED: *Helen Shyu*  
 DATE: 2/6/2019  
 SEAL  
 HNTB

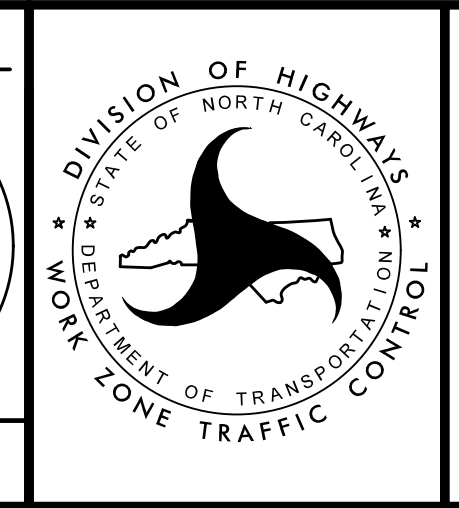

TRANSPORTATION  
 MANAGEMENT PLAN  
 PHASE IA  
 DETAIL

DOCUMENT NOT CONSIDERED FINAL  
 UNLESS ALL SIGNATURES COMPLETED

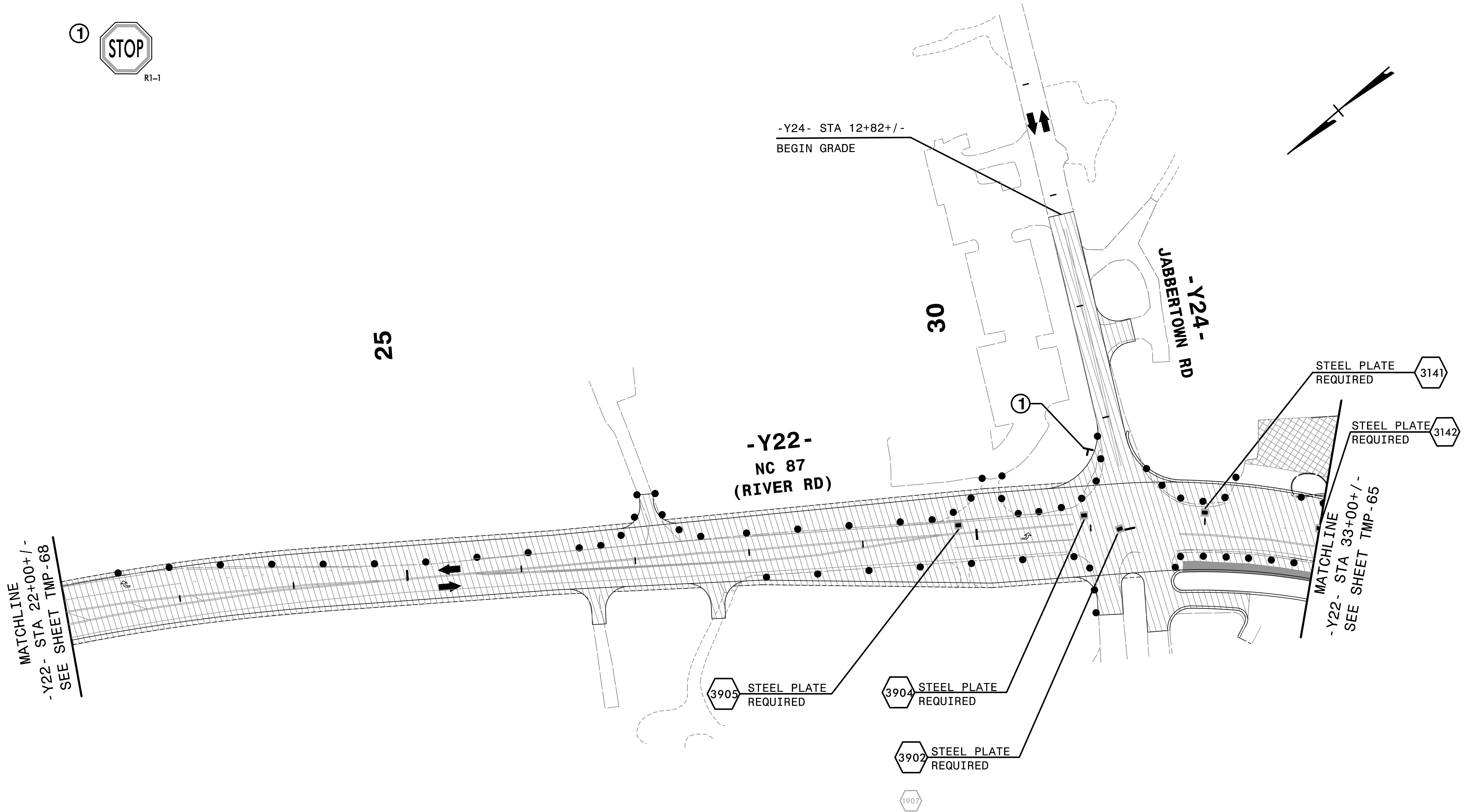

REPLACE PAVEMENT MARKING IN EXISTING PATTERN.

2/6/2019  
HNTB

**HNTB** HNTB NORTH CAROLINA, P.C.  
343 E. Six Forks Road, Suite 200  
Raleigh, North Carolina 27609  
NC License No: C-1554

APPROVED: *Helen Shyu*  
DATE: 2/6/2019

SEAL

PROFESSIONAL SEAL  
042517  
ENGINEER  
HELEN SHYU

DOCUMENT NOT CONSIDERED FINAL  
UNLESS ALL SIGNATURES COMPLETED

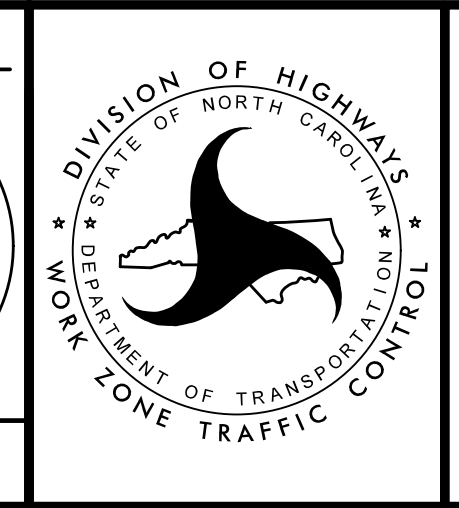

TRANSPORTATION  
MANAGEMENT PLAN

PHASE IA  
DETAIL

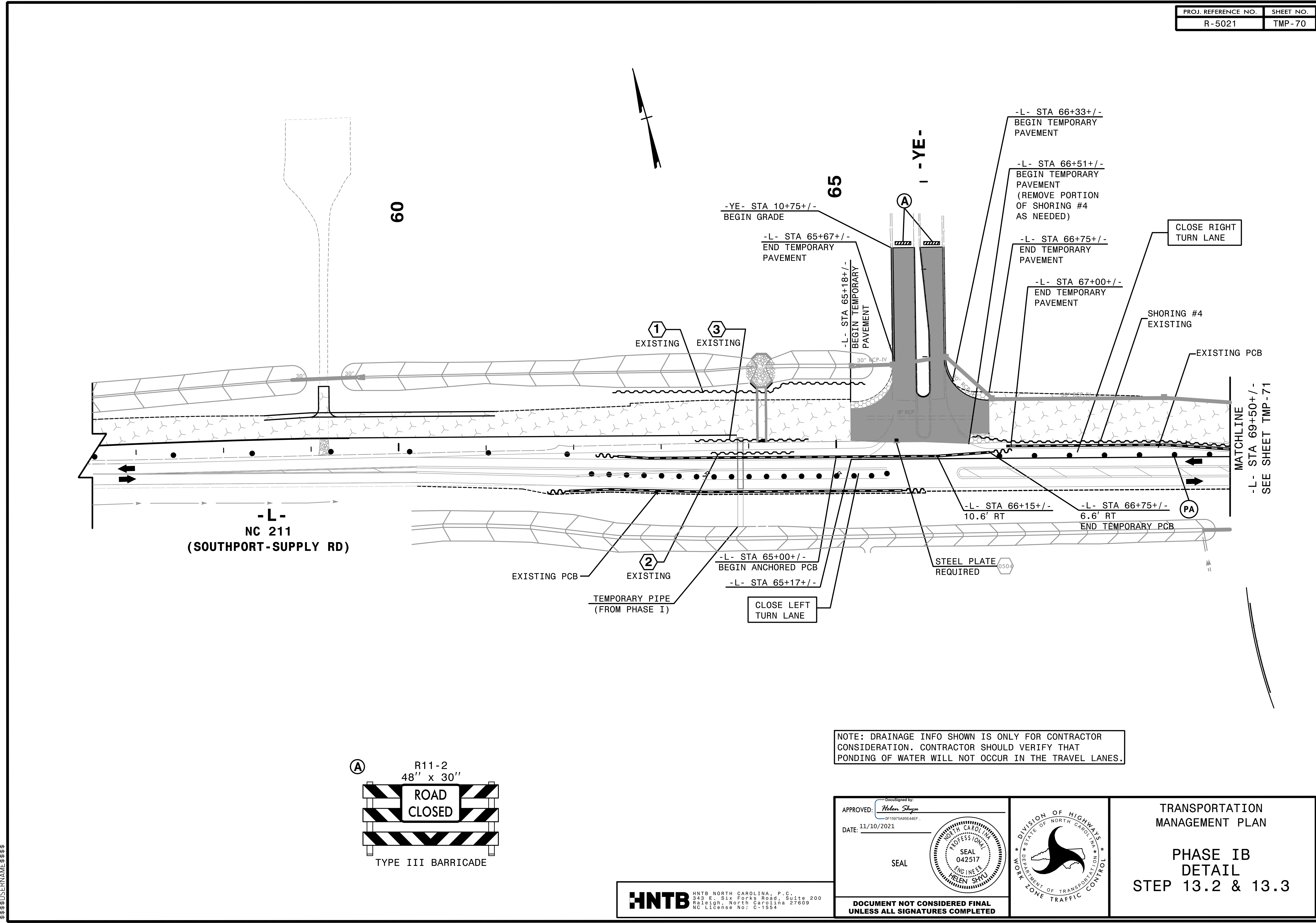

-L-  
NC 211  
(SOUTHPORT-SUPPLY RD)

EXISTING PCB  
EXISTING  
TEMPORARY PIPE  
(FROM PHASE I)  
CLOSE LEFT  
TURN LANE

-L- STA 65+00+/-  
BEGIN ANCHORED PCB  
-L- STA 65+17+/-  
CLOSE LEFT  
TURN LANE

-L- STA 66+15+/-  
10.6' RT  
STEEL PLATE  
REQUIRED  
-L- STA 66+75+/-  
6.6' RT  
END TEMPORARY PCB

-L- STA 66+33+/-  
BEGIN TEMPORARY  
PAVEMENT  
-L- STA 66+51+/-  
BEGIN TEMPORARY  
PAVEMENT  
(REMOVE PORTION  
OF SHORING #4  
AS NEEDED)  
-L- STA 66+75+/-  
END TEMPORARY  
PAVEMENT  
-L- STA 67+00+/-  
END TEMPORARY  
PAVEMENT

CLOSE RIGHT  
TURN LANE

SHORING #4  
EXISTING

EXISTING PCB

MATCHLINE  
-L- STA 69+50+/-  
SEE SHEET TMP-71

NOTE: DRAINAGE INFO SHOWN IS ONLY FOR CONTRACTOR CONSIDERATION. CONTRACTOR SHOULD VERIFY THAT PONDING OF WATER WILL NOT OCCUR IN THE TRAVEL LANES.

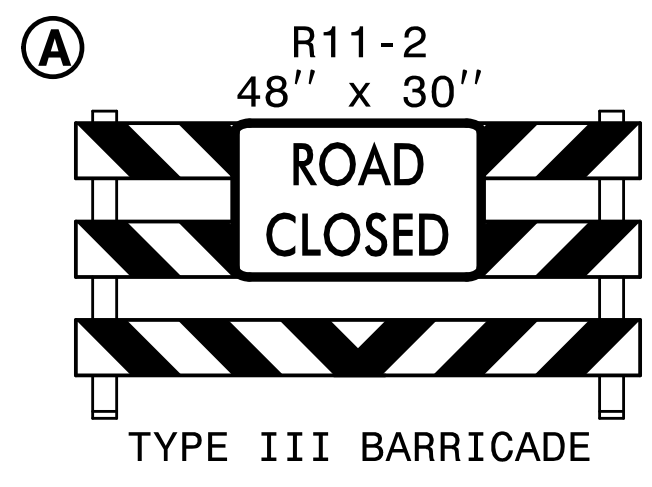

**HNTB** HNTB NORTH CAROLINA, P.C.  
343 E. Six Forks Road, Suite 200  
Raleigh, North Carolina 27609  
NC License No: C-1554

APPROVED: *Helen Shyu*  
DATE: 11/10/2021  
SEAL  
DOCUMENT NOT CONSIDERED FINAL  
UNLESS ALL SIGNATURES COMPLETED

TRANSPORTATION  
MANAGEMENT PLAN  
PHASE IB  
DETAIL  
STEP 13.2 & 13.3

4:56:24 PM  
\\TCFV\F5021\_Tc\_pid2b.dgn  
\$\$\$\$\$USERNAME\$\$\$\$\$

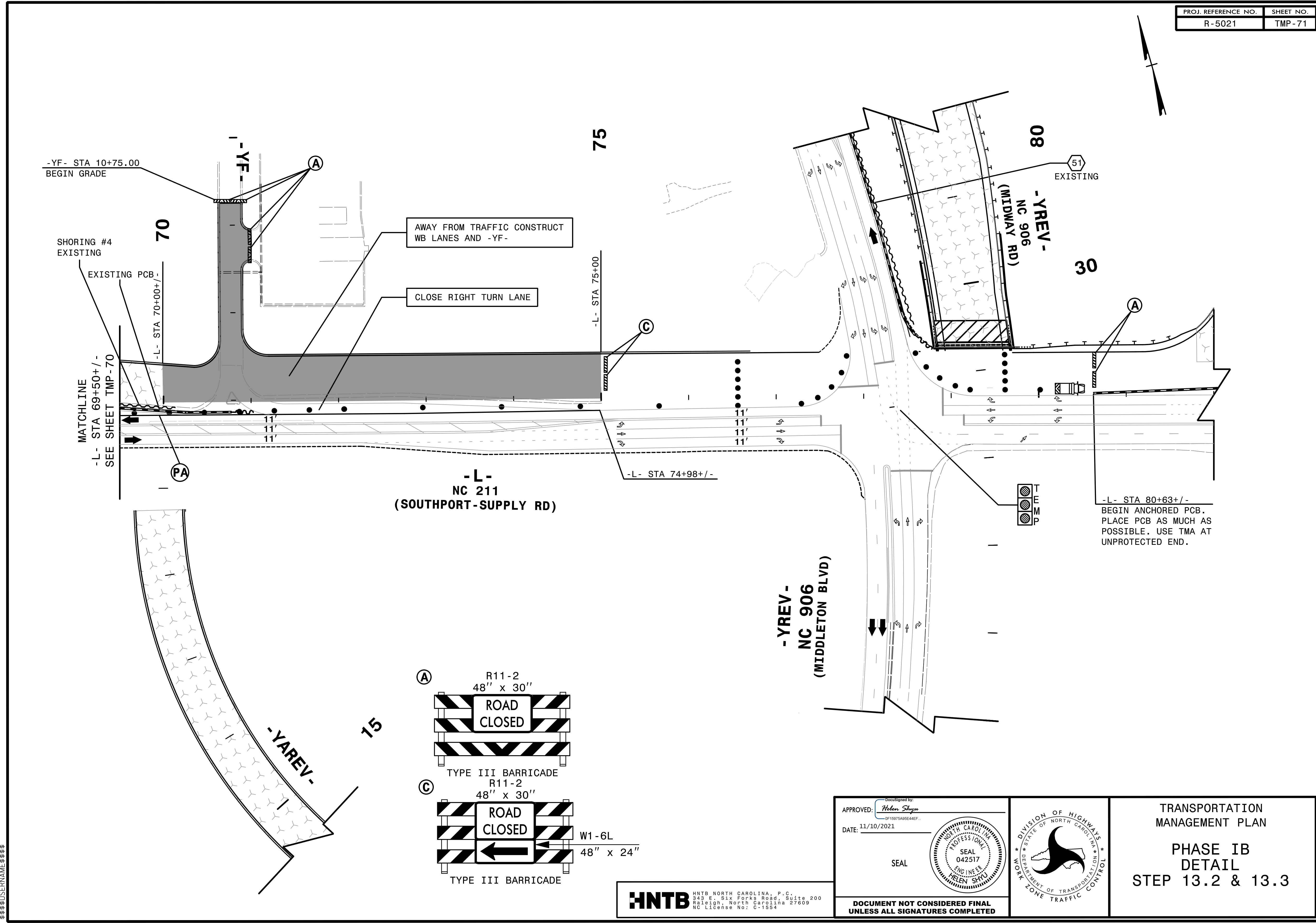

4:56:26 PM  
 \\TCF\...5021\_Tc\_pid3b.dgn  
 \$\$\$USERNAME\$\$\$

**HNTB** HNTB NORTH CAROLINA, P.C.  
 343 E. Six Forks Road, Suite 200  
 Raleigh, North Carolina 27609  
 NC License No: C-1554

APPROVED: *Helen Shyn*  
 DATE: 11/10/2021  
 SEAL  
 PROFESSIONAL ENGINEER  
 HELLEN SHYN  
 042517

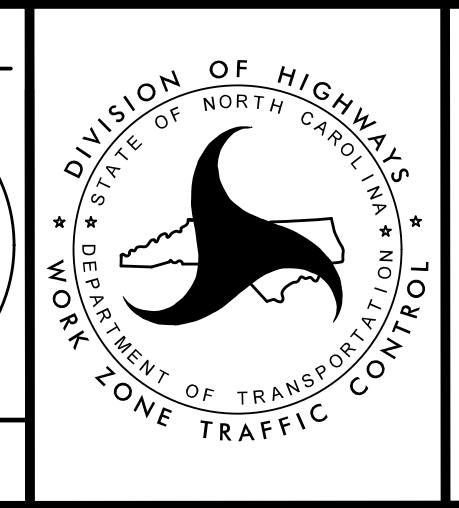

TRANSPORTATION  
 MANAGEMENT PLAN  
 PHASE IB  
 DETAIL  
 STEP 13.2 & 13.3

DOCUMENT NOT CONSIDERED FINAL  
 UNLESS ALL SIGNATURES COMPLETED

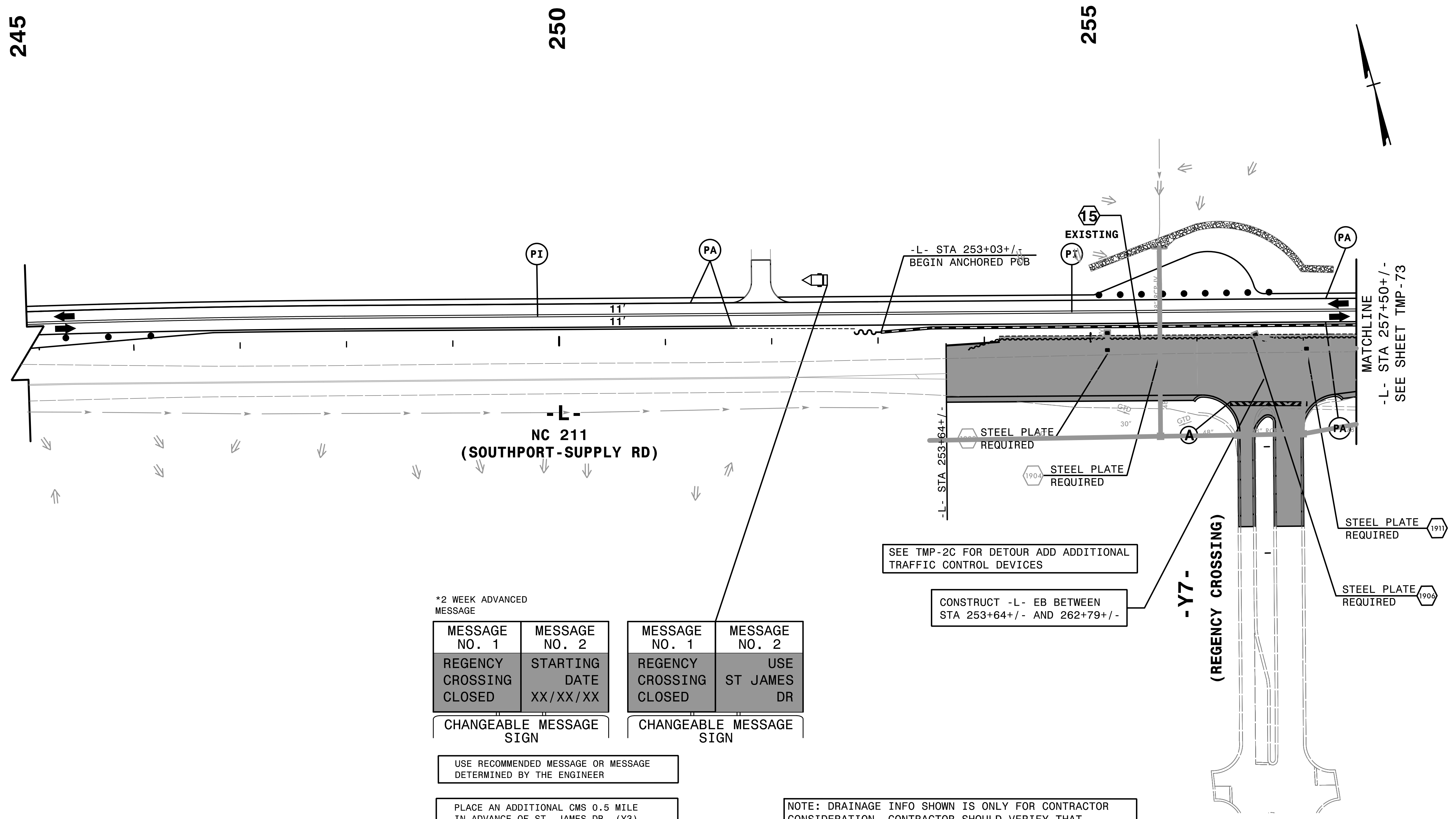

\*2 WEEK ADVANCED MESSAGE

MESSAGE NO. 1	MESSAGE NO. 2	MESSAGE NO. 1	MESSAGE NO. 2
REGENCY CROSSING CLOSED	STARTING DATE XX/XX/XX	REGENCY CROSSING CLOSED	USE ST JAMES DR

CHANGEABLE MESSAGE SIGN      CHANGEABLE MESSAGE SIGN

USE RECOMMENDED MESSAGE OR MESSAGE DETERMINED BY THE ENGINEER

PLACE AN ADDITIONAL CMS 0.5 MILE IN ADVANCE OF ST. JAMES DR. (Y3) SEE TMP- 2C

NOTE: DRAINAGE INFO SHOWN IS ONLY FOR CONTRACTOR CONSIDERATION. CONTRACTOR SHOULD VERIFY THAT PONDING OF WATER WILL NOT OCCUR IN THE TRAVEL LANES.

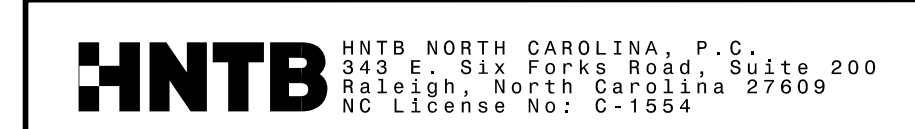
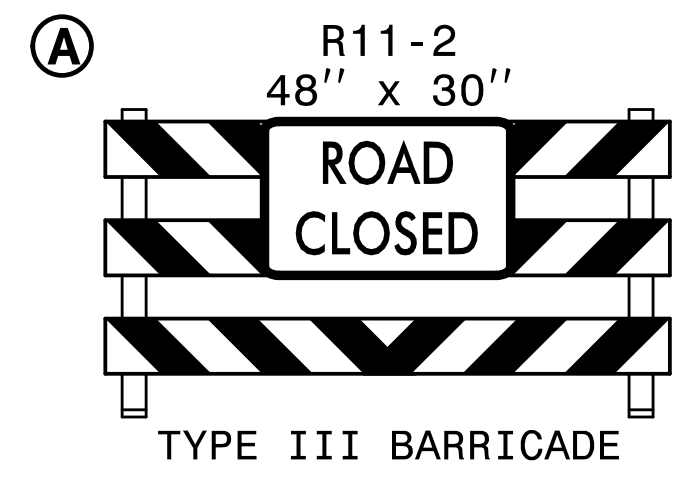

APPROVED: *Helen Shyu*  
DATE: 11/10/2021

SEAL

DOCUMENT NOT CONSIDERED FINAL UNLESS ALL SIGNATURES COMPLETED

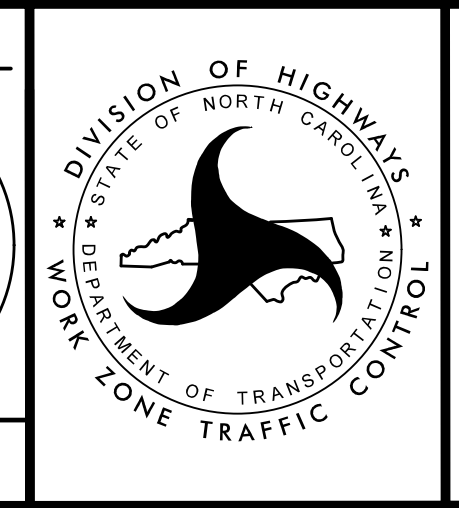

TRANSPORTATION MANAGEMENT PLAN

PHASE IB  
STEP 13.6  
DETAIL

4:56:29 PM  
...\\TCF\T5021\_Tc\_p\dl2e.dgn  
\$\$\$\$\$USERNAME\$\$\$\$\$

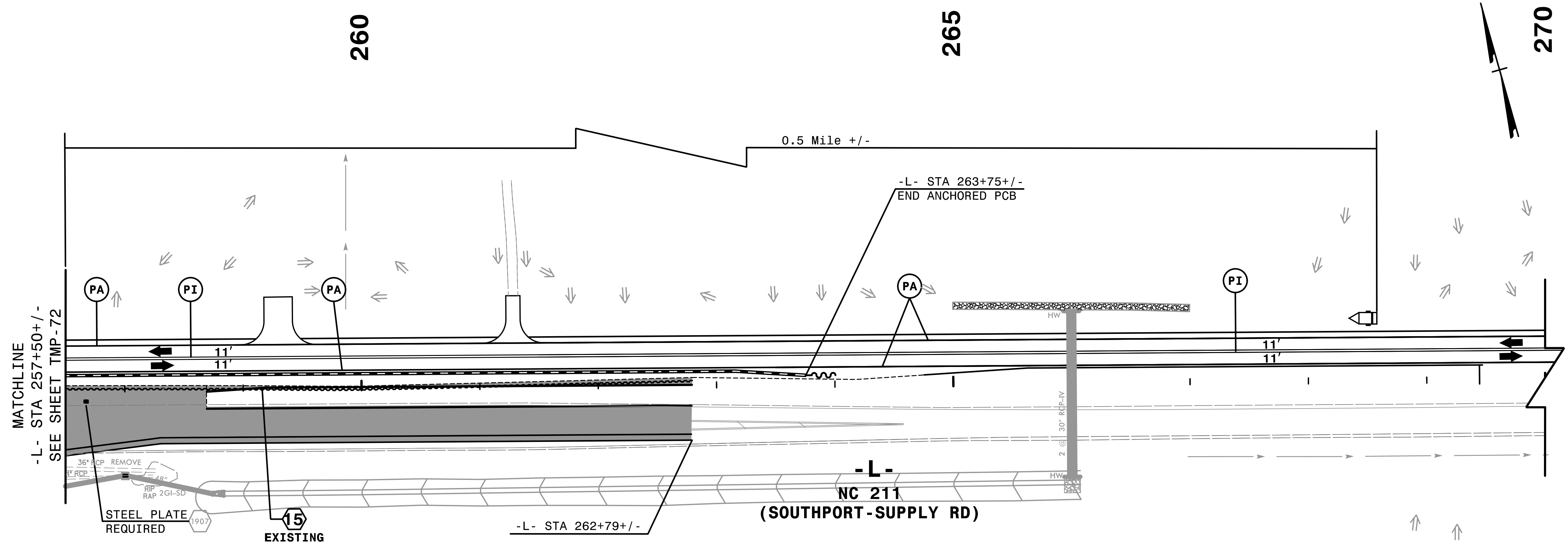

\*2 WEEK ADVANCED NOTICE MESSAGE

MESSAGE NO. 1	MESSAGE NO. 2
REGENCY CROSSING CLOSED	STARTING DATE XX/XX/XX

CHANGEABLE MESSAGE SIGN

MESSAGE NO. 1	MESSAGE NO. 2
REGENCY CROSSING CLOSED	USE ST JAMES DRIVE

CHANGEABLE MESSAGE SIGN

USE RECOMMENDED MESSAGE OR MESSAGE DETERMINED BY THE ENGINEER

NOTE: DRAINAGE INFO SHOWN IS ONLY FOR CONTRACTOR CONSIDERATION. CONTRACTOR SHOULD VERIFY THAT PONDING OF WATER WILL NOT OCCUR IN THE TRAVEL LANES.

4:56:32 PM  
 \\TCFV\5021\TC\pld\3e.dgn  
 \$\$\$USERNAME\$\$\$

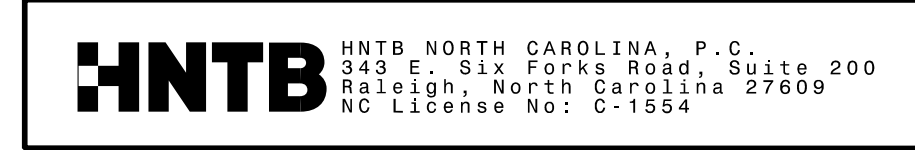

APPROVED: *Helen Shyu*  
 DATE: 11/10/2021  
 SEAL  
 HNTB PROFESSIONAL SEAL 042517  
 HELLEN SHYU  
 ENGINEER  
 NC License No: C-1554

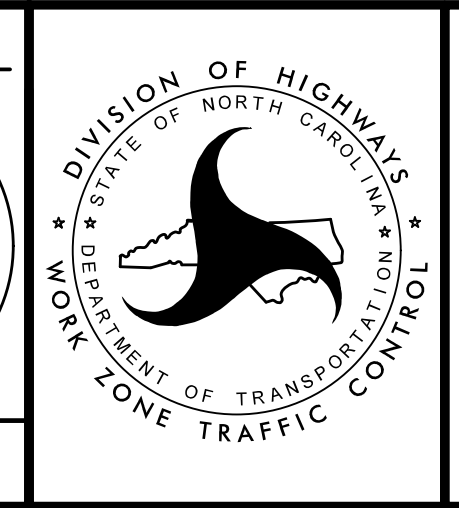

TRANSPORTATION MANAGEMENT PLAN  
 PHASE IB  
 STEP 13.6  
 DETAIL

DOCUMENT NOT CONSIDERED FINAL UNLESS ALL SIGNATURES COMPLETED





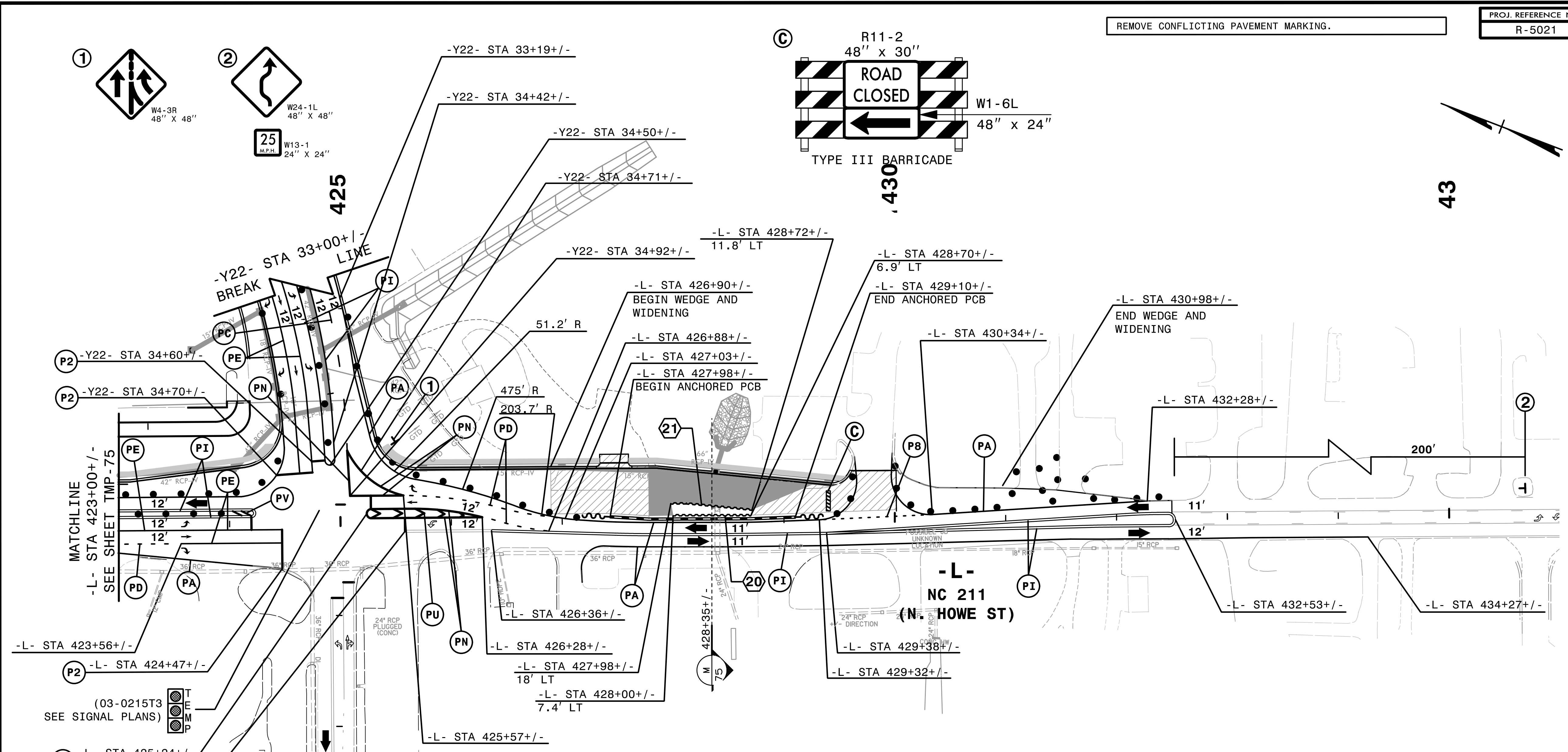

20 EST QUANTITY = 387 SF

TEMPORARY SHORING  
FROM -L- STA 428+00+/-, 7.4' LT  
TO -L- STA 428+70+/-, 6.9' LT

(SEE TMP-2G FOR  
TEMPORARY SHORING NOTES)

21 EST QUANTITY = 423 SF

TEMPORARY SHORING  
FROM -L- STA 427+98+/-, 18' LT  
TO -L- STA 428+12+/-, 18' LT AND  
FROM -L- STA 428+12+/-, 18' LT  
TO -L- STA 428+72+/-, 11.8' LT

(SEE TMP-2G FOR  
TEMPORARY SHORING NOTES)

NOTE: DRAINAGE INFO SHOWN IS ONLY FOR CONTRACTOR  
CONSIDERATION. CONTRACTOR SHOULD VERIFY THAT  
PONDING OF WATER WILL NOT OCCUR IN THE TRAVEL LANES.

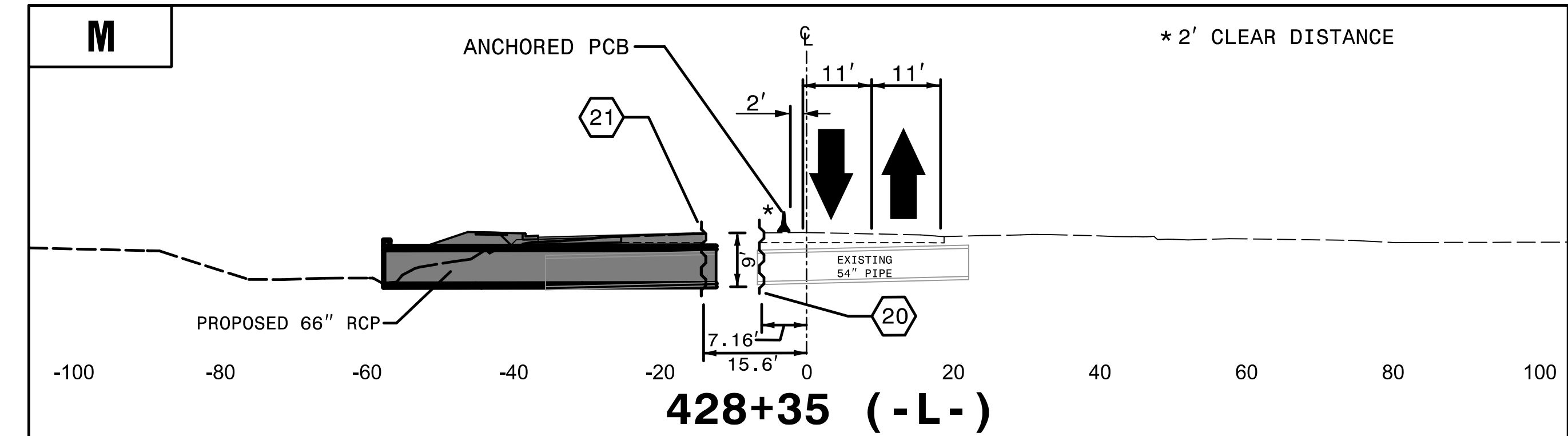

4:56:40 PM  
\\TCFV15021\_Tc\_p\d26b.dgn  
\$\$\$\$\$USERNAME\$\$\$\$\$

**HNTB** HNTB NORTH CAROLINA, P.C.  
343 E. Six Forks Road, Suite 200  
Raleigh, North Carolina 27609  
NC License No: C-1554

APPROVED: *Helen Shyu*  
DATE: 11/10/2021  
SEAL  
PROFESSIONAL SEAL  
042517  
ENGINEER  
HELEN SHYU

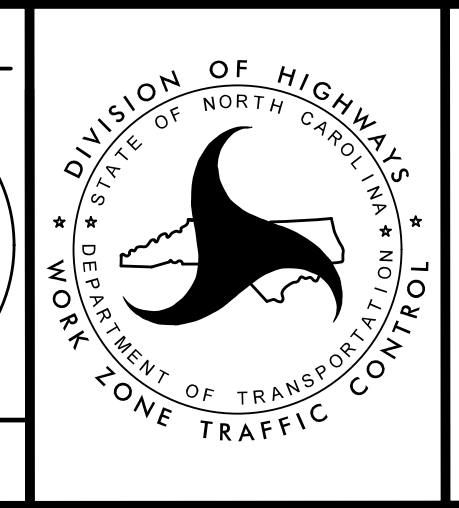

TRANSPORTATION  
MANAGEMENT PLAN  
PHASE IB  
STEP 16.4  
DETAIL

DOCUMENT NOT CONSIDERED FINAL  
UNLESS ALL SIGNATURES COMPLETED

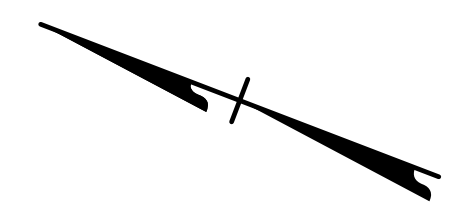
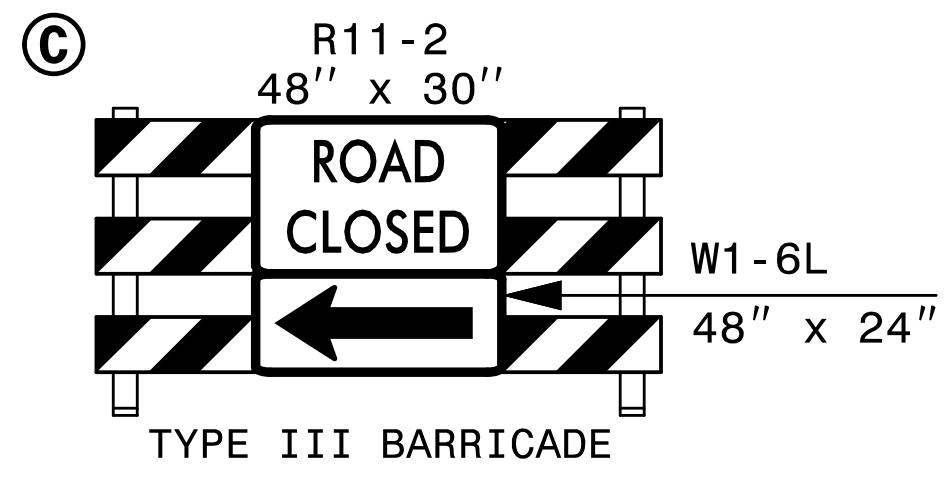
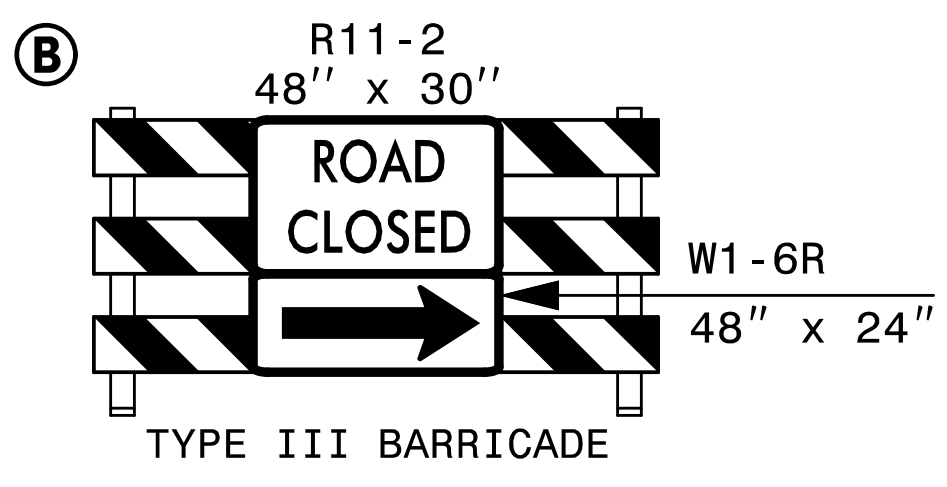
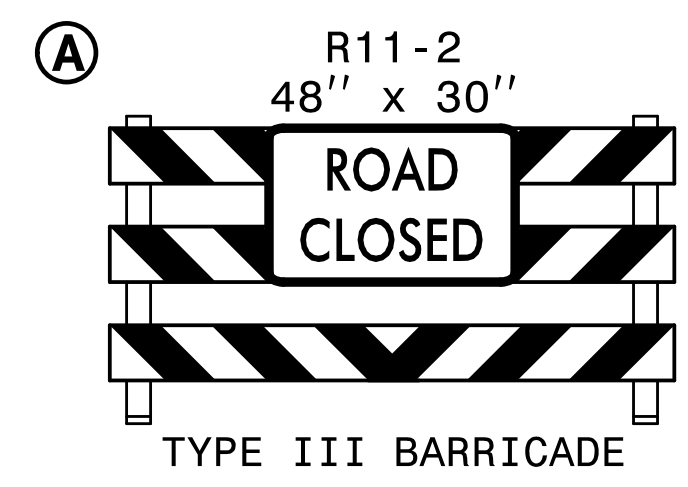
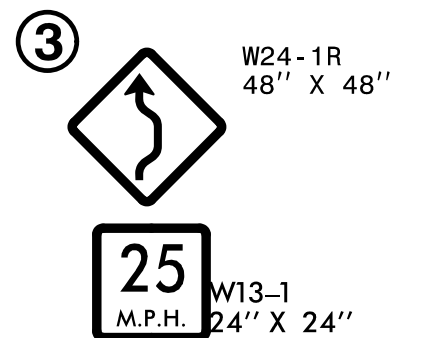
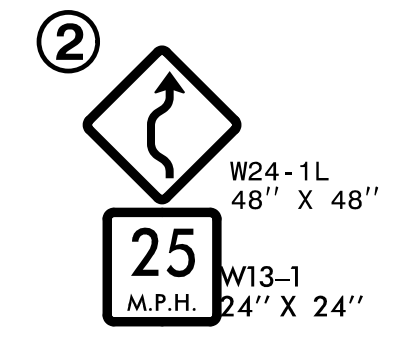

430

435

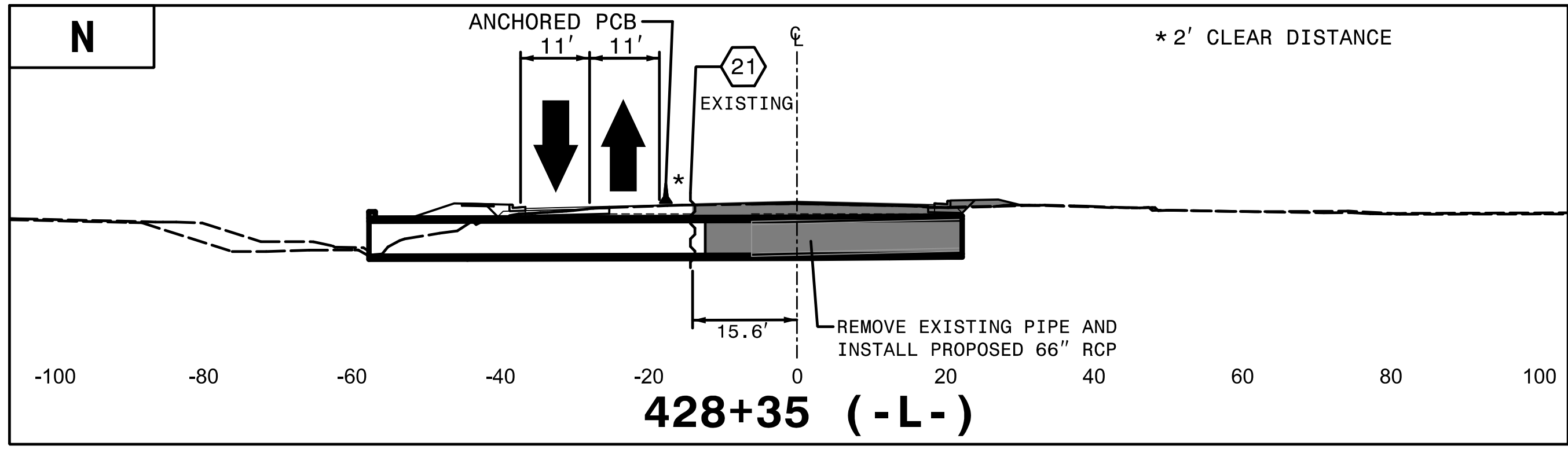
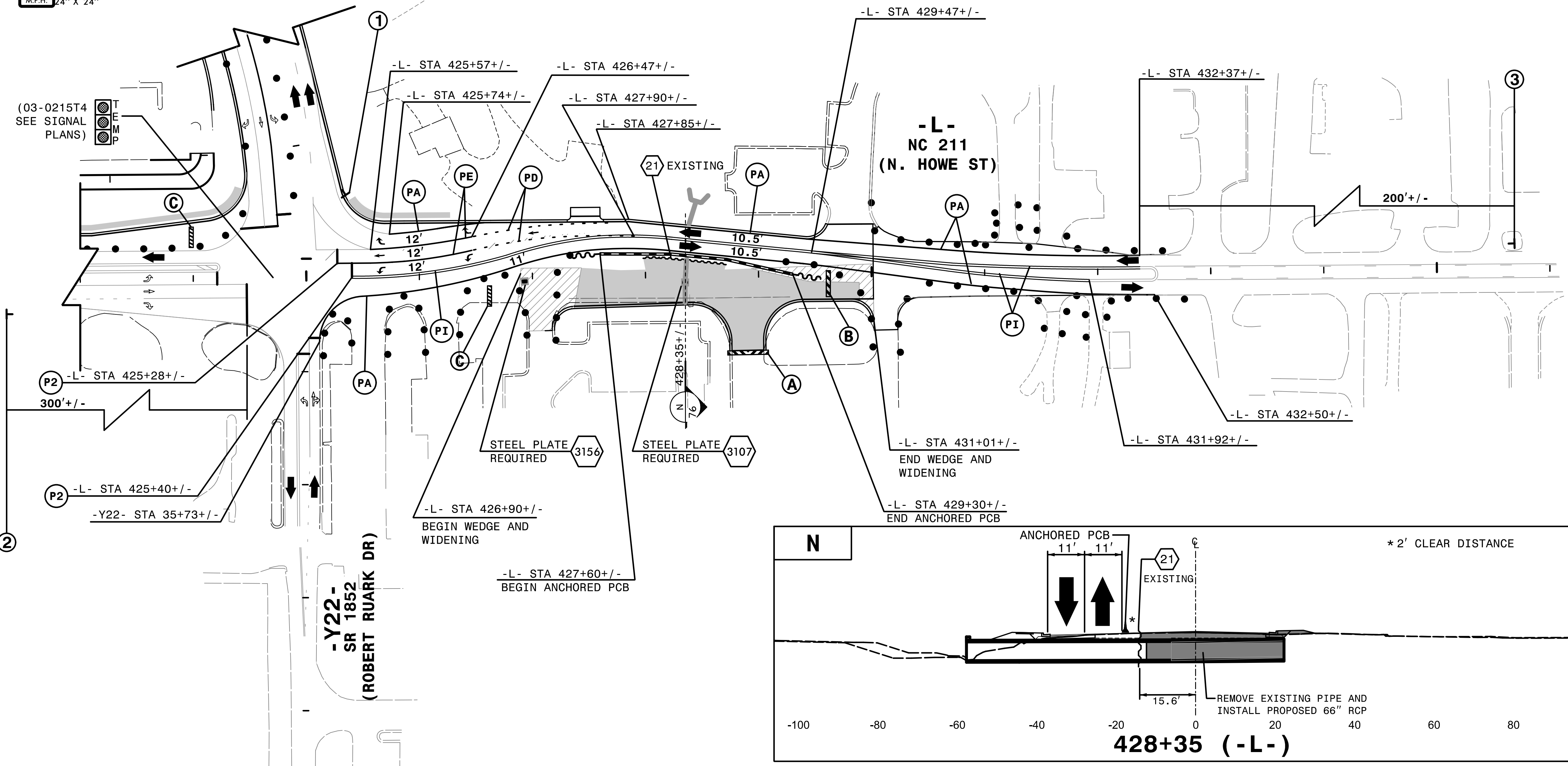

4:56:42 PM  
 \\TCFV15021\_Tc\_pid26d.dgn  
 \$\$\$USERNAME\$\$\$

REMOVE CONFLICTING PAVEMENT MARKING.

**HNTB** HNTB NORTH CAROLINA, P.C.  
 343 E. Six Forks Road, Suite 200  
 Raleigh, North Carolina 27609  
 NC License No: C-1554

APPROVED: *Helen Shyu*  
 DATE: 11/10/2021  
 SEAL  
 PROFESSIONAL ENGINEER  
 SEAL 042517  
 HELEN SHYU

DIVISION OF HIGHWAYS  
 NORTH CAROLINA  
 DEPARTMENT OF TRANSPORTATION  
 WORK ZONE TRAFFIC CONTROL

TRANSPORTATION  
 MANAGEMENT PLAN  
 PHASE IB  
 STEP 16.4  
 DETAIL

DOCUMENT NOT CONSIDERED FINAL  
 UNLESS ALL SIGNATURES COMPLETED

PROJ. REFERENCE NO.	SHEET NO.
R-5021	TMP-77

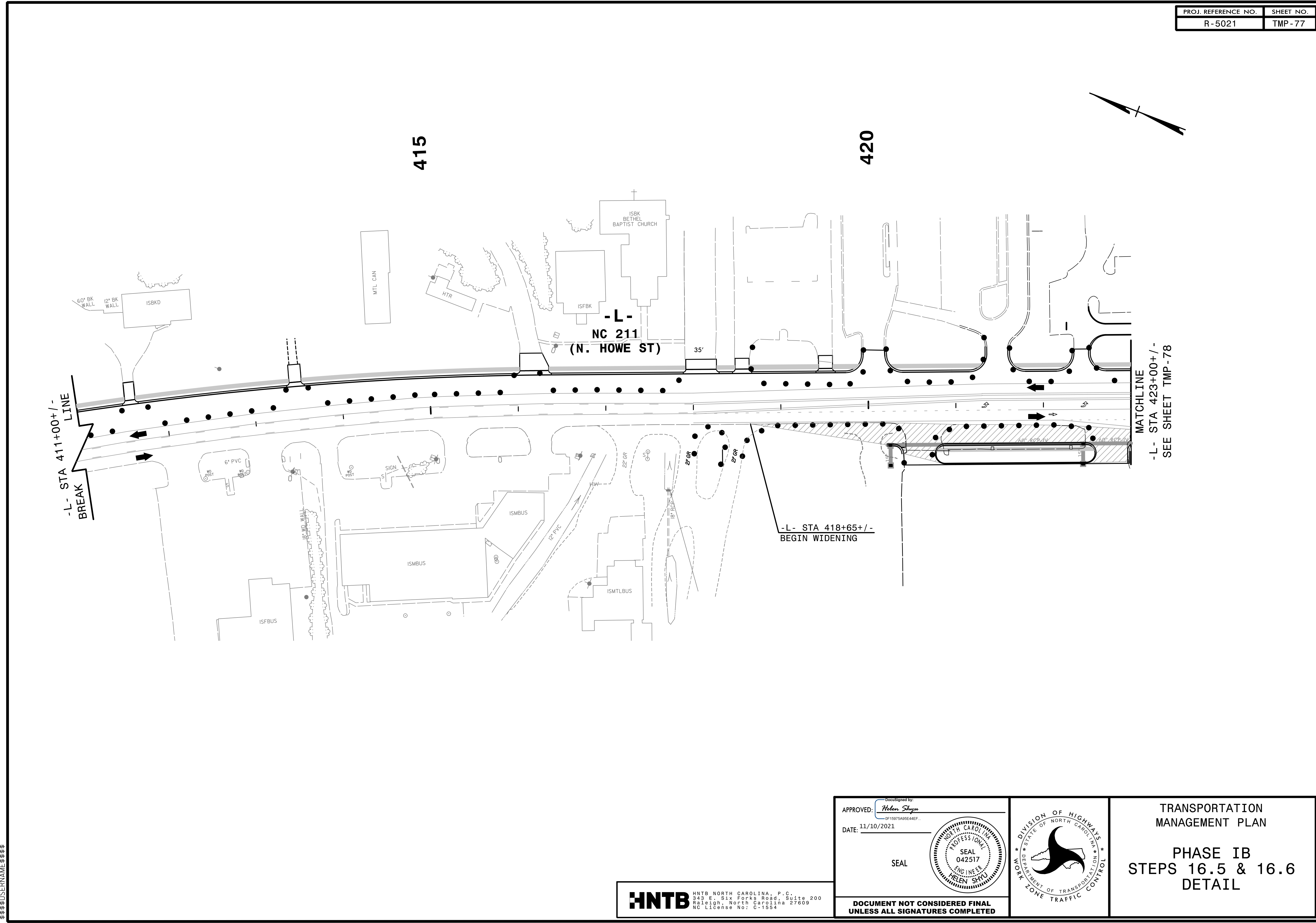

4:56:47 PM  
 \\TCF\15021\1021\1021\1021.dgn  
 \$\$\$USERNAME\$\$\$

**HNTB** HNTB NORTH CAROLINA, P.C.  
 343 E. Six Forks Road, Suite 200  
 Raleigh, North Carolina 27609  
 NC License No: C-1554

APPROVED: *Helen Shyu*  
 DATE: 11/10/2021  
 SEAL  
 DOCUMENT NOT CONSIDERED FINAL  
 UNLESS ALL SIGNATURES COMPLETED

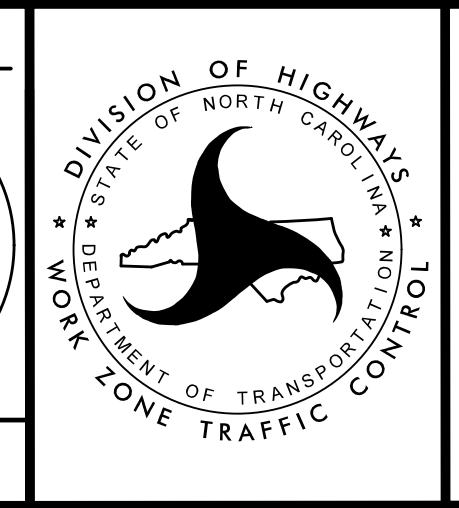
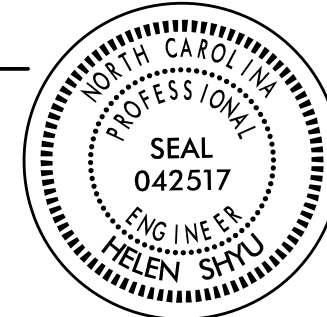

TRANSPORTATION  
 MANAGEMENT PLAN  
 PHASE IB  
 STEPS 16.5 & 16.6  
 DETAIL