

**CONCRETE PARAPET PLAN**

NOTE: EDGE OF SLAB NOT SHOWN FOR CLARITY

**NOTES:**

PARAPET IN A CONTINUOUS UNIT SHALL NOT BE CAST UNTIL ALL SLAB CONCRETE IN THE UNIT HAS BEEN CAST AND HAS REACHED A MINIMUM COMPRESSIVE STRENGTH OF 3,000 PSI.

ALL REINFORCING STEEL IN PARAPET SHALL BE EPOXY COATED.

GROOVED CONTRACTION JOINTS, 1/2" IN DEPTH, SHALL BE TOOLED IN ALL EXPOSED FACES OF THE PARAPET AND IN ACCORDANCE WITH ARTICLE 825-10(B) OF THE STANDARD SPECIFICATIONS. THE CONTRACTION JOINT SHALL BE LOCATED AT EACH THIRD POINT BETWEEN PARAPET EXPANSION JOINTS. ONLY ONE CONTRACTION JOINT IS REQUIRED AT MIDPOINT OF PARAPET SEGMENTS LESS THAN 20 FEET IN LENGTH AND NO CONTRACTION JOINTS ARE REQUIRED FOR THOSE SEGMENTS LESS THAN 10 FEET IN LENGTH.

FOR CONCRETE PARAPET AND END POST BILL OF MATERIAL, SEE SHEET 2 OF 2.

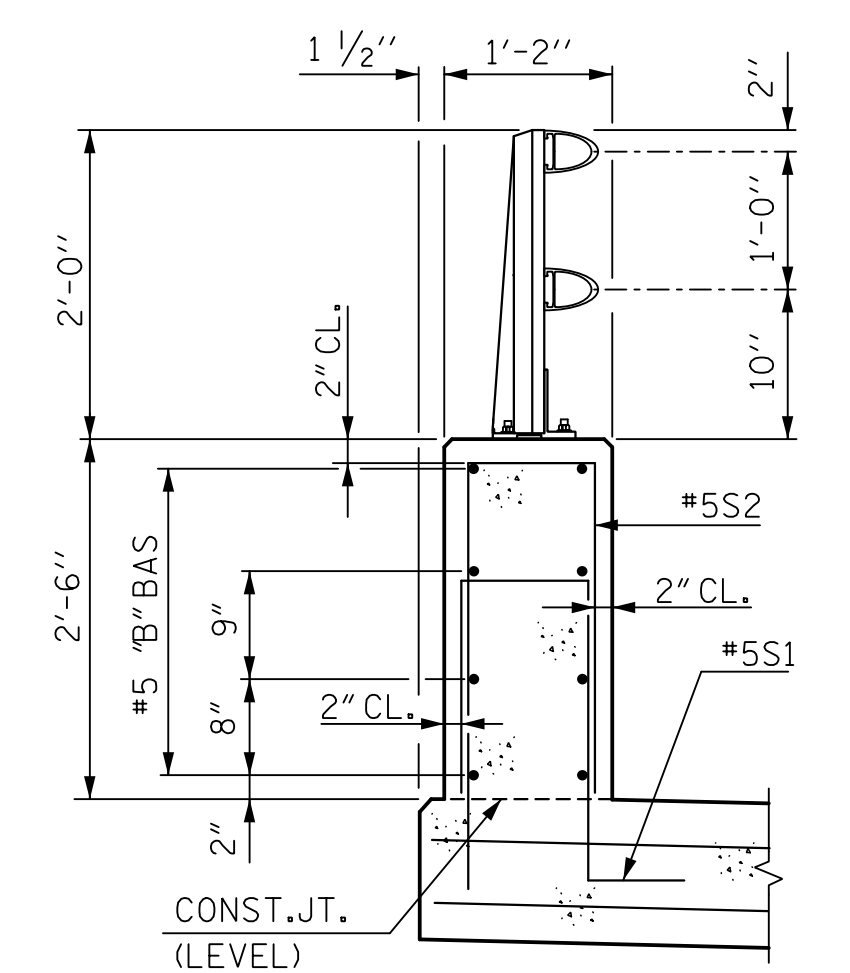

**SECTION THRU PARAPET AND RAIL**

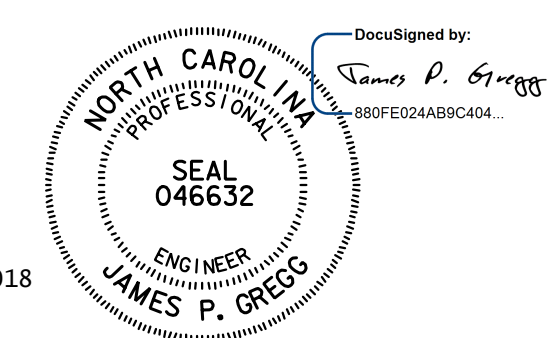

8/22/2018

**HNTB** HNTB NORTH CAROLINA, P.C.  
 NC License No. C-1554  
 343 E. Six Forks Rd., Suite 200, Raleigh, N.C. 27609

DRAWN BY: B. NEUPANE DATE: 8/17  
 CHECKED BY: B. EMAMI DATE: 9/17  
 DESIGN ENGINEER OF RECORD: J. GREGG DATE: 8/18

DWG. NO. 19

PROJECT NO. R-5021  
BRUNSWICK COUNTY  
 STATION: POC 390+15.00 -L-

SHEET 1 OF 2

STATE OF NORTH CAROLINA  
 DEPARTMENT OF TRANSPORTATION  
 RALEIGH

**SUPERSTRUCTURE**  
 CONCRETE PARAPET AND  
 END POST DETAILS  
 RIGHT LANE

REVISIONS						SHEET NO.
NO.	BY	DATE	NO.	BY	DATE	S6-19
1			3			TOTAL SHEETS
2			4			39