

STRUCTURAL STEEL NOTES

ALL INTERMEDIATE DIAPHRAGM STEEL AND CONNECTOR PLATES SHALL BE AASHTO M270 GRADE 50 OR APPROVED EQUAL.

TENSION ON THE ASTM A325 BOLTS THROUGH THE ANGLE MEMBER SHALL BE CALIBRATED USING DIRECT TENSION INDICATOR WASHERS IN ACCORDANCE WITH THE STANDARD SPECIFICATIONS.

TENSION ON THE ASTM A449 BOLTS THROUGH THE GIRDER WEB SHALL BE SNUG TIGHTENED FOLLOWED BY AN ADDITIONAL 1/4 TURN.

THE PLATES, BENT PLATES, AND ANGLES SHALL BE GALVANIZED OR METALLIZED IN ACCORDANCE WITH THE STANDARD SPECIFICATIONS. FOR THERMAL SPRAYED COATINGS (METALLIZATION), SEE SPECIAL PROVISIONS.

FOR METALLIZATION, APPLY A THERMAL SPRAYED COATING WITH A SEAL COAT TO ALL STEEL DIAPHRAGM SURFACES IN ACCORDANCE WITH THE DEPARTMENT'S THERMAL SPRAYED COATINGS (METALLIZATION) PROGRAM, THERMAL SPRAYED COATINGS SPECIAL PROVISION AND SECTION 442 OF THE STANDARD SPECIFICATIONS.

GALVANIZE THE HIGH STRENGTH BOLTS, NUTS, WASHERS AND DIRECT TENSION INDICATORS IN ACCORDANCE WITH THE STANDARD SPECIFICATIONS.

USE AN ASTM F436 HARDENED WASHER WITH STANDARD AND SLOTTED HOLES UNDER EACH BOLT HEAD AND NUT.

FOR BOLTS THROUGH THE GIRDER WEB, PROVIDE SUFFICIENT LENGTH OF THREADS ON ALL BOLTS TO ACCOMMODATE WASHERS AND THE THICKNESS OF CONNECTING MEMBER PLUS AT LEAST 1/4" PROJECTION BEYOND THE NUT.

INTERMEDIATE DIAPHRAGM ASSEMBLY SHALL COMPLY WITH SECTION 1072 OF THE STANDARD SPECIFICATIONS.

SUBMIT TWO SETS OF WORKING DRAWINGS FOR THE INTERMEDIATE DIAPHRAGM ASSEMBLY FOR REVIEW, COMMENTS AND ACCEPTANCE. AFTER REVIEW, COMMENTS, AND ACCEPTANCE, SUBMIT SEVEN SETS FOR DISTRIBUTION.

IN THE EXTERIOR BAYS, PLACE TEMPORARY STRUTS BETWEEN PRESTRESSED GIRDERS ADJACENT TO THE STEEL DIAPHRAGMS. STRUTS SHALL REMAIN IN PLACE 3 DAYS AFTER CONCRETE IS PLACED.

THE COST OF THE STEEL DIAPHRAGMS AND ASSEMBLIES SHALL BE INCLUDED IN THE UNIT PRICE BID FOR PRESTRESSED CONCRETE GIRDERS.

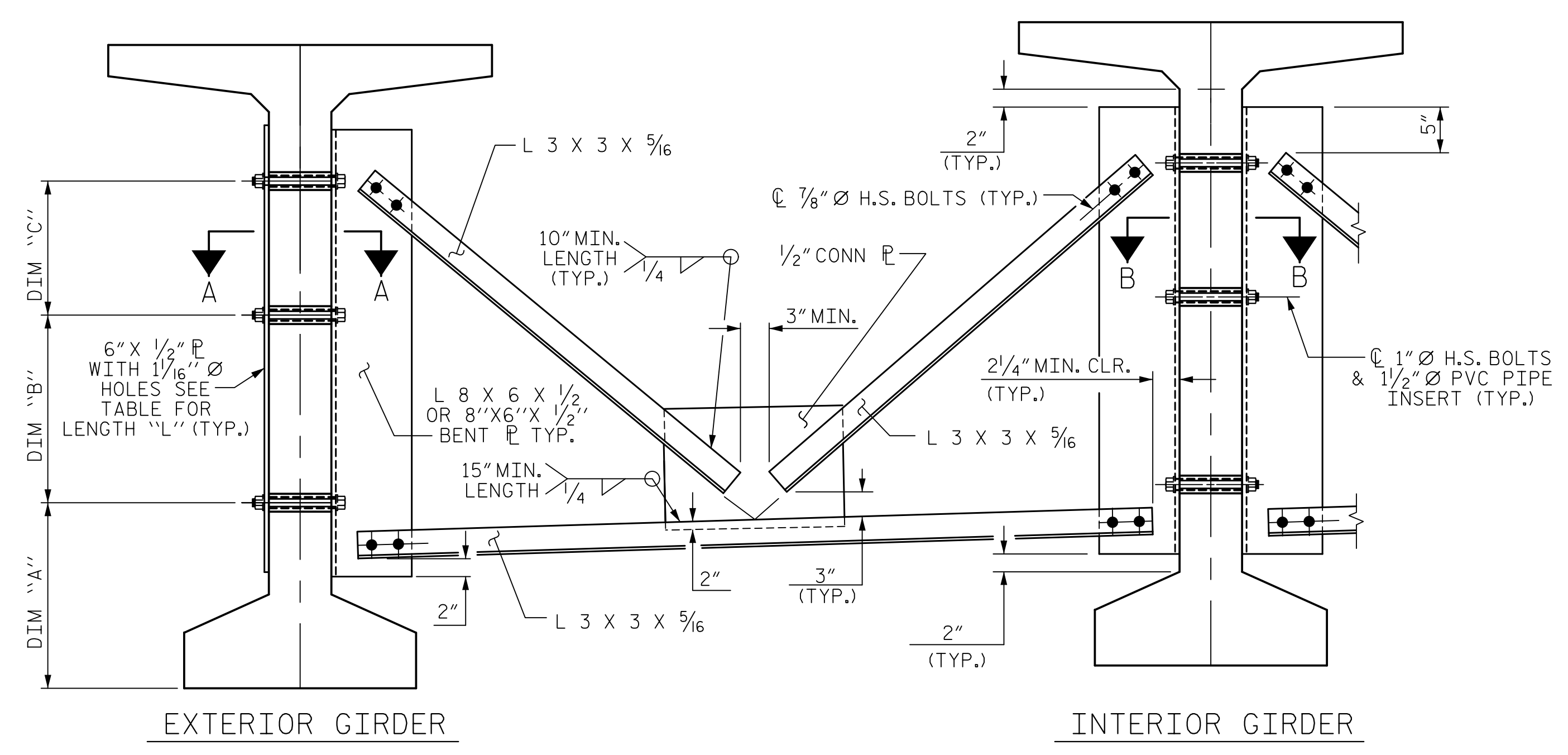

PART SECTION AT INTERMEDIATE DIAPHRAGM
(72" BULB TEE GIRDER SHOWN)

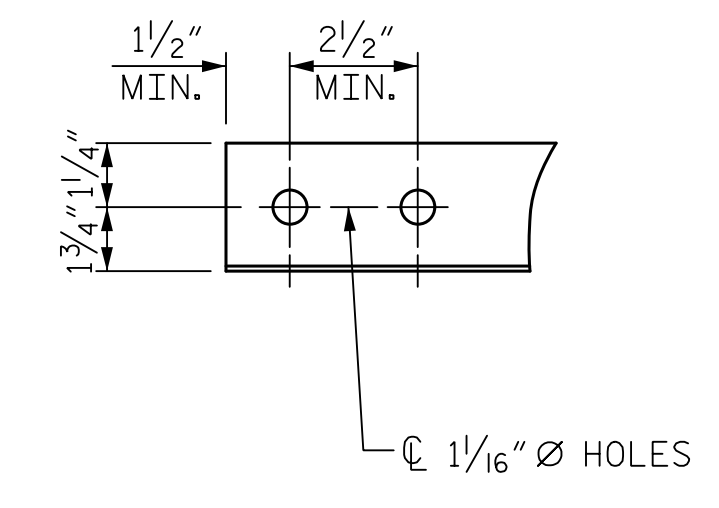
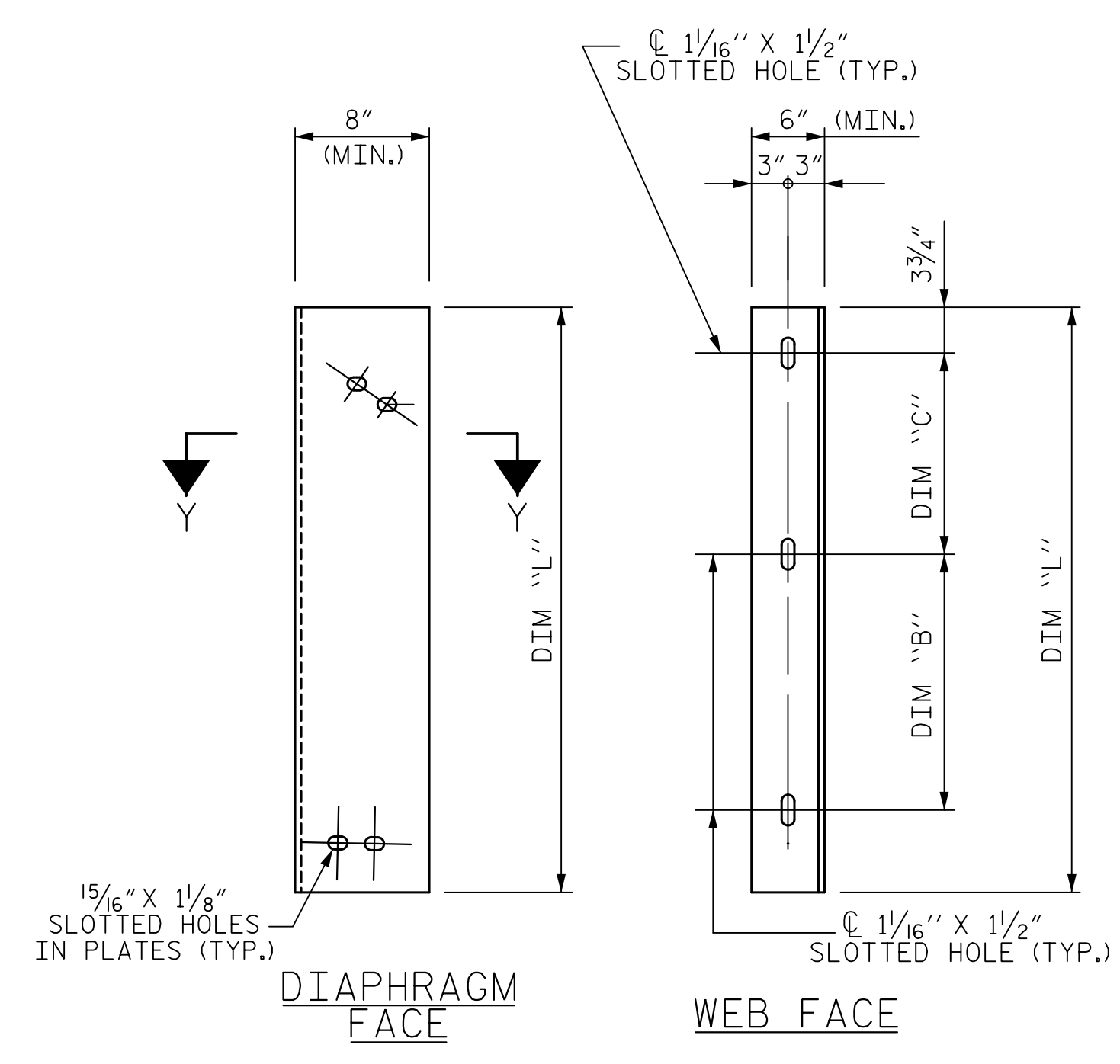

ANGLE END
(L 3 X 3 X 5/16)

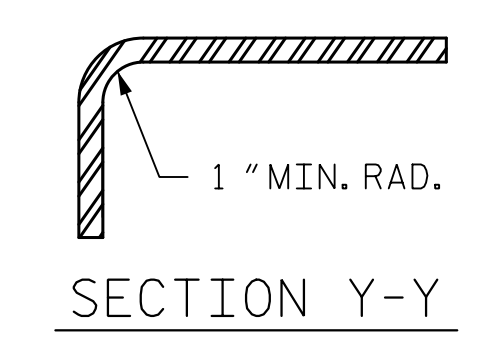

CONNECTOR PLATE DETAIL

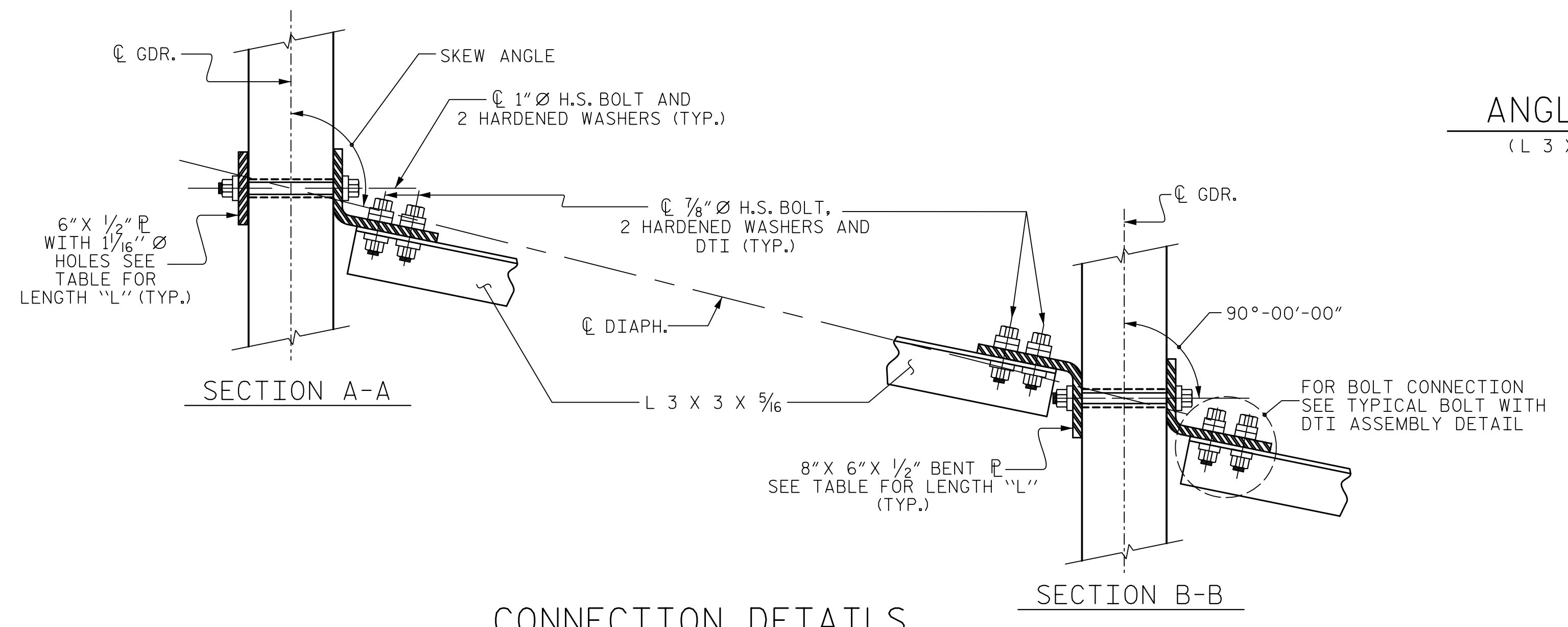

CONNECTION DETAILS

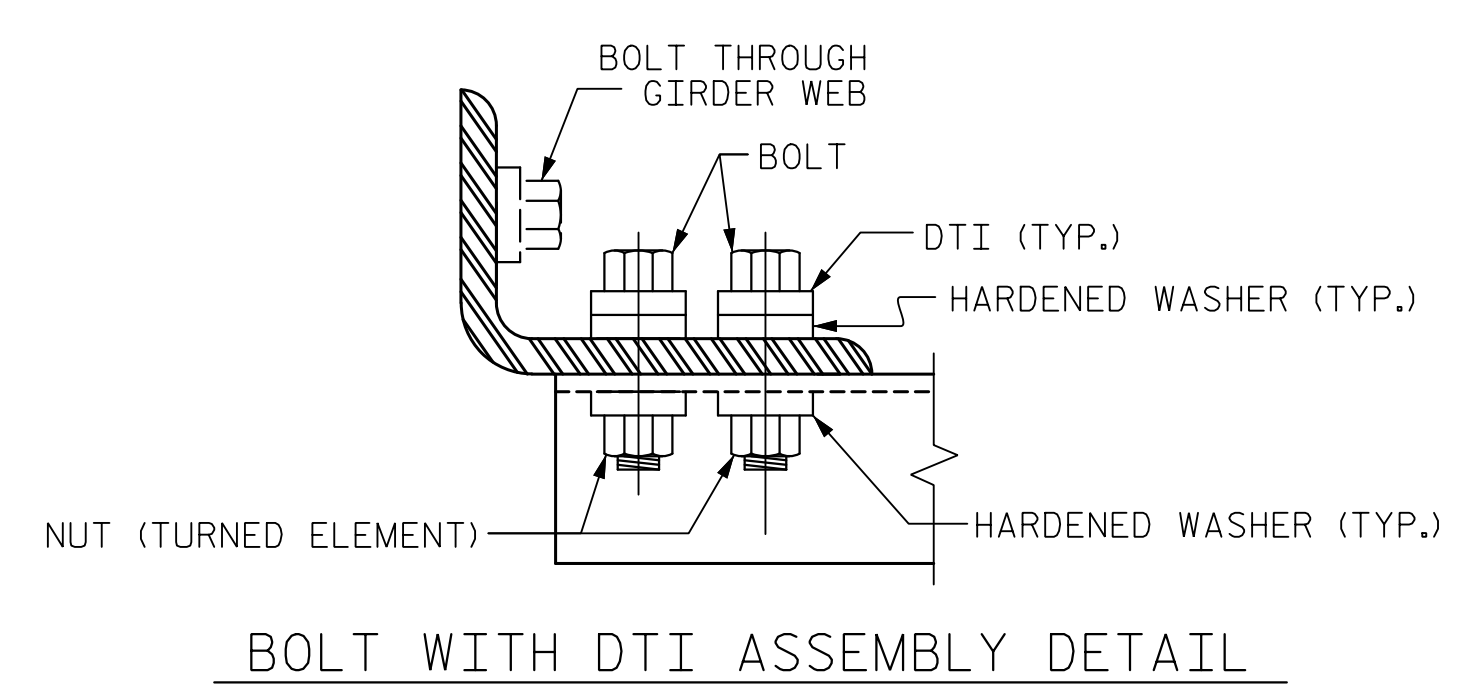

BOLT WITH DTI ASSEMBLY DETAIL

TABLE

GIRDER TYPE	DIM "A"	DIM "B"	DIM "C"	DIM "L"
72" BULB TEE	1'-4 1/4"	1'-9 1/4"	1'-9 1/4"	4'-2"

PROJECT NO. R-5021
BRUNSWICK COUNTY
 STATION: 39+52.37 -Y14A-

SHEET 3 OF 3

STATE OF NORTH CAROLINA
 DEPARTMENT OF TRANSPORTATION
 RALEIGH

STANDARD
 INTERMEDIATE
 STEEL DIAPHRAGMS
 FOR 72"
 MODIFIED BULB TEE
 PRESTRESSED CONCRETE
 GIRDERS

DocuSigned by:
 R. Bruce Bosley
 SEAL 046234
 ENGINEER
 12/7/2018

DocuSigned by:
 Paul J. Barber
 SEAL 12916
 ENGINEER
 12/7/2018

DOCUMENT NOT CONSIDERED
 FINAL UNLESS ALL
 SIGNATURES COMPLETED

HNTB HNTB NORTH CAROLINA, P.C.
 NC License No. C-1554
 343 E. Six Forks Rd., Suite 200, Raleigh, N.C. 27609

DRAWN BY: L. WATERS DATE: 7/18
 CHECKED BY: B. BOSLEY DATE: 7/18
 DESIGN ENGINEER OF RECORD: B. BOSLEY DATE: 12/18

DWG. NO. II

REVISIONS					SHEET NO.
NO.	BY	DATE	NO.	BY	DATE
1			3		
2			4		

TOTAL SHEETS: 24

ASSEMBLED BY: LLW DATE: 3/18
 CHECKED BY: RBB DATE: 3/18

DRAWN BY: RWW 11/09
 CHECKED BY: GM 11/09

ADDED 11/23/09R
 REV. 10/11/11 MAA/GM