

03-0215 /CCTV-7
 NC 211 (HOWE ST) AT
 NC 87 (RIVER RD)
 SR 1852 (ROBERT RUARK DR)

COLOR CODE TIA/EIA 598-C		LEGEND	
(1) BLUE	(7) RED	X = NEW FUSION SPLICE INDIVIDUAL FIBER	
(2) ORANGE	(8) BLACK	● = EXISTING FUSION SPLICE	
(3) GREEN	(9) YELLOW	C = CAP AND SEAL	
(4) BROWN	(10) VIOLET	EXPRESS = EXPRESS ENTIRE BUFFER TUBE THROUGH WITHOUT CUTTING	
(5) SLATE	(11) ROSE	BUFFER SPLICE = SPLICE ALL FIBERS IN BUFFER TUBE COLOR TO COLOR	
(6) WHITE	(12) AQUA		

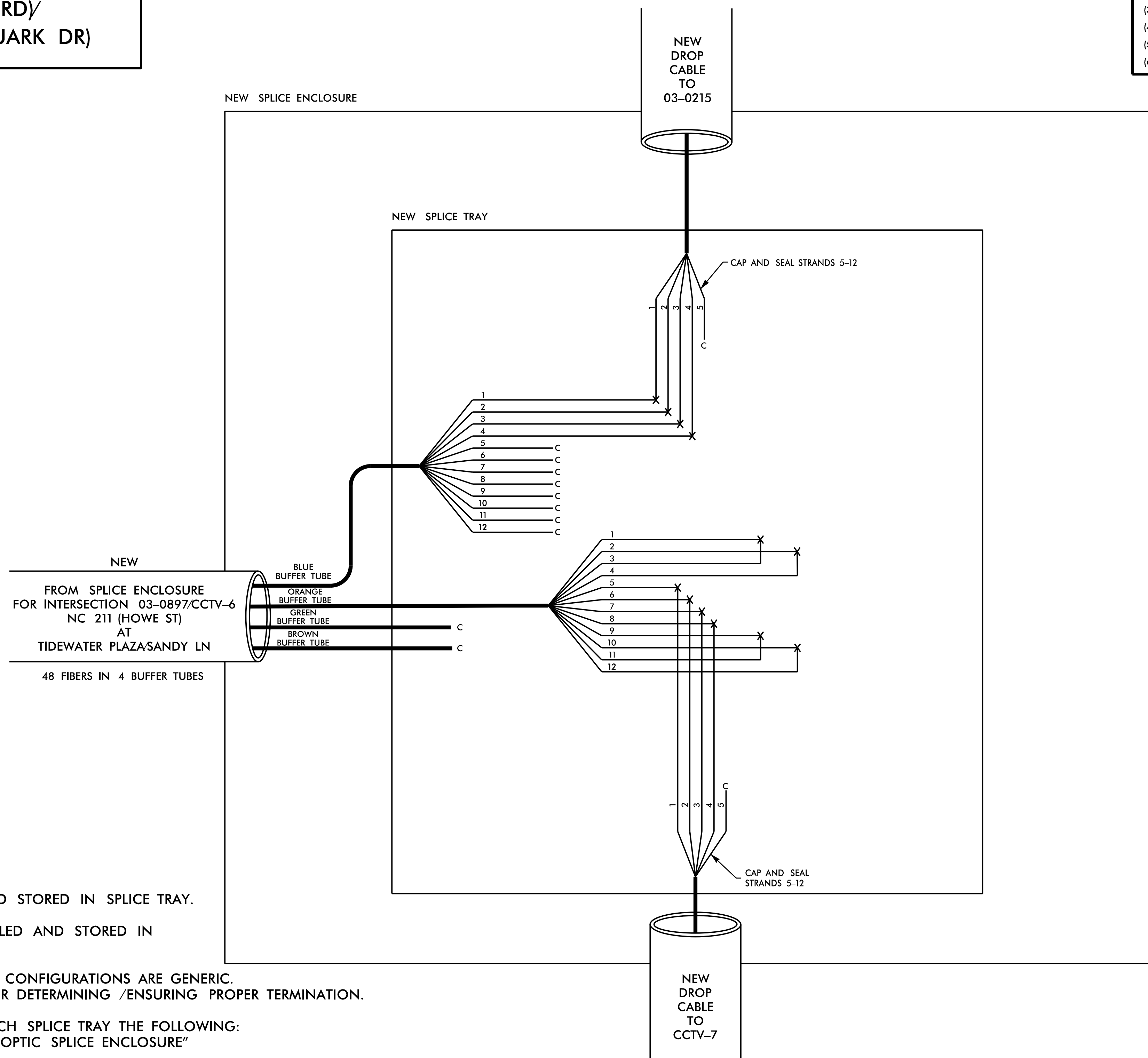

NOTES:

- UNUSED FIBERS LEFT COILED AND STORED IN SPLICE TRAY.
- UNUSED BUFFER TUBES LEFT COILED AND STORED IN SPLICE TRAY.
- ETHERNET SWITCH TERMINATION CONFIGURATIONS ARE GENERIC. CONTRACTOR IS RESPONSIBLE FOR DETERMINING /ENSURING PROPER TERMINATION.
- INCLUDE ON THE COVER OF EACH SPLICE TRAY THE FOLLOWING: REFERENCE SECTION 1731 "FIBER OPTIC SPLICE ENCLASURE"
 - SPLICE
 - DATE
 - COMPANY NAME
 - NAME OF INDIVIDUAL PERFORMING THE SPLICING

PRIOR TO INSTALLING THE COVER ON THE SPLICE TRAY, TAKE A DIGITAL PHOTOGRAPH SHOWING THE SPLICE TRAY AND INFORMATION SHOWN ABOVE (1-4) AND SUBMIT PHOTOGRAPH ALONG WITH OTDR TEST RESULTS.

- SIX (6) WEEKS PRIOR TO BEGINNING WORK ON THE SIGNAL SYSTEM, CONTACT THE DIVISION 3 DEPUTY TRAFFIC ENGINEER, STONEWALL (STONEY) MATHIS, AT 910-341-2200 TO ARRANGE FOR THE DIVISION TO PROGRAM THE NEW FIELD ETHERNET SWITCHES WITH THE NECESSARY NETWORK CONFIGURATION DATA, INCLUDING BUT NOT LIMITED TO THE PROJECT IP ADDRESS, DEFAULT GATEWAY, SUBNET MASK, AND VLAN ID INFORMATION. NOTIFY THE DEPUTY TRAFFIC ENGINEER AFTER ALL WORK IS PERFORMED TO ENSURE THAT ALL FIBER CIRCUITS ARE FUNCTIONING PROPERLY. WORK IS NOT COMPLETE UNTIL THE SIGNAL SYSTEM IS BACK UP AND FUNCTIONAL.

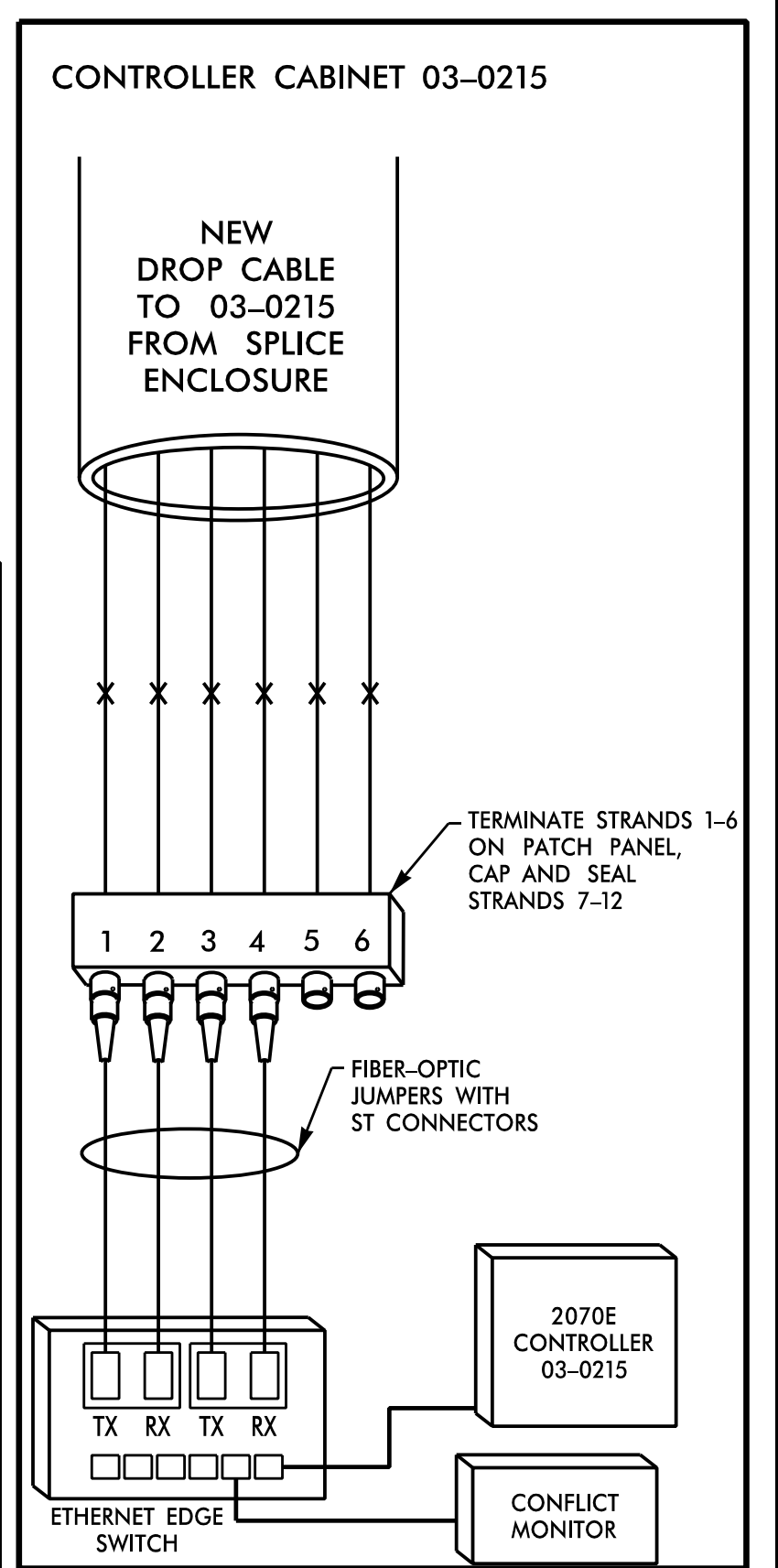
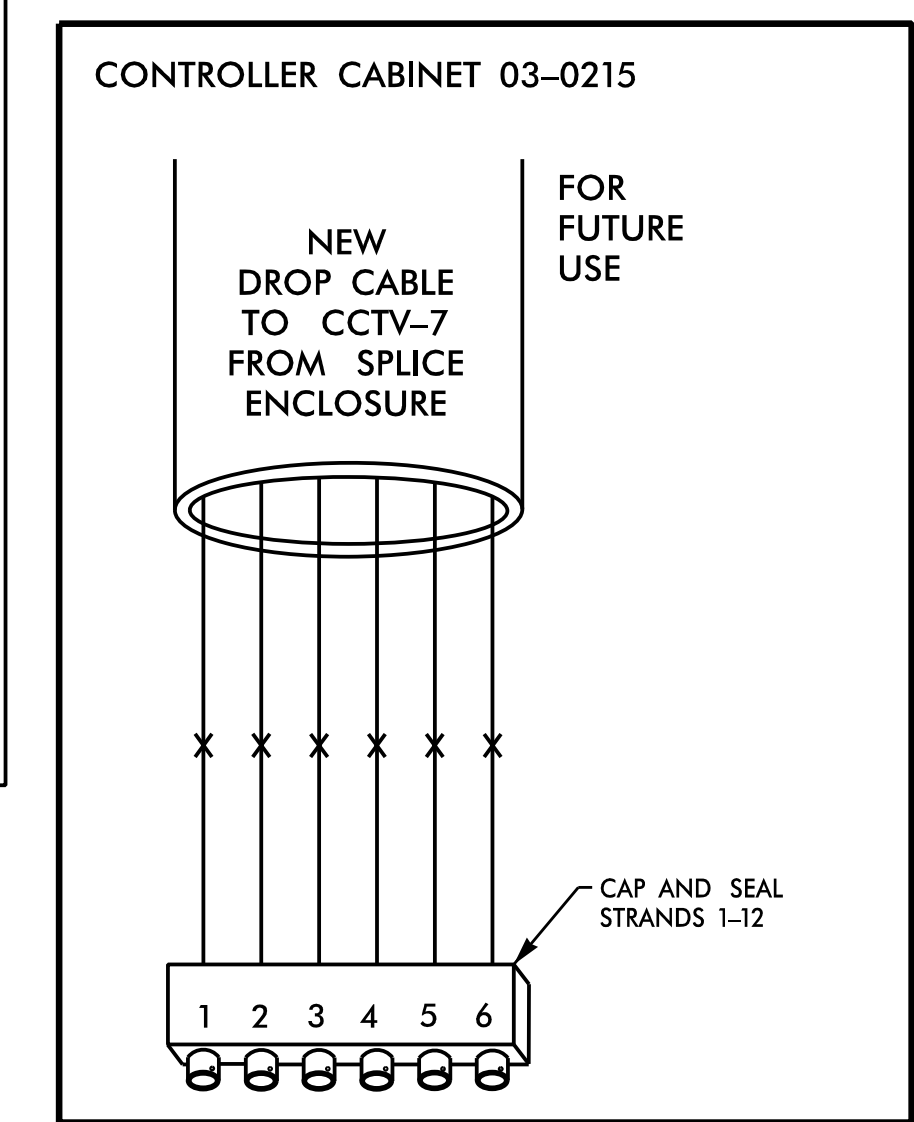

DOCUMENT NOT CONSIDERED FINAL UNLESS ALL SIGNATURES COMPLETED

HNTB HNTB NORTH CAROLINA, P.C.
 343 E. Six Forks Road, Suite 200
 Raleigh, North Carolina 27609
 NC License No: C-1554
 (919) 548-8997

<p>Plans Prepared for:</p> <p>250 N. Greenfield Place, Garner, NC 27529</p>	<p>NC 211 (SOUTHPORT-SUPPLY RD / HOWE ST) SPLICE DETAIL</p>		<p>SEAL</p>							
	<p>Division 3 Brunswick Co. Southport</p> <p>PLAN DATE: June 2018 REVIEWED BY: T.R. Terrell</p> <p>PREPARED BY: Rakesh Nune REVIEWED BY: N.R. Simmons</p>	<p>SCALE</p> <p>NONE</p>		<p>REVISIONS</p> <table border="1"> <thead> <tr> <th>NO.</th> <th>REVISIONS</th> <th>INIT.</th> <th>DATE</th> </tr> </thead> <tbody> <tr> <td> </td> <td> </td> <td> </td> <td> </td> </tr> </tbody> </table>	NO.	REVISIONS	INIT.	DATE		
NO.	REVISIONS	INIT.	DATE							
<p>DocuSigned by: Natasha Simmons 9/9/2021 FE0488F3A045A SIGNATURE DATE</p>			<p>CADD Filename: R5021_scp-58.dgn</p>							