

**CCTV-3**  
**NC 211 (SOUTHPORT-SUPPLY RD) AT**  
**NC 133 (LONG BEACH RD)**

COLOR CODE TIA/EIA 598-C		LEGEND	
(1) BLUE	(7) RED	X = NEW FUSION SPLICE INDIVIDUAL FIBER	
(2) ORANGE	(8) BLACK	● = EXISTING FUSION SPLICE	
(3) GREEN	(9) YELLOW	C = CAP AND SEAL	
(4) BROWN	(10) VIOLET	EXPRESS = EXPRESS ENTIRE BUFFER TUBE THROUGH WITHOUT CUTTING	
(5) SLATE	(11) ROSE	BUFFER SPLICE = SPLICE ALL FIBERS IN BUFFER TUBE COLOR TO COLOR	
(6) WHITE	(12) AQUA		

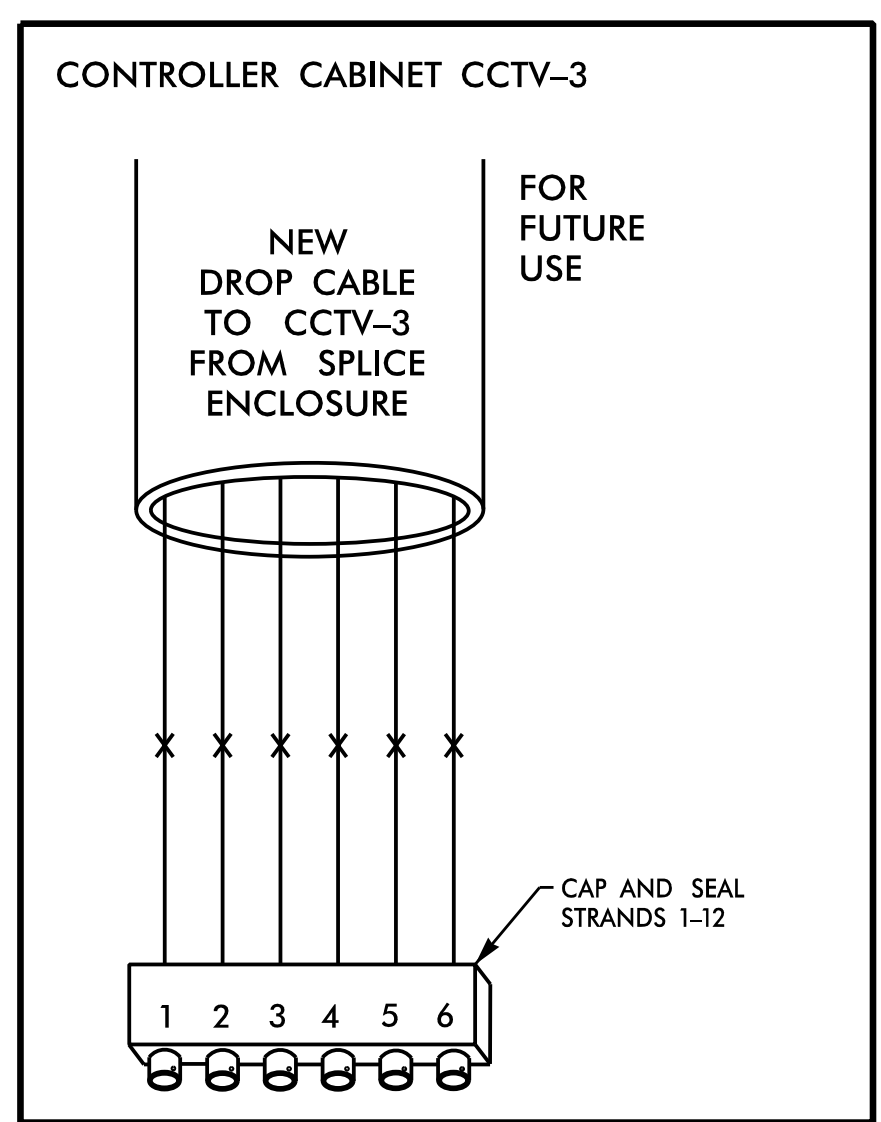
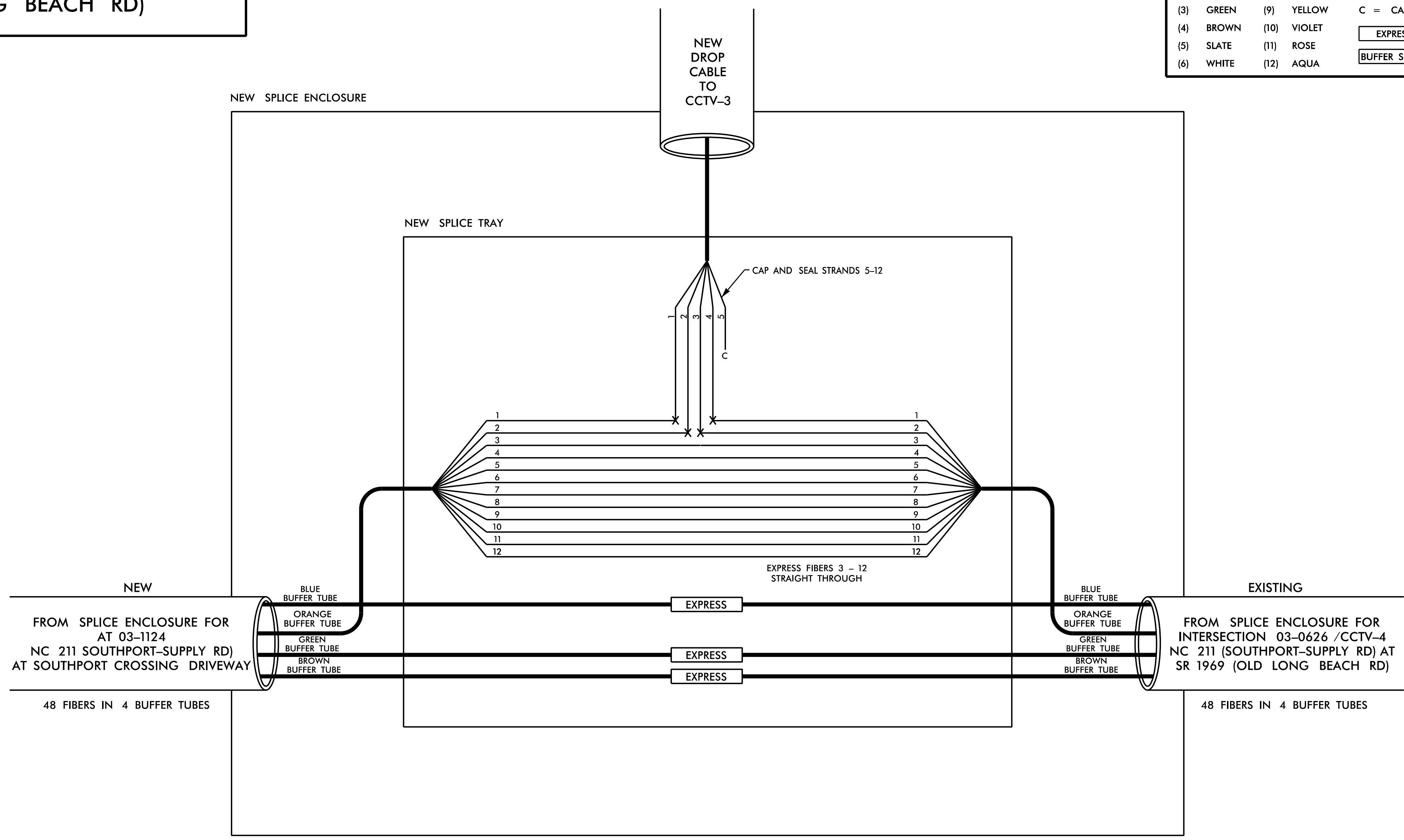

**NOTES:**

- UNUSED FIBERS LEFT COILED AND STORED IN SPLICE TRAY.
- UNUSED BUFFER TUBES LEFT COILED AND STORED IN SPLICE TRAY.
- INCLUDE ON THE COVER OF EACH SPLICE TRAY THE FOLLOWING: REFERENCE SECTION 1731 "FIBER OPTIC SPLICE ENCLOSURE"
  - SPLICE
  - DATE
  - COMPANY NAME
  - NAME OF INDIVIDUAL PERFORMING THE SPLICING

PRIOR TO INSTALLING THE COVER ON THE SPLICE TRAY, TAKE A DIGITAL PHOTOGRAPH SHOWING THE SPLICE TRAY AND INFORMATION SHOWN ABOVE (1-4) AND SUBMIT PHOTOGRAPH ALONG WITH OTDR TEST RESULTS.

**HNTB** HNTB NORTH CAROLINA, P.C.  
 343 E. Six Forks Road, Suite 200  
 Raleigh, North Carolina 27609  
 NC License No: C-1554  
 (919) 548-8997

Plans Prepared for:  250 N. Greenfield Place, Garner, NC 27529	<b>NC 211</b> (SOUTHPORT-SUPPLY RD / HOWE ST) <b>SPLICE DETAIL</b>		SEAL  SEAL 031464 NATASHA R. SIMMONS ENGINEER
	Division 3 Brunswick Co. Southport PLAN DATE: June 2018 REVIEWED BY: T.R. Terrell PREPARED BY: Rakesh Nune REVIEWED BY: N.R. Simmons	REVISIONS INIT. DATE	