

03-0977 / CCTV-2
NC 211 (SOUTHPORT-SUPPLY RD)
AT
ST. JAMES DR

COLOR CODE TIA/EIA 598-C		LEGEND	
(1) BLUE	(7) RED	X = NEW FUSION SPLICE INDIVIDUAL FIBER	
(2) ORANGE	(8) BLACK	● = EXISTING FUSION SPLICE	
(3) GREEN	(9) YELLOW	C = CAP AND SEAL	
(4) BROWN	(10) VIOLET	EXPRESS = EXPRESS ENTIRE BUFFER TUBE THROUGH WITHOUT CUTTING	
(5) SLATE	(11) ROSE	BUFFER SPLICE = SPLICE ALL FIBERS IN BUFFER TUBE COLOR TO COLOR	
(6) WHITE	(12) AQUA		

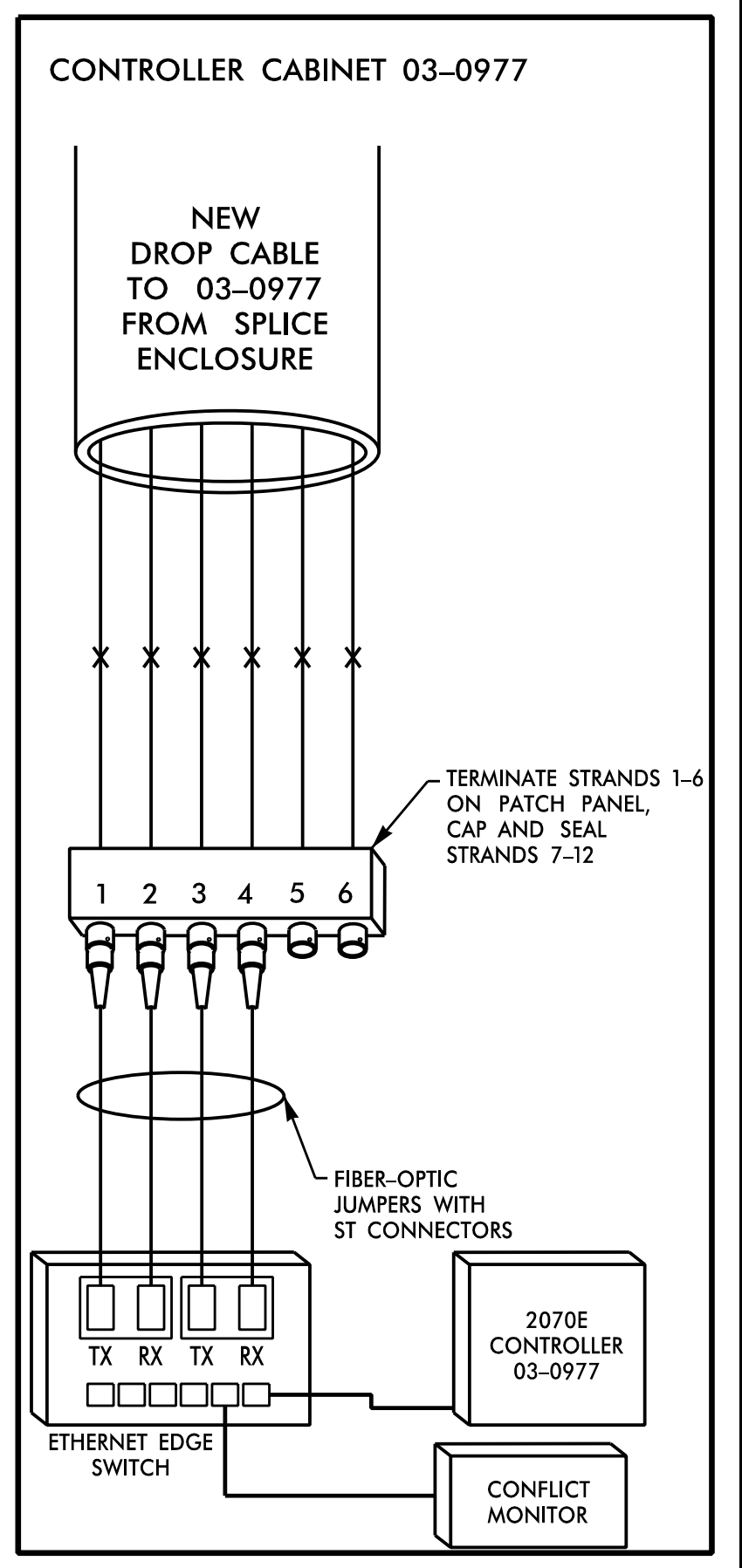
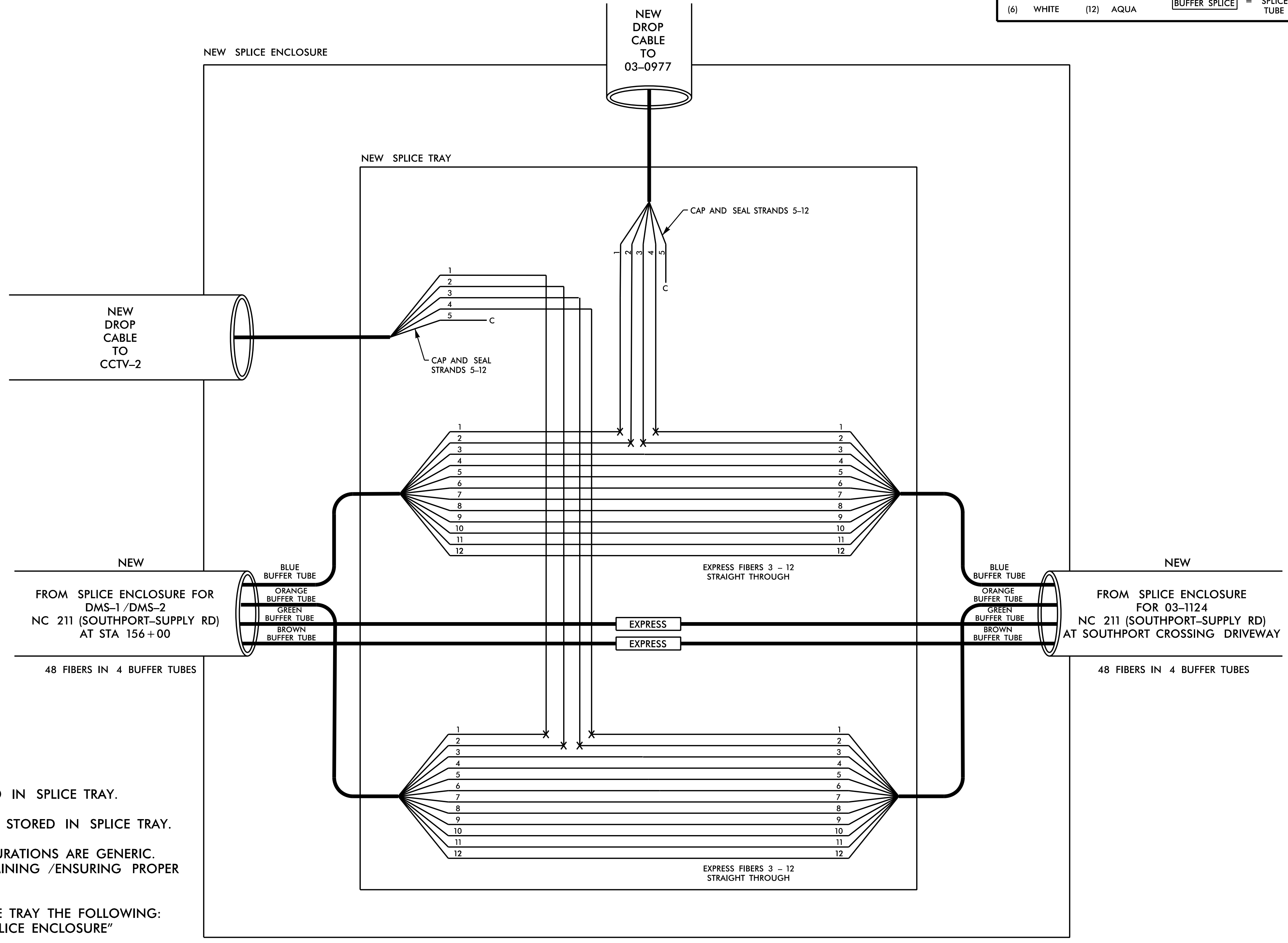
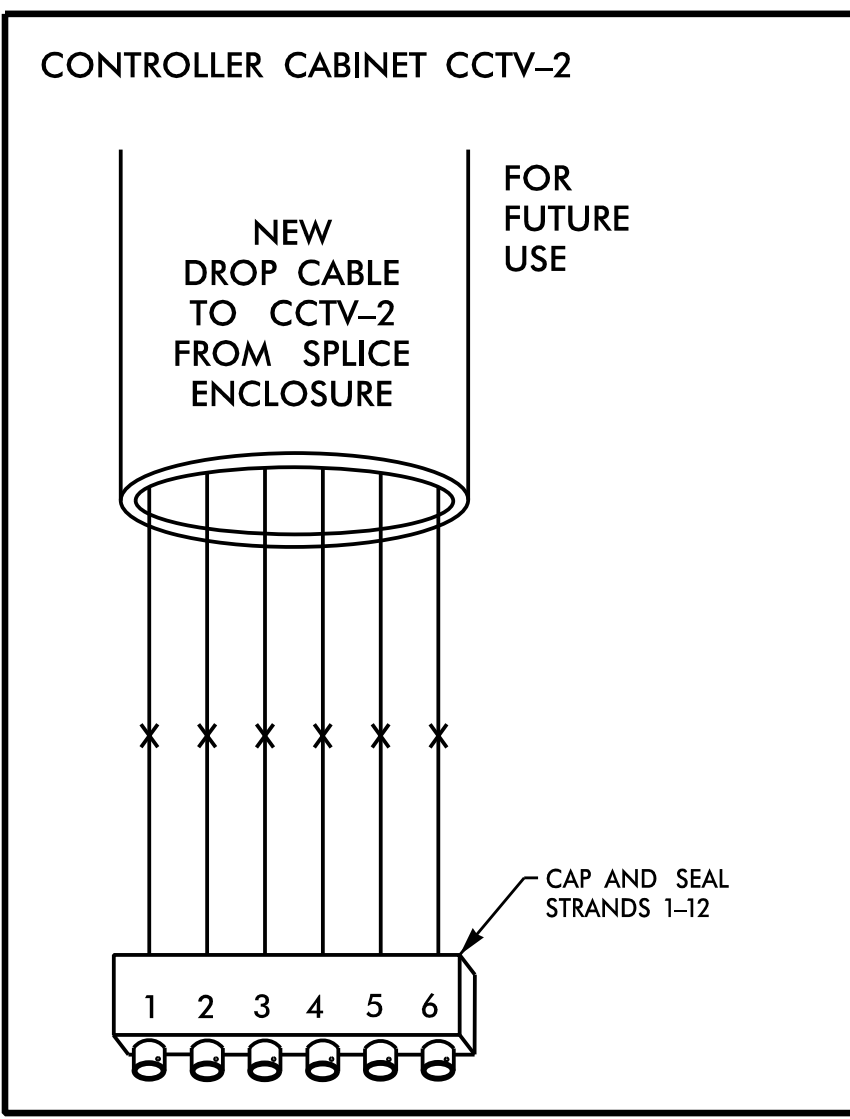

NOTES:

- UNUSED FIBERS LEFT COILED AND STORED IN SPLICE TRAY.
- UNUSED BUFFER TUBES LEFT COILED AND STORED IN SPLICE TRAY.
- ETHERNET SWITCH TERMINATION CONFIGURATIONS ARE GENERIC. CONTRACTOR IS RESPONSIBLE FOR DETERMINING /ENSURING PROPER TERMINATION.
- INCLUDE ON THE COVER OF EACH SPLICE TRAY THE FOLLOWING: REFERENCE SECTION 1731 "FIBER OPTIC SPLICE ENCLOSURE"

- (1) SPLICE
- (2) DATE
- (3) COMPANY NAME
- (4) NAME OF INDIVIDUAL PERFORMING THE SPLICING

PRIOR TO INSTALLING THE COVER ON THE SPLICE TRAY, TAKE A DIGITAL PHOTOGRAPH SHOWING THE SPLICE TRAY AND INFORMATION SHOWN ABOVE (1-4) AND SUBMIT PHOTOGRAPH ALONG WITH OTDR TEST RESULTS.

- SIX (6) WEEKS PRIOR TO BEGINNING WORK ON THE SIGNAL SYSTEM, CONTACT THE DIVISION 3 DEPUTY TRAFFIC ENGINEER, STONEWALL (STONEY) MATHIS, AT 910-341-2200 TO ARRANGE FOR THE DIVISION TO PROGRAM THE NEW FIELD ETHERNET SWITCHES WITH THE NECESSARY NETWORK CONFIGURATION DATA, INCLUDING BUT NOT LIMITED TO THE PROJECT IP ADDRESS, DEFAULT GATEWAY, SUBNET MASK, AND VLAN ID INFORMATION. NOTIFY THE DEPUTY TRAFFIC ENGINEER AFTER ALL WORK IS PERFORMED TO ENSURE THAT ALL FIBER CIRCUITS ARE FUNCTIONING PROPERLY. WORK IS NOT COMPLETE UNTIL THE SIGNAL SYSTEM IS BACK UP AND FUNCTIONAL.

DOCUMENT NOT CONSIDERED FINAL UNLESS ALL SIGNATURES COMPLETED

HNTB HNTB NORTH CAROLINA, P.C.
343 E. Six Forks Road, Suite 200
Raleigh, North Carolina 27609
NC License No: C-1554
(919) 548-8997

Plans Prepared for: 250 N. Greenfield Place, Garner, NC 27529	NC 211 (SOUTHPORT-SUPPLY RD / HOWE ST) SPLICE DETAIL		 SEAL NORTH CAROLINA PROFESSIONAL ENGINEER NATASHA R. SIMMONS
	Division 3 Brunswick Co. Southport	PLAN DATE: June 2018 REVIEWED BY: T.R. Terrell	
SCALE NONE	REVISIONS INIT. DATE	SIGNATURE DATE	DocuSigned by: Natasha Simmons 9/9/2021 FE0488F3AD45A... SIGNATURE DATE CADD Filename: R5021 scp-47.dgn