

SYSTEM #1

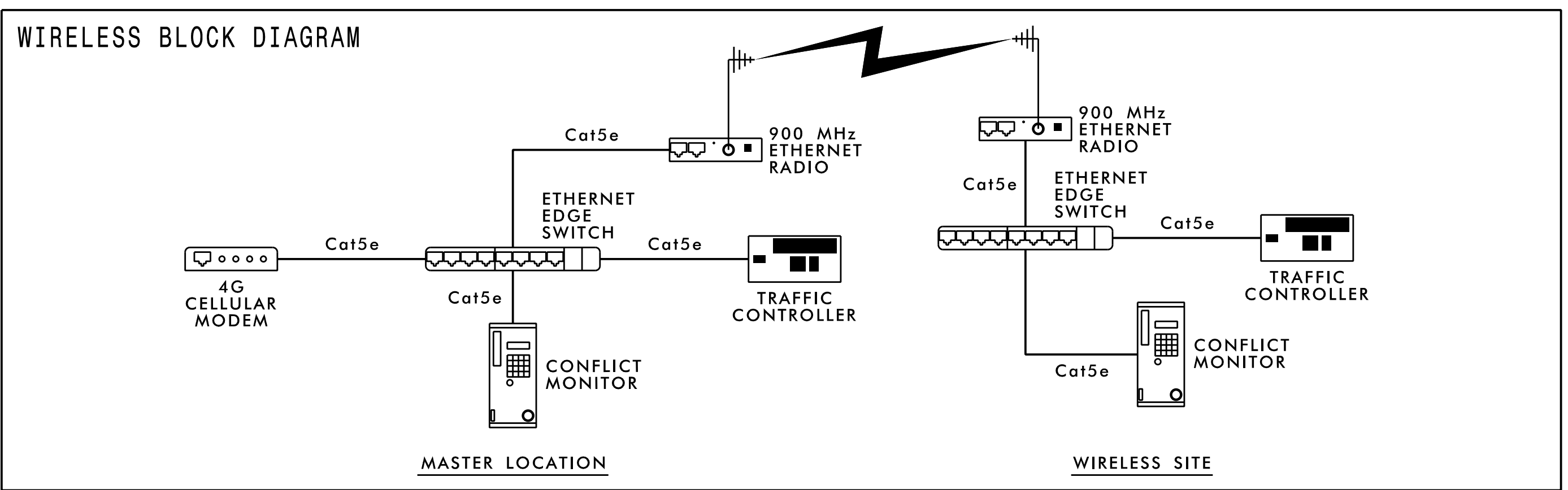
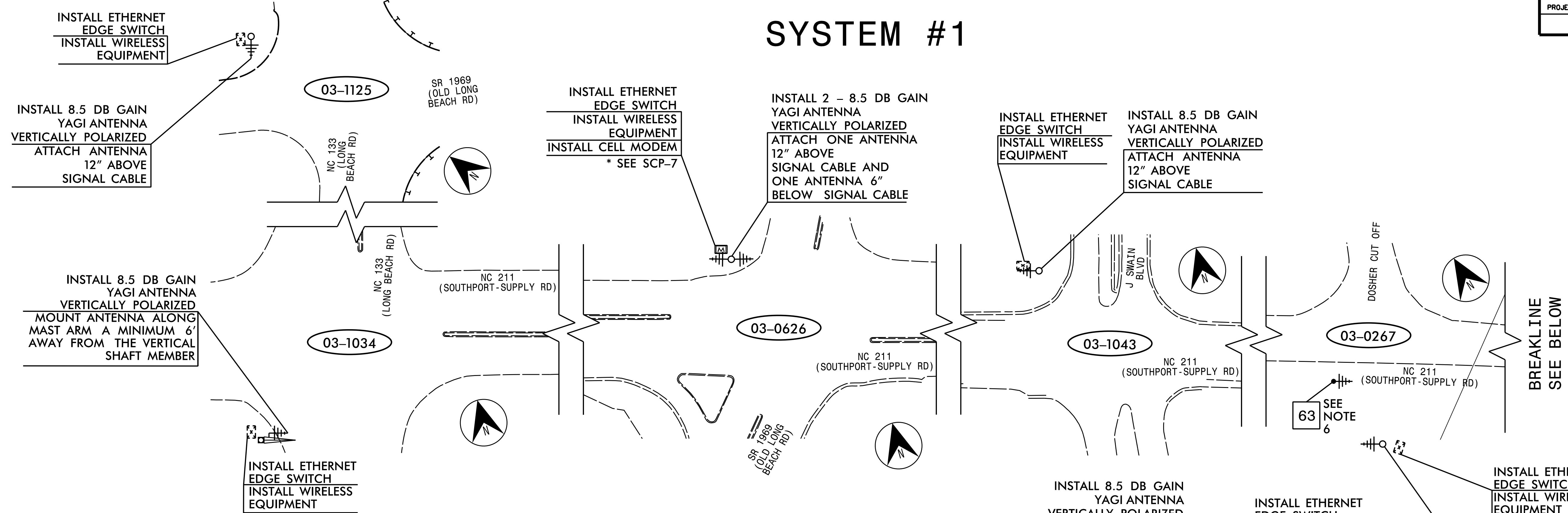

- NOTES FOR EXISTING COMMUNICATIONS CABLE:**
- REMOVE ALL EXISTING COMMUNICATIONS CABLE FROM INSIDE THE CONTROLLER CABINET AND THE RISER ASSEMBLY. LEAVE RISER ASSEMBLY IN PLACE.
- NOTES FOR WIRELESS COMMUNICATIONS:**
- INSTALL COAXIAL CABLE:
 - ON WOOD POLES, REQUIRING A NEW RIGID GALVANIZED STEEL RISER, INSTALL A 2" RISER WITH WEATHERHEAD AND ROUTE THE COAXIAL CABLE TO THE ANTENNA.
 - ON METAL POLES WITH MAST ARMS, RUN COAXIAL CABLE UP THROUGH THE POLE AND OUT THE MAST ARM; FIELD DRILL A 1/2" HOLE UP THROUGH THE BOTTOM OF MAST ARM FOR INSTALLATION OF THE COAXIAL CABLE TO THE ANTENNA.
 - ON METAL STRAIN POLES, RUN COAXIAL CABLE UP THROUGH THE POLE AND OUT THE WEATHERHEAD AND ROUTE THE COAXIAL CABLE TO THE ANTENNA.
 - BETWEEN THE POINT OF EXITING THE RISER, METAL POLE, OR MAST ARM AND THE ANTENNA, SECURE THE COAXIAL CABLE TO THE STRUCTURE USING 3/4" STAINLESS STEEL STRAPS EVERY 12".
 - IF AN EXISTING 2" SPARE RIGID GALVANIZED STEEL RISER IS AVAILABLE, INSTALL THE COAXIAL CABLE IN THE SPARE RISER.
 - INSTALL WIRELESS ANTENNA ON POLE WITH RF WARNING SIGN. (NOTE: RF WARNING SIGN NOT REQUIRED WHEN ANTENNA IS INSTALLED ON AN NCDOT-OWNED POLE.)
 - MAINTAIN PROPER CLEARANCE FROM ALL UTILITIES PER THE NATIONAL ELECTRICAL SAFETY CODE.
 - REFERENCE "WIRELESS RADIO ANTENNA TYPICAL DETAILS" IN THE 2018 NCDOT ROADWAY STANDARD DRAWINGS.
 - RETURN EXISTING WIRELESS RADIO EQUIPMENT TO THE DIVISION 03 SIGNAL SHOP. THE DIVISION 03 OFFICE IS LOCATED AT 5501 BARBADOS BLVD, CASTLE HAYNE, NC 28429 AND CAN BE REACHED AT 910-341-2200.
 - SIX (6) WEEKS PRIOR TO BEGINNING WORK ON THE SIGNAL SYSTEM, CONTACT THE DIVISION 3 DEPUTY TRAFFIC ENGINEER, STONEWALL (STONE) MATHIS, AT 910-341-2200 TO ARRANGE FOR THE DIVISION TO PROGRAM THE NEW FIELD ETHERNET SWITCHES WITH THE NECESSARY NETWORK CONFIGURATION DATA, INCLUDING BUT NOT LIMITED TO: THE PROJECT IP ADDRESS, DEFAULT GATEWAY, SUBNET MASK AND VLAN ID INFORMATION. NOTIFY THE DEPUTY TRAFFIC ENGINEER AFTER ALL WORK IS PERFORMED TO ENSURE THAT ALL FIBER CIRCUITS ARE FUNCTIONING PROPERLY. WORK IS NOT COMPLETE UNTIL THE SIGNAL SYSTEM IS BACK UP AND FUNCTIONAL.
 - NCDOT DIVISION 3 WILL FURNISH AND INSTALL THE CELL MODEM. CONTACT SIX (6) WEEKS PRIOR BEGINNING WORK.

BREAKLINE SEE ABOVE

BREAKLINE SEE BELOW

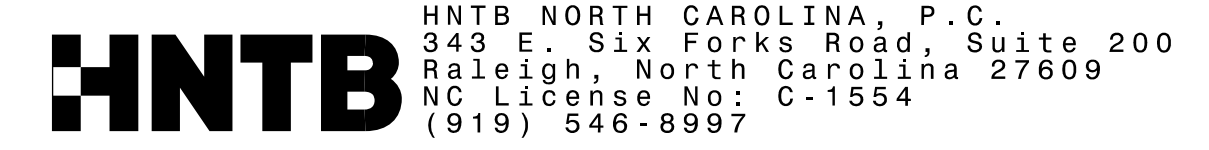
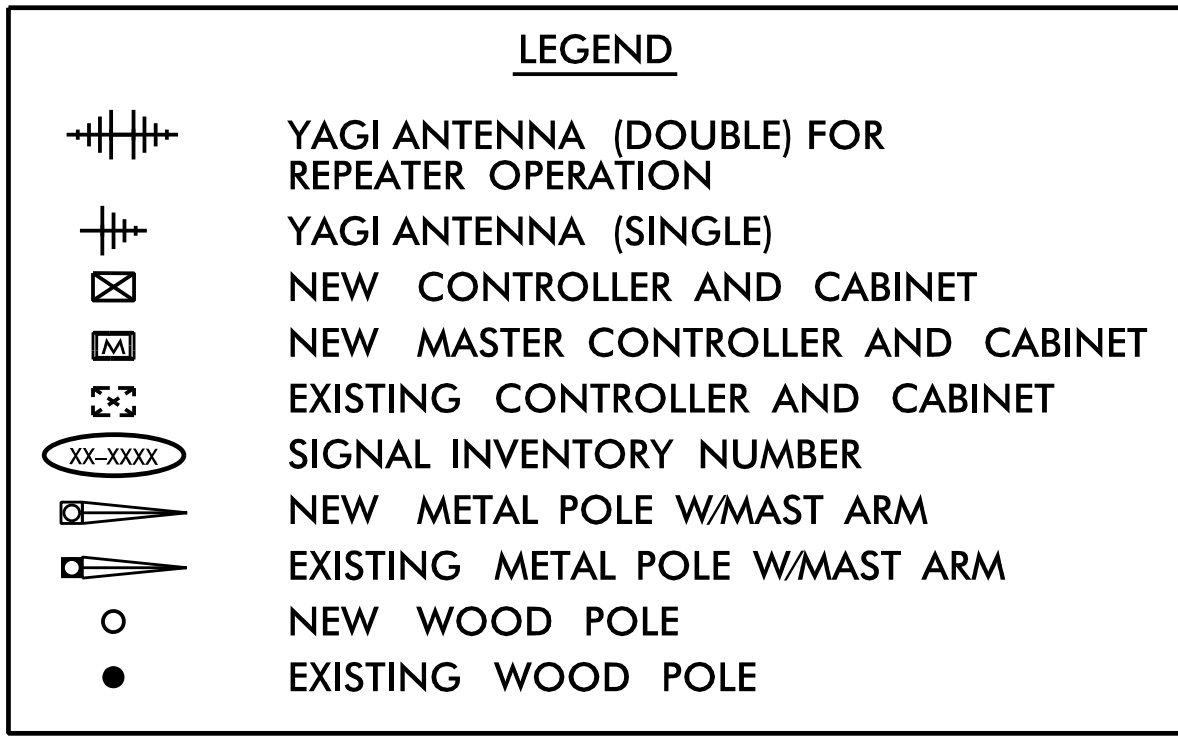

TMP - TEMP 1

DOCUMENT NOT CONSIDERED FINAL UNLESS ALL SIGNATURES COMPLETED

Plans Prepared for: 		NC 211 (SOUTHPORT-SUPPLY RD) CABLE ROUTING PLAN TEMPORARY WIRELESS SYSTEM		SEAL
Division 3 Brunswick Co. Southport		PLAN DATE: June 2017 REVIEWED BY: T.R. Terrell		DocuSigned by: Natasha Simmons 9/9/2017 SEAL ENGINEER NATASHA R. SIMMONS
PREPARED BY: N.K. Vlanich		REVIEWED BY: N.R. Simmons		
REVISIONS		INIT. DATE		SIGNATURE DATE
CADD File name: R5021 scp-04.dgn		SCALE: 0 50 1"=50'		