

DEFAULT PHASING DIAGRAM

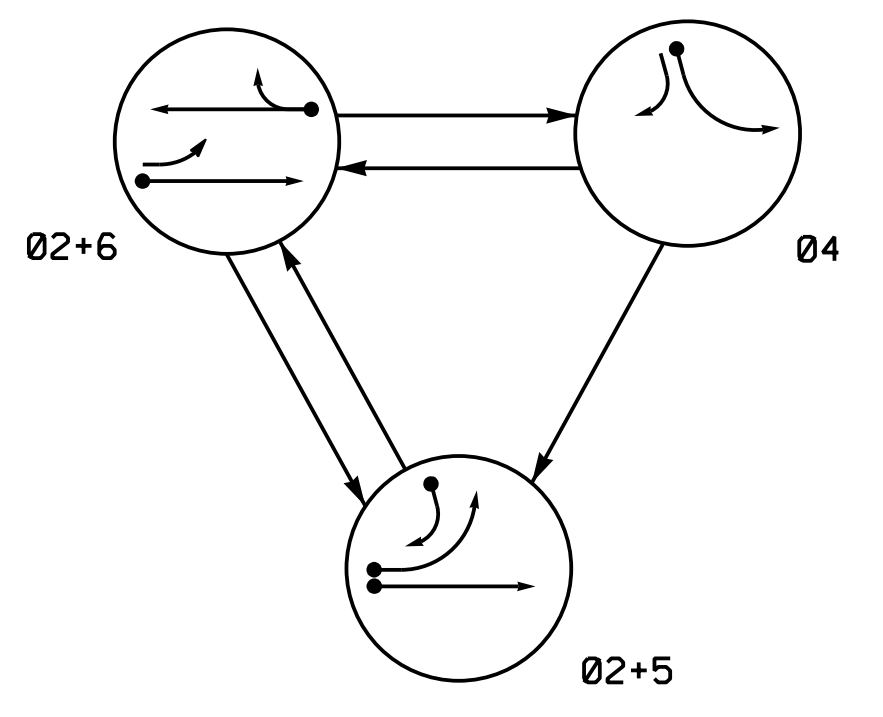

ALTERNATE PHASING DIAGRAM

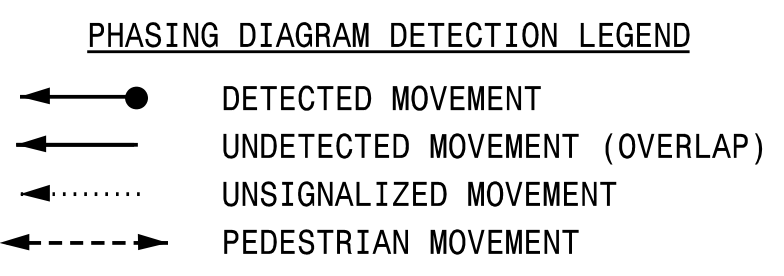
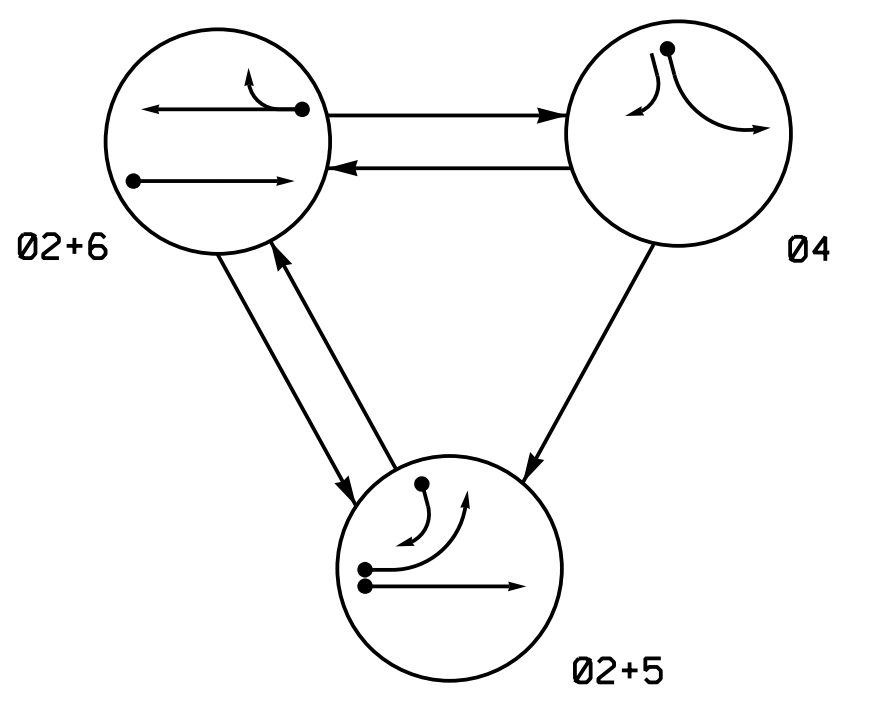

DEFAULT PHASING TABLE OF OPERATION

SIGNAL FACE	PHASE			
	02+5	02+6	04	F I C O B F
21,22	G	G	R	Y
41,42	R	R	G	R
43	E	R	E	R
51	—	—	—	—
61,62	R	G	R	Y

ALTERNATE PHASING TABLE OF OPERATION

SIGNAL FACE	PHASE			
	02+5	02+6	04	F I C O B F
21,22	G	G	R	Y
41,42	R	R	G	R
43	E	R	E	R
51	—	—	—	—
61,62	R	G	R	Y

OASIS 2070 LOOP & DETECTOR INSTALLATION CHART

LOOP	SIZE (FT)	DISTANCE FROM STOPBAR (FT)	TURNS	NEW LOOP	DETECTOR PROGRAMMING				SYSTEM LOOP	NEW CARD
					PHASE	CALLING	EXTENSION	FULL TIME DELAY		
2A	6X6	300	*	*	2	Y	Y	-	-	-
4A	6X40	0	*	*	4	Y	Y	-	-	3
5A	6X40	0	*	*	5	Y	Y	-	-	***15
5B	6X40	0	*	*	**2	Y	Y	-	-	3
6A	6X6	300	*	*	6	Y	Y	-	-	-

* Multizone Microwave Detection.
 ** Disable phase 2 call for 5A during alternate phasing operation.
 *** Reduce delay to 3 seconds during alternate phasing operation.

SIGNAL FACE I.D.

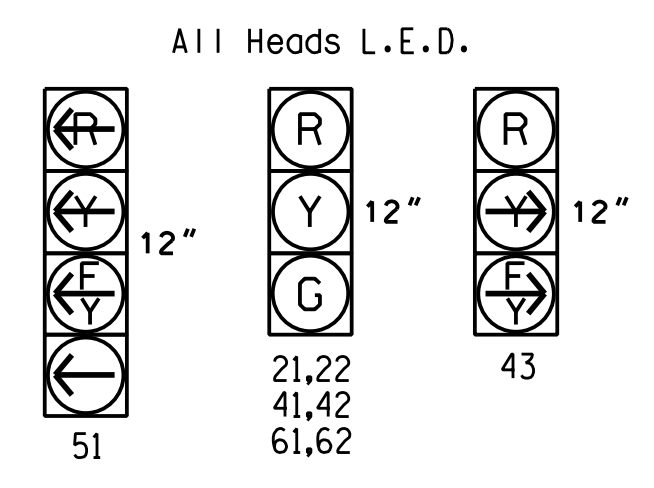

3 Phase Fully Actuated (NC 133 Closed Loop System)

NOTES

- Refer to "Roadway Standard Drawings NCDOT" dated January 2018 and "Standard Specifications for Roads and Structures" dated January 2018.
- Do not program signal for late night flashing operation unless otherwise directed by the Engineer.
- Phase 5 may be lagged.
- Reposition existing signal heads numbered 21,22,51,61 and 62.
- Set all detector units to presence mode.
- Incorporate Microwave Detection system for vehicle detection.
- Provide the Engineer with the Manufacturer's approved Microwave Detection locations and mounting heights to obtain detection zones as shown.
- Maximum times shown in timing chart are for free-run operation only. Coordinated signal system timing values supersede these values.
- Closed loop system data: Controller Asset #: 0267.

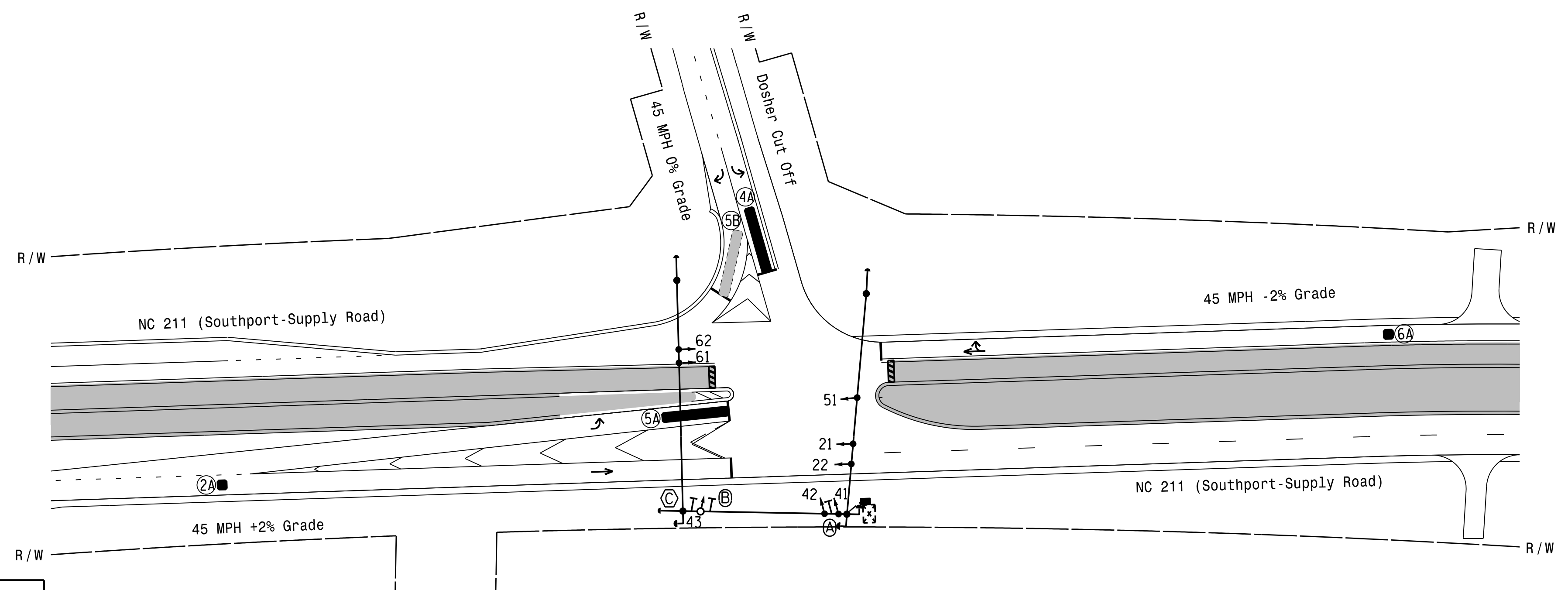

OASIS 2070 TIMING CHART

FEATURE	PHASE			
	2	4	5	6
Min Green 1 *	12	7	7	12
Extension 1 *	6.0	2.0	2.0	6.0
Max Green 1 *	90	30	20	90
Yellow Clearance	4.7	3.0	3.0	4.7
Red Clearance	1.6	3.4	2.3	1.6
Red Revert	2.0	2.0	2.0	2.0
Walk 1 *	-	-	-	-
Don't Walk 1	-	-	-	-
Seconds Per Actuation *	2.5	-	-	2.5
Max Variable Initial *	34	-	-	34
Time Before Reduction *	20	-	-	20
Time To Reduce *	30	-	-	30
Minimum Gap	3.0	-	-	3.0
Recall Mode	MIN RECALL	-	-	MIN RECALL
Vehicle Call Memory	YELLOW	-	-	YELLOW
Dual Entry	-	-	-	-
Simultaneous Gap	ON	ON	ON	ON

* These values may be field adjusted. Do not adjust Min Green and Extension times for phases 2 and 6 lower than what is shown. Min Green for all other phases should not be lower than 4 seconds.

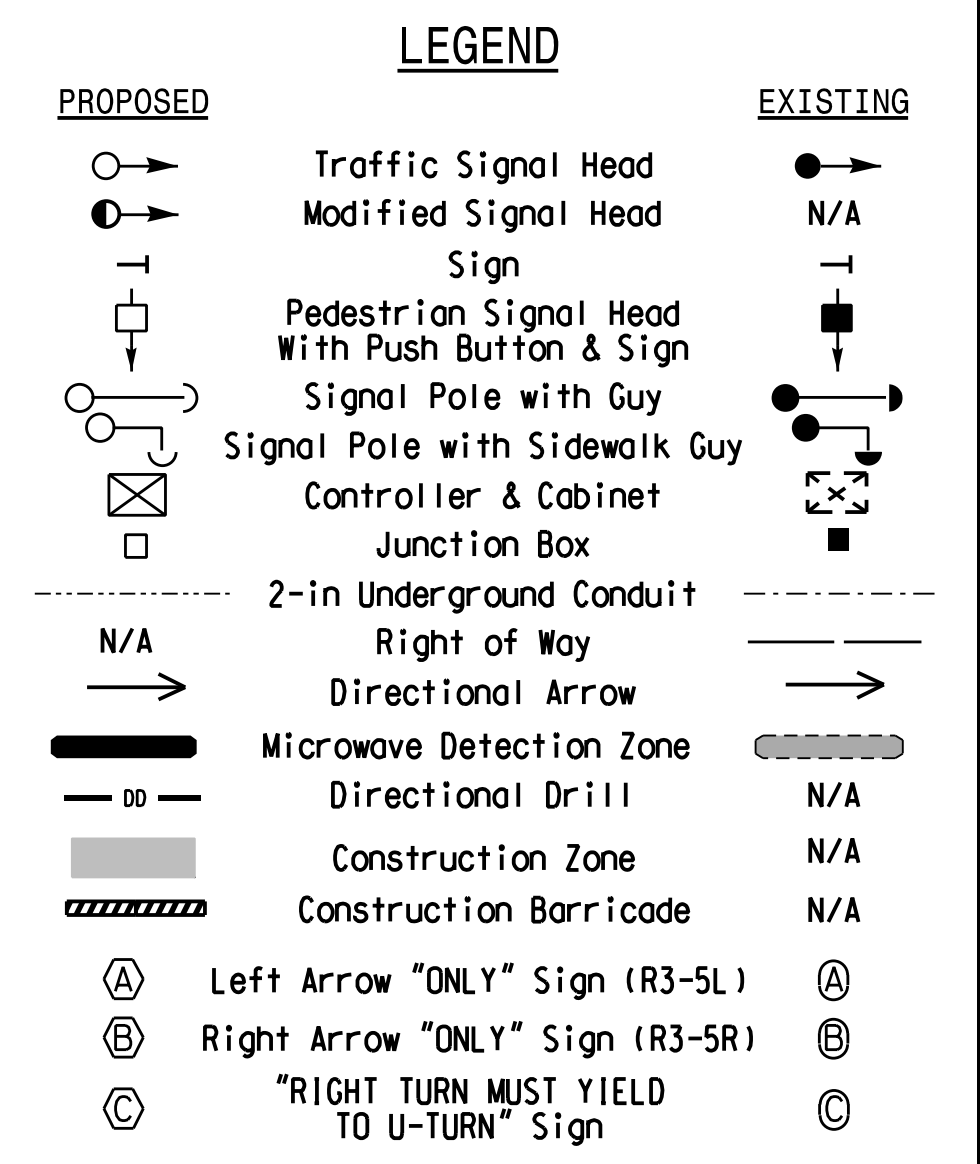

Signal Upgrade
 Temporary Design 4
 Construction Phase 3

DOCUMENT NOT CONSIDERED FINAL UNLESS ALL SIGNATURES COMPLETED

	NC 211 (Southport-Supply Road) at Doshier Cut Off		SEAL
	Division 03 Brunswick Co. Southport PLAN DATE: June 2017 REVIEWED BY: A.D. Klinksiek PREPARED BY: A.H. Thornburg REVIEWED BY: N.R. Simmons	REVISIONS INIT. DATE SIGNATURE DATE 9/10/2021 DATE	

HNTB HNTB NORTH CAROLINA, P.C.
 343 E. Six Forks Road, Suite 200
 Raleigh, North Carolina 27609
 NC License No: C-1554
 (919) 546-8997

