

EDI MODEL 2018ECL-NC CONFLICT MONITOR PROGRAMMING DETAIL

(remove jumpers and set switches as shown)

REMOVE DIODE JUMPERS 2-5, 2-6, 2-9, 2-11, 2-12, 4-8, 4-12, 5-9, 5-11, 5-12, 6-9, 6-11, 8-12, 9-11, 9-12, and 11-12.

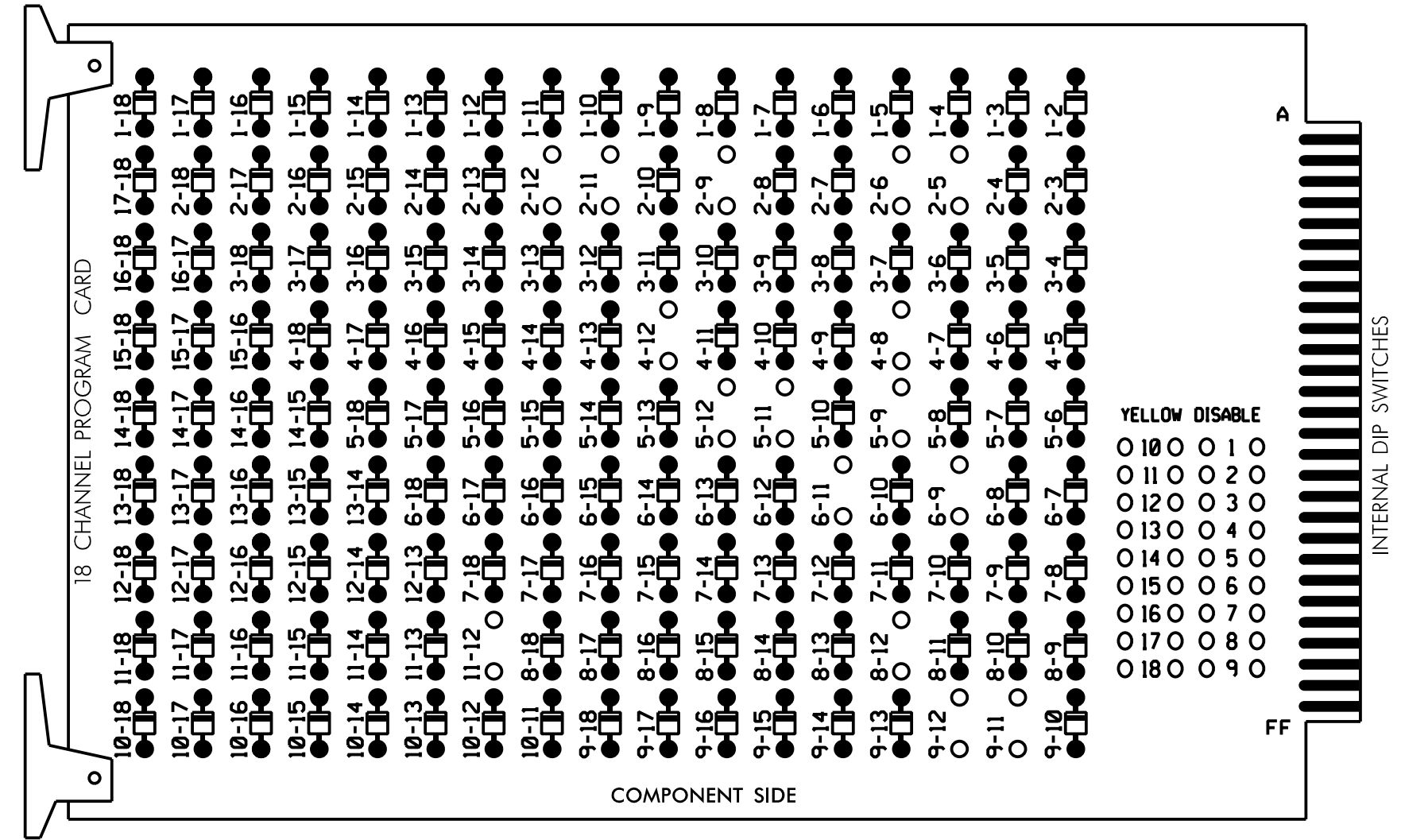

REMOVE JUMPERS AS SHOWN

NOTES:

- Card is provided with all diode jumpers in place. Removal of any jumper allows its channels to run concurrently.
- Ensure jumpers SEL2-SEL5 and SEL9 are present on the monitor board.
- Ensure that Red Enable is active at all times during normal operation.
- Connect serial cable from conflict monitor to comm. port 1 of 2070 controller. Ensure conflict monitor communicates with 2070.

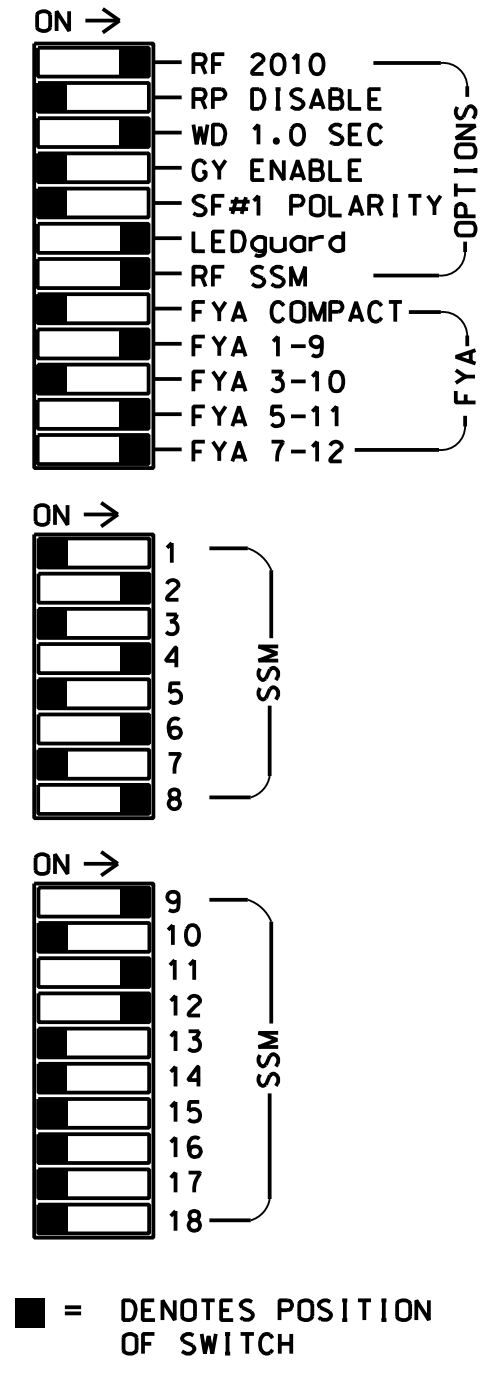

NOTES

- To prevent "flash-conflict" problems, insert red flash program blocks for all unused vehicle load switches in the output file. The installer shall verify that signal heads flash in accordance with the Signal Plans.
- Program phases 4 and 8 for Dual Entry.
- Enable Simultaneous Gap-Out for all Phases.
- Program phases 2 and 6 for Variable Initial and Gap Reduction.
- Program phases 2 and 6 for Startup In Green.
- Program phases 2 and 6 for Yellow Flash, and overlap 1 as Wag Overlaps.
- If this signal will be managed by an ATMS software, enable controller and detector logging for all detectors used at this location.
- The cabinet and controller are part of the NC 133 Closed Loop System.

EQUIPMENT INFORMATION

CONTROLLER.....2070E
 CABINET.....332 W/AUX
 SOFTWARE.....ECONOLITE OASIS
 CABINET MOUNT.....BASE
 OUTPUT FILE POSITIONS...18 WITH AUX. OUTPUT FILE
 LOAD SWITCHES USED.....S2,S5,S7,S8,S11,AUX S1,
 AUX S4,AUX S5
 PHASES USED.....2,4,5,6,8
 OVERLAP "A".....2
 OVERLAP "B".....NOT USED
 OVERLAP "C".....5+6
 OVERLAP "D".....4+5

SIGNAL HEAD HOOK-UP CHART

LOAD SWITCH NO.	S1	S2	S3	S4	S5	S6	S7	S8	S9	S10	S11	S12	AUX S1	AUX S2	AUX S3	AUX S4	AUX S5	AUX S6				
CHU CHANNEL NO.	1	2	13	3	4	14	5	6	15	7	8	16	9	10	17	11	12	18				
PHASE	1	2	2 PED	3	4	4 PED	5	6	6 PED	7	8	8 PED	OLA	OLB	SPARE	OLC	OLD	SPARE				
SIGNAL HEAD NO.	NU	21,22	NU	NU	41,42	NU	51	62,63	NU	NU	81,82	NU	61	NU	NU	51	43	NU				
RED		128			101			134			107							A101				
YELLOW		129			102		*	135			108											
GREEN		130			103			136			109											
RED ARROW																		A121	A114			
YELLOW ARROW																			A122	A115	A102	
FLASHING YELLOW ARROW																			A123		A116	A103
GREEN ARROW								133														

NU = Not Used
 * Denotes install load resistor. See load resistor installation detail this sheet.
 * See pictorial of head wiring in detail this sheet.

INPUT FILE POSITION LAYOUT

(front view)

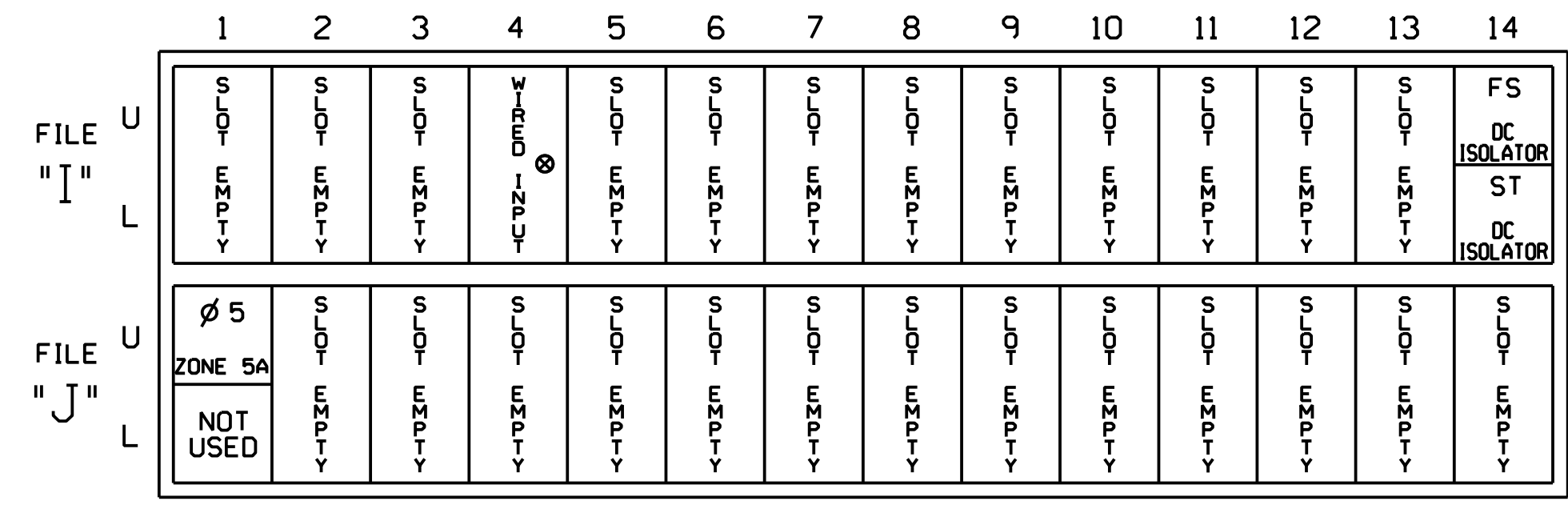

EX.: 1A, 2A, ETC. = LOOP NO.'S
 FS = FLASH SENSE
 ST = STOP TIME
 * Wired Input - Do not populate slot with detector card

INPUT FILE CONNECTION & PROGRAMMING CHART

LOOP NO.	LOOP TERMINAL	INPUT FILE POS.	PIN NO.	INPUT ASSIGNMENT NO.	DETECTOR NO.	NEMA PHASE	CALL	EXTEND	FULL TIME DELAY	STRETCH TIME	DELAY TIME
ZONE 5A	**	J1U	55	17	5	5	Y	Y			15
	-	14U	47	9 *	22	2	Y	Y			
	-	J1U	55	17 *	55	5	Y	Y			

- *Add jumper from J1-W to 14-W, on rear of input file.
- * See vehicle detector setup programming detail for alternate phasing on sheet 3.
- ** Multizone Microwave Detector Zone. See Special Detector Note.

INPUT FILE POSITION LEGEND: J2L

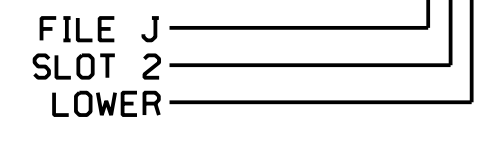

SPECIAL DETECTOR NOTE

Install a microwave detection system for vehicle detection. Perform installation according to manufacturer's directions and NCDOT engineer-approved mounting locations to accomplish the detection schemes shown on the Signal Design Plans.
 For loop 5A, detector card placement and slots reserved for wired inputs are typical for a NCDOT installation. Inputs associated with these slots are compatible with time of day instructions located on sheets 3 and 4 of this electrical detail.

FYA SIGNAL WIRING DETAIL

(wire signal heads as shown)

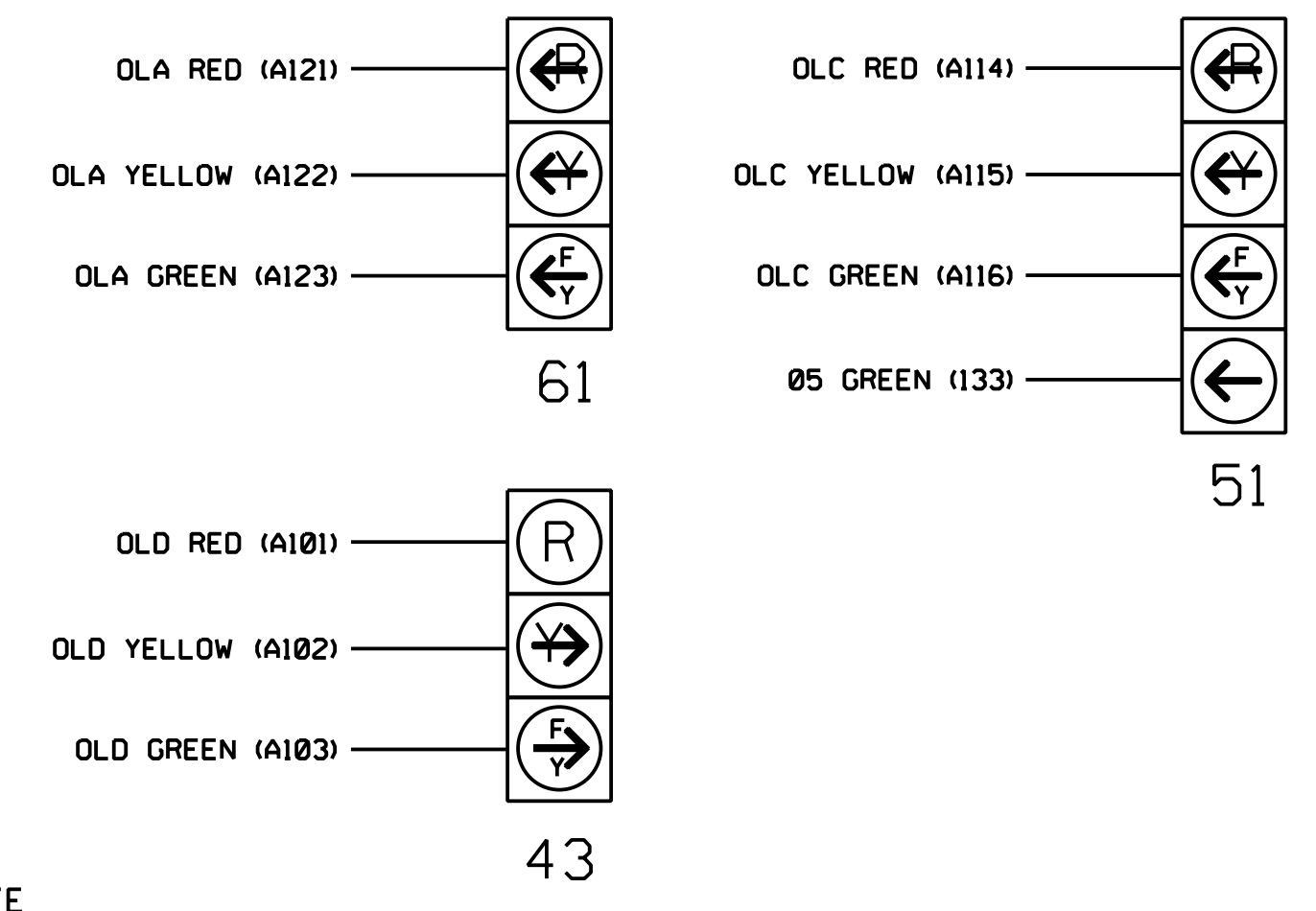

NOTE

The sequence display for signal head 51 requires special logic programming. See sheet 2 for programming instructions.

LOAD RESISTOR INSTALLATION DETAIL

(install resistor as shown)

VALUE (ohms)	WATTAGE
1.5K - 1.9K	25W (min)
2.0K - 3.0K	10W (min)

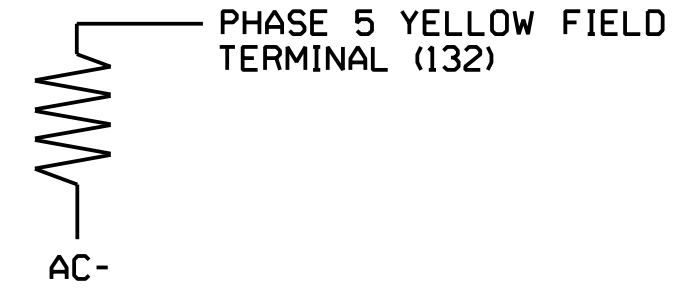

! IMPORTANT: REMOVE RESISTOR FROM PHASE 5 RED FIELD TERMINAL, IF PRESENT.

Electrical Detail - Sheet 1 of 4
 Signal Upgrade
 Temporary Design 4

DOCUMENT NOT CONSIDERED FINAL UNLESS ALL SIGNATURES COMPLETED

 Prepared for: NORTH CAROLINA DEPARTMENT OF TRANSPORTATION Division of Mobility and Safety Design	NC 211 (Southport-Supply Road) at J. Swain Boulevard		SEAL NORTH CAROLINA PROFESSIONAL ENGINEER SEAL 031464 NATASHA R. SIMMONS
	Division 03 Brunswick Co. Southport	PLAN DATE: June 2017 REVIEWED BY: A.D. Klinksiek PREPARED BY: A.H. Thornburg REVIEWED BY: N.R. Simmons	
REVISIONS		INIT. DATE	9/10/2021 SIGNATURE DATE

750 N. Greenfield Pkwy, Corner, NC 27529

HNTB NORTH CAROLINA, P.C.
 343 E. Six Forks Road, Suite 200
 Raleigh, North Carolina 27609
 NC License No: C-1554
 (919) 546-8997

SIG. INVENTORY NO. 03-1043T4