

430

435

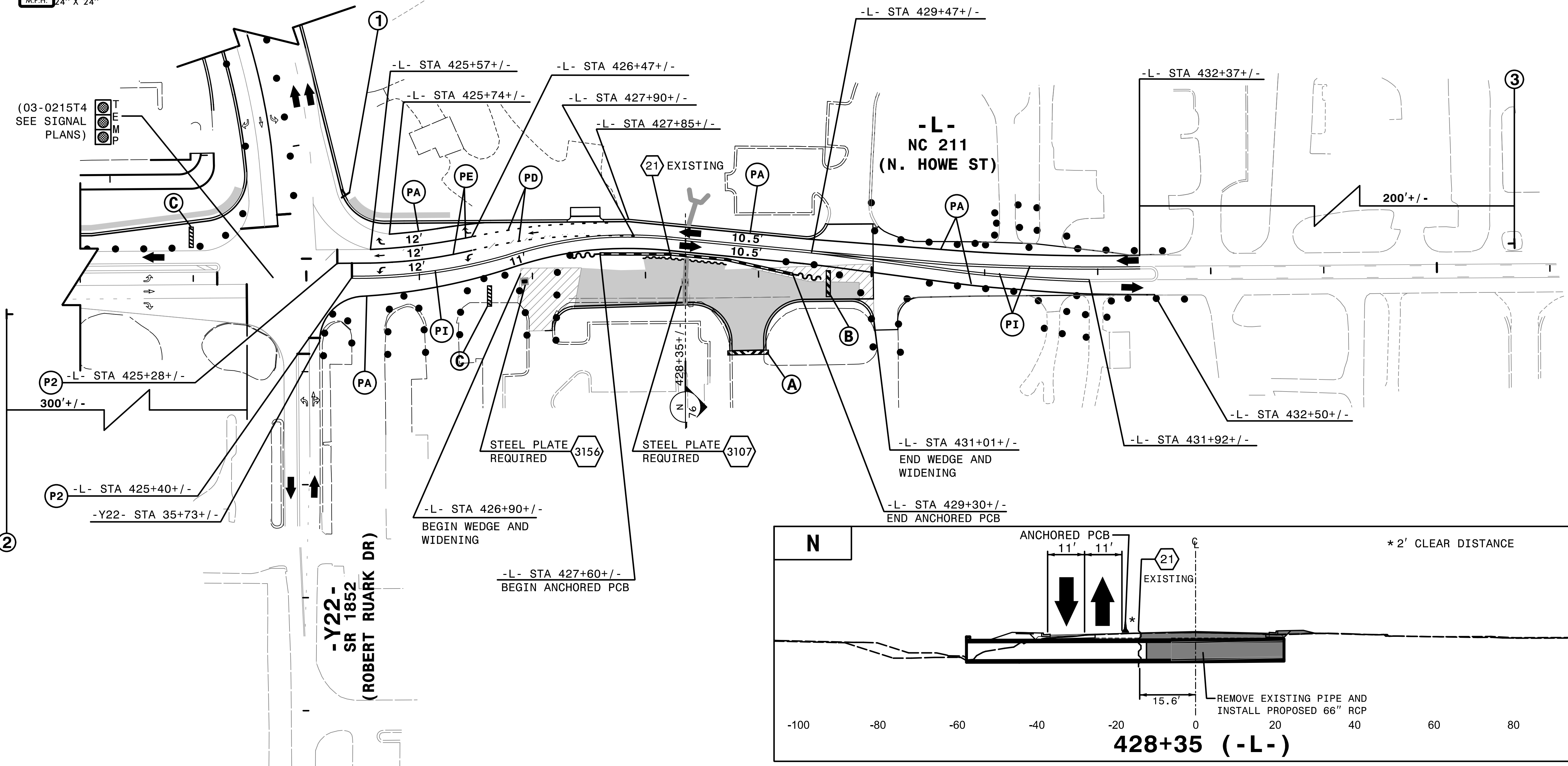

(03-0215T4 SEE SIGNAL PLANS)

P2 -L- STA 425+28+/- 300'+/-

P2 -L- STA 425+40+/-  
-Y22- STA 35+73+/-

-Y22- SR 1852 (ROBERT RUARK DR)

-L- STA 426+90+/-  
BEGIN WEDGE AND WIDENING

-L- STA 427+60+/-  
BEGIN ANCHORED PCB

-L- STA 431+01+/-  
END WEDGE AND WIDENING

-L- STA 429+30+/-  
END ANCHORED PCB

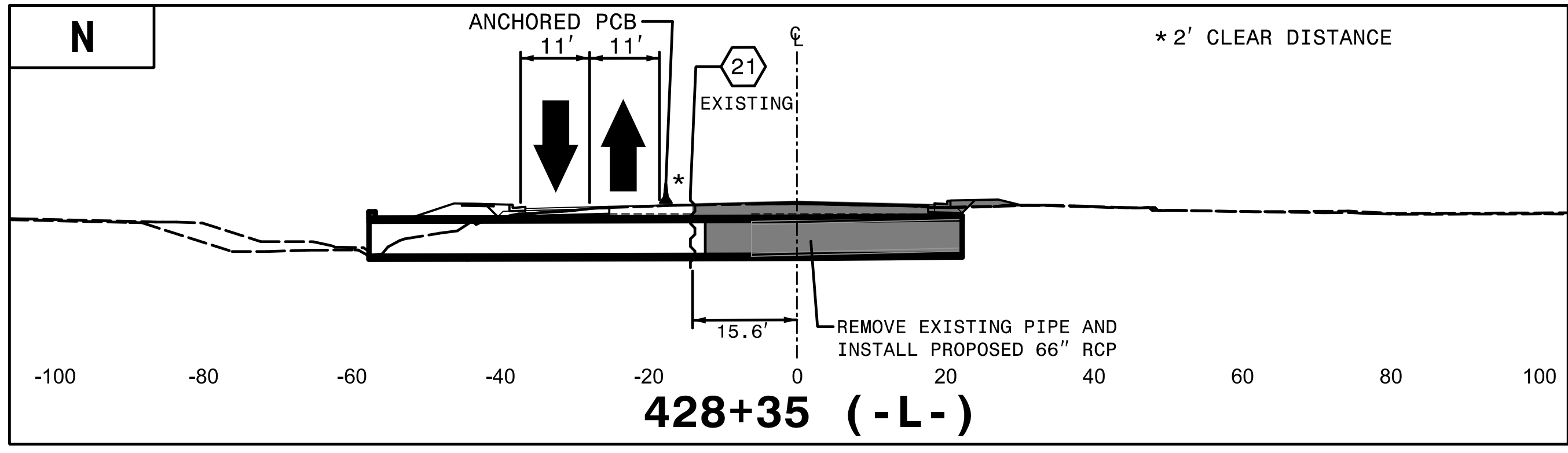

REMOVE CONFLICTING PAVEMENT MARKING.

**HNTB** HNTB NORTH CAROLINA, P.C.  
343 E. Six Forks Road, Suite 200  
Raleigh, North Carolina 27609  
NC License No: C-1554

APPROVED: *Helen Shyu*  
DATE: 11/10/2021  
SEAL  
PROFESSIONAL ENGINEER  
HELEN SHYU  
042517

DIVISION OF HIGHWAYS  
STATE OF NORTH CAROLINA  
DEPARTMENT OF TRANSPORTATION  
WORK ZONE TRAFFIC CONTROL

TRANSPORTATION MANAGEMENT PLAN  
PHASE IB  
STEP 16.4  
DETAIL

4:56:42 PM  
...TCF...502...TC...pid26d.dgn  
...\$\$\$\$USERNAME\$\$\$\$