

6/2/2021

PAVEMENT SCHEDULE (FINAL PAVEMENT DESIGN)	
C1	PROP. APPROX. 1.5" ASPHALT CONCRETE SURFACE COURSE, TYPE S9.5B, AT AN AVERAGE RATE OF 165 LBS. PER SQ. YD.
C2	PROP. APPROX. 3" ASPHALT CONCRETE SURFACE COURSE, TYPE S9.5B, AT AN AVERAGE RATE OF 165 LBS. PER SQ. YD. IN EACH OF TWO LAYERS.
C3	PROP. VAR. DEPTH ASPHALT CONCRETE SURFACE COURSE, TYPE S9.5B, AT AN AVERAGE RATE OF 110 LBS. PER SQ. YD. PER 1" DEPTH. TO BE PLACED IN LAYERS NOT LESS THAN 1" IN DEPTH OR GREATER THAN 1.5" IN DEPTH.
C4	PROP. APPROX. 1.5" ASPHALT CONCRETE SURFACE COURSE, TYPE S9.5C, AT AN AVERAGE RATE OF 168 LBS. PER SQ. YD.
C5	PROP. APPROX. 3" ASPHALT CONCRETE SURFACE COURSE, TYPE S9.5C, AT AN AVERAGE RATE OF 168 LBS. PER SQ. YD. IN EACH OF TWO LAYERS.
C6	PROP. VAR. DEPTH ASPHALT CONCRETE SURFACE COURSE, TYPE S9.5C, AT AN AVERAGE RATE OF 112 LBS. PER SQ. YD. PER 1" DEPTH. TO BE PLACED IN LAYERS NOT LESS THAN 1.5" IN DEPTH OR GREATER THAN 2" IN DEPTH.
D1	PROP. APPROX. 2.5" ASPHALT CONCRETE INTERMEDIATE COURSE, TYPE I19.0C, AT AN AVERAGE RATE OF 285 LBS. PER SQ. YD.
D2	PROP. APPROX. 4" ASPHALT CONCRETE INTERMEDIATE COURSE, TYPE I19.0C, AT AN AVERAGE RATE OF 456 LBS. PER SQ. YD.
D3	PROP. VAR. DEPTH ASPHALT CONCRETE INTERMEDIATE COURSE, TYPE I19.0C, AT AN AVERAGE RATE OF 114 LBS. PER SQ. YD. PER 1" DEPTH. TO BE PLACED IN LAYERS NOT LESS THAN 2.5" IN DEPTH OR GREATER THAN 4" IN DEPTH.
E1	PROP. APPROX. 4" ASPHALT CONCRETE BASE COURSE, TYPE B25.0C, AT AN AVERAGE RATE OF 456 LBS. PER SQ. YD.
E2	PROP. VAR. DEPTH ASPHALT CONCRETE BASE COURSE, TYPE B25.0C, AT AN AVERAGE RATE OF 114 LBS. PER SQ. YD. PER 1" DEPTH. TO BE PLACED IN LAYERS NOT LESS THAN 3" IN DEPTH OR GREATER THAN 5.5" IN DEPTH. (*)NOTE: FOR B25.0C PLACED ON UNSTABILIZED SUBGRADE, MINIMUM LIFT THICKNESS IS 4".
J1	PROP. 6" AGGREGATE BASE COURSE
J2	PROP. 8" AGGREGATE BASE COURSE
J3	VARIABLE DEPTH ABC
K	PROP. 5" CLASS IV AGGREGATE STABILIZATION
P	PRIME COAT, 0.35 GAL/SY
R1	2'-6" CONCRETE CURB AND GUTTER.
R2	2'-9" CONCRETE CURB AND GUTTER.
R3	1'-6" CONCRETE CURB AND GUTTER. (STD MOUNTABLE)
R4	5" MONOLITHIC CONCRETE ISLAND
R5	SHOULDER BERM GUTTER
R6	EXPRESSWAY GUTTER
R7	8"x18" CURB
R8	1'-6" CONCRETE CURB AND GUTTER. (SP 1'PAN-6"GUTTER)
R9	7" JOINTED CONCRETE (WITHOUT DOWELS REINFORCED WITH A W3.5 x W3.5 OR W5 x W5 WIRE MESH)
R10	9"x18" CONCRETE CURB
S1	4" CONCRETE SIDEWALK
T	EARTH MATERIAL
U	EXISTING PAVEMENT
W1	VARIABLE DEPTH ASPHALT PAVEMENT (SEE DETAIL SHOWING METHOD OF WEDGING No. 1)
W2	VARIABLE DEPTH ASPHALT PAVEMENT (SEE DETAIL SHOWING METHOD OF WEDGING No. 2)

NOTE: PAVEMENT EDGE SLOPES ARE 1:1 UNLESS SHOWN OTHERWISE.



PROJECT REFERENCE NO. R-5021	SHEET NO. 2A-1
ROADWAY DESIGN ENGINEER <i>Carl S. Morrison</i> 11/1/2021	PAVEMENT DESIGN ENGINEER <i>Carl S. Morrison</i> 11/2/2021
DOCUMENT NOT CONSIDERED FINAL UNLESS ALL SIGNATURES COMPLETED	

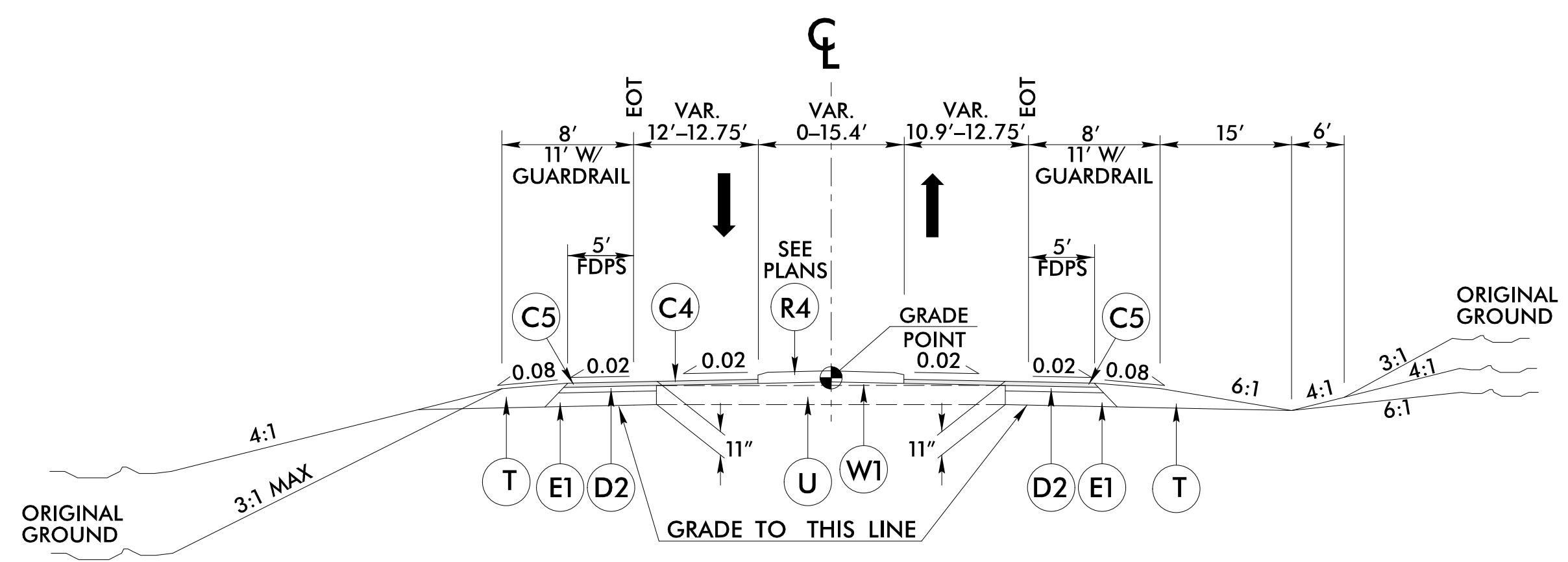
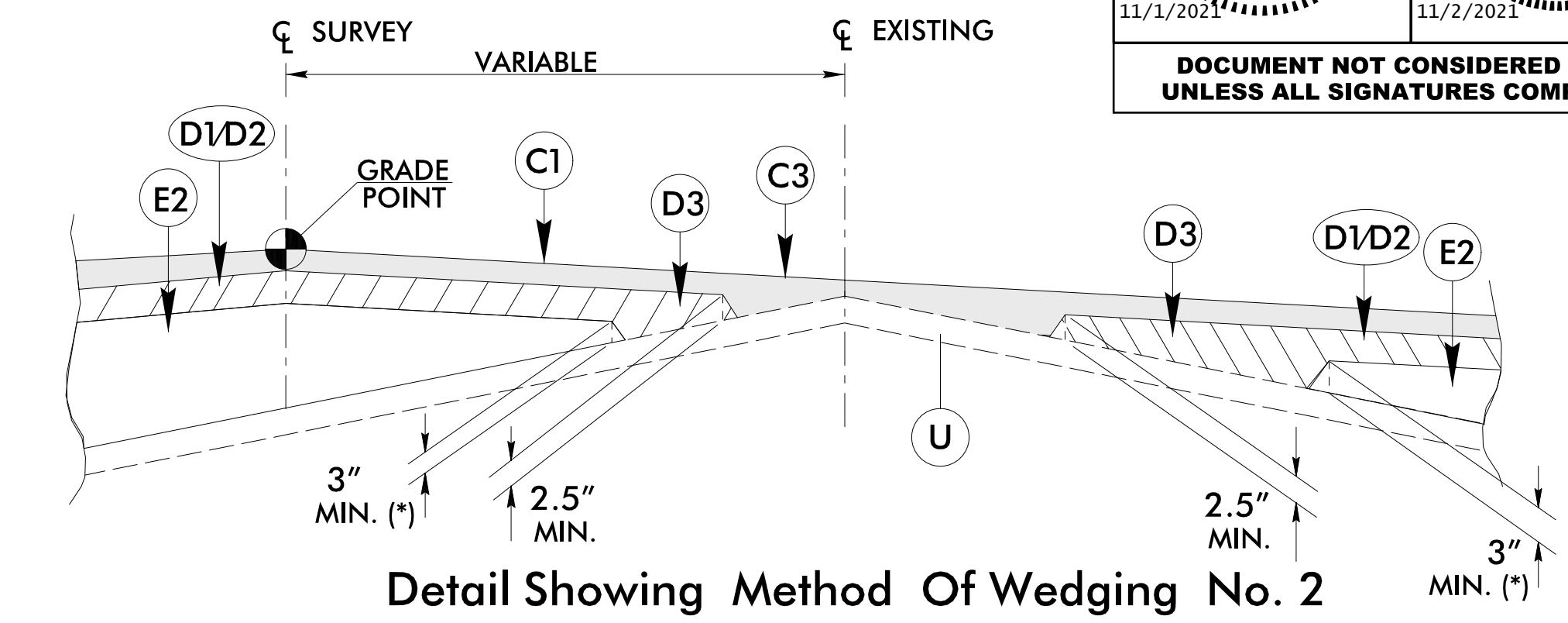
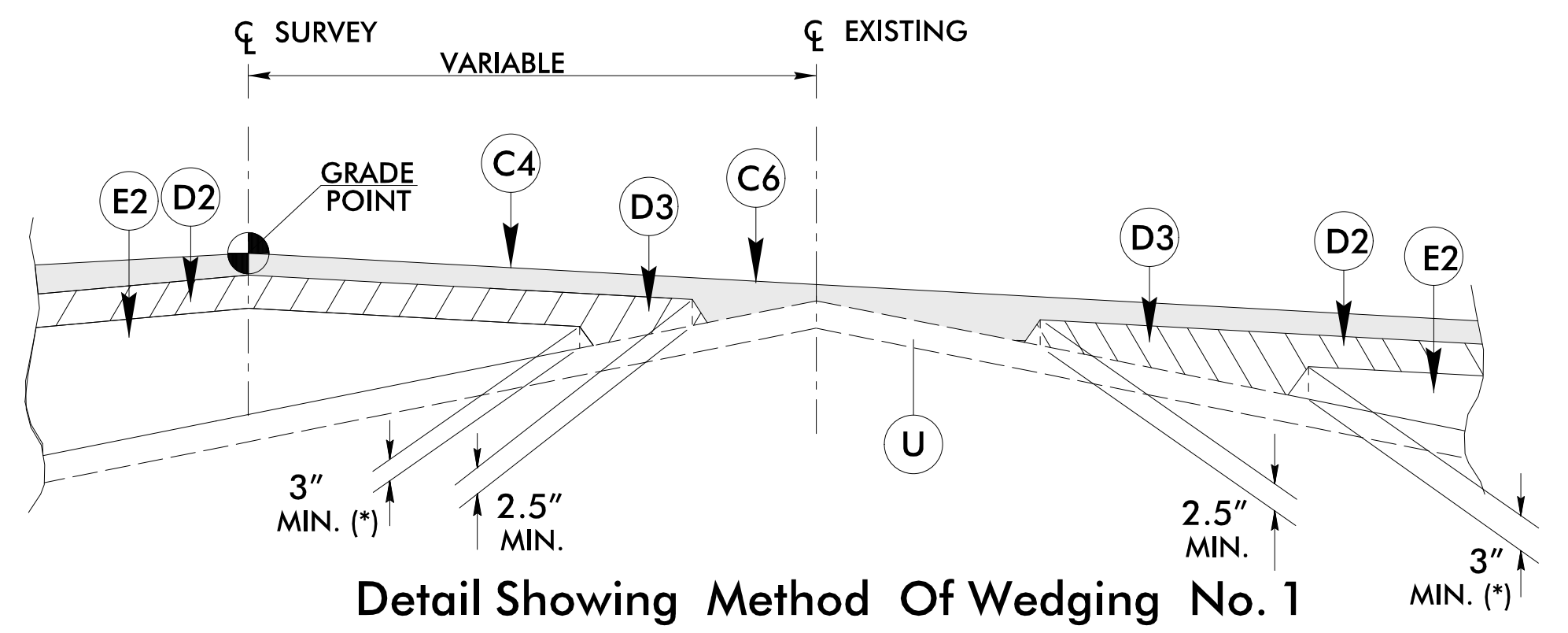

TYPICAL SECTION NO. 1
-L- STA. 47+50.00 TO STA. 53+00.00

TRANSITION TYPICAL SECTION NO. 1 TO TYPICAL SECTION NO. 3
-L- STA. 53+00.00 TO STA. 59+00.00

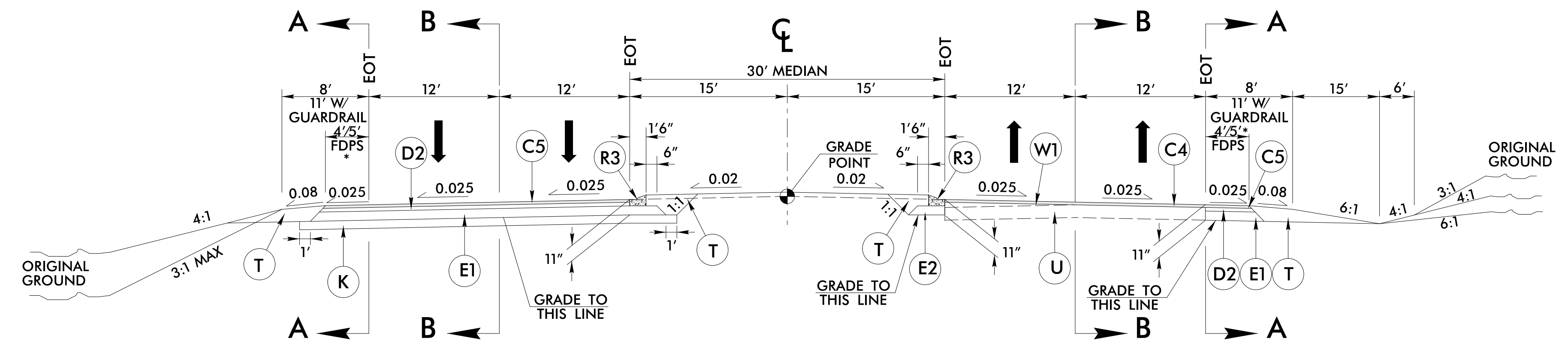

TYPICAL SECTION NO. 2
-L- STA. 53+00.00 TO STA. 54+50.00
-L- STA. 76+00.00 TO STA. 83+05.00
-L- STA. 208+00.00 TO STA. 214+00.00
-L- STA. 229+00.00 TO STA. 243+00.00
-L- STA. 290+00.00 TO STA. 307+10.00
-L- STA. 312+89.00 TO STA. 316+10.00
-L- STA. 317+95.00 TO STA. 368+72.00
-L- STA. 370+12.00 TO STA. 387+76.87
-L- STA. 387+80.00 R 2 TO STA. 388+55.50 R 2
-L- STA. 391+67.00 R 2 TO STA. 425+74.65 R 2

*NOTE: USE 5' FULL DEPTH PAVED SHOULDERS FROM -L- STA 47+50.00 TO STA 300+54.32

NOTE: SEE PLANS FOR SUPERELEVATIONS, TURN LANES, AUXILIARY LANES, MONOLITHIC ISLANDS, CURB & GUTTER, AND LANE TAPER LOCATIONS.

28-SEP-2021 15:49
\\p01adwaj\p-coj\rs021_rdy_typ.dgn
HNTB